

# Satronnic catalogue



**Control boxes for  
oil burners**



**Control boxes for  
gas burner**



**Flame sensors**



**Control boxes for  
special applications  
and accessories**



**Components for  
burners**



**Maintenance and  
teste quipment**

**General items**

## **CONTROL BOXES FOR OIL BURNERS < 30 KG/H**

**TF 801/801.2 TF 802/802.2**

**TF 804/804.2**

**TF 830.3 TF 832.3**

**TF 834.3 TF 836.3**

**TF 840**

**TF 844.3**

**TF 974/976**

**DKO 970/972**

**DKO 974/976 (N)**

## **CONTROL BOXES FOR OIL BURNERS > 30 KG/H**

**TTO 872/876**

**MMO 872/876**

**MMD 900.1**

**TMO 720-4**

**DKW 972/976**

**DMO 976**

## **CONTROL BOXES FOR GAS BURNERS**

**TFI 812**

**MMI 810.1/811.1**

**MMI 812**

**MMI 813.1**

**MMI 815**

**MMI 816**

**MMI 962.1**

**MMG 810.1/811.1**

**TMG 710-3**

**TME 780**

**SGU 930 SGU 930i**

**DKG 972**

**DMG 970**

**DMG 971**

**DMG 972**

**DMG 973**

## **FLAME SENSOR**

**IRD 810/820**

**IRD 1010**

**IRD 1020**

**UVD 970/971**

## **CONTROL BOXES FOR SPECIAL APPLICATIONS AND ACCESSOIRS**

**SOG 960 / SOZ 960**

**MDP 720-1**

**UPR 770**

**FFW 930**

**FR 870/MR 880**

**SFA 970**

## **COMPONENTS FOR BURNERS**

**SOVE 930**

**SOVU 930**

**ZT 8..**

**ZT 870**

**ZT 900**

**ZT 930**

**ZT 931**

# SATRONIC - Control boxes for oil burners

Type	Model	max. firing rate		appr. for direct-air-heaters	action on flame failure		with built in remote reset	with air-damper control	pre-purge	pre-ignition	max. safety time (sec.)	post-ignition (sec.)	delay for 2nd stage	size (box with bas) L x W x H			Possible flame sensors						Notes		
		below 30 kg/h	above 30 kg/h		direct lockout	re-cycle								86 x 60 x 63	86 x 60 x 91	102 x 102 x 120	FZ 711 G / S	MZ 770 S	IRD 810	IRD 910	IRD 911	IRD 1010			
TF 801		x			x				12	12	10	20	-	x			x	x	x						
TF 801 B		x			x				12	12	15	20	-	x			x								version for the UK, 240 V
TF 802.1		x			x				12	12	10	2-4	20	x			x	x	x						
TF 802 B		x			x				12	12	15	2-4	20	x			x								version for the UK, 240 V
TF 804		x			x				12	12	10	3-5	40	x			x		x						for use with oil pre-heater (with override contact)
TF 830.1		x			x				12	12	10	20	-	x			x	x		x	x				
TF 830 B		x			x				12	12	15	20	-	x			x								version for the UK, 240 V
TF 832.1		x			x				12	12	10	2-5	20	x			x	x		x	x				
TF 832 B		x			x				12	12	15	2-5	20	x			x								version for the UK, 240 V
TF 834.1		x			x				12	12	10	20	-	x			x	x		x	x				for use with oil pre-heater (with override contact)
TF 834 E.1		x			x				12	12	10	-	-	x			x			x	x				for use with oil pre-heater (with override contact)
TF 834.2		x			x				12	12	10	20	-	x			x	x		x	x				low-voltage protected according EN 230
TF 836		x			x				12	12	10	2-4	20	x			x			x	x				for use with oil pre-heater (with override contact)
TF 840		x			x				12	12	10	25	3-5	x			x			x	x				
TF 844		x			x				12	12	10	3-5	3-5	x			x			x	x				for use with oil pre-heater (with override contact)
MMD 900					x	x			15	2	5	15.5	17.5									x	x		for SATRONAIR burner components only
MMD 900.1					x	x			15	15	5	20	52												for mainly blue-burning flames
TTO 872.2			x	x		x			20	20	5	2-4	40	x			x					x	x		
TTO 876.2			x	x		x			20	20	5	2-4	40	x			x					x	x		for use with oil pre-heater (with override contact)
MMO 872			x	x	x				24	24	5	8	40				x					x	x		
MMO 876			x	x	x				24	24	5	8	40				x					x	x		for use with oil pre-heater (with override contact)
TMO 720 - 4	15		x	x	x	x	x	x	10	30	5/1	8	12			x	x			x					x
TMO 720 - 4	15 OE		x	x	x	x	x	x	10	10	5/1	8	12			x	x			x					x
TMO 720 - 4	35		x	x	x	x	x	x	30	30/2	5/1	8	12			x	x			x					x







# Approvals

## Control boxes for oil burners

○ currently under test    approved    Δ certified

Country		EU	D					CH	GB	NL	A	F	I
Type	Model	EC-P.I.N.	DIN Rg. Nr.	valid until...	DVGW Nr.	valid until...	appr.for DAH						
TF 801			12842/90	11/95									
TF 801.2			5F071/95	02/00									
TF 801 B									Δ				
TF 802 B									Δ				
TF 802.1			12773/90	11/94									
TF 802.2			5F072/95	02/00									
TF 804			12762/89	09/94									
TF 804.2			5F073/95	02/00									
TF 821													
TF 822													
TF 830 B									Δ				
TF 830.1			12774/90	11/94									
TF 830.2			5F074/95	04/04									
TF 830.3			5F176/99	02/00									
TF 832 B									Δ				
TF 832.1			12775/90	11/94									
TF 832.2			5F075/95	02/00									
TF 832.3			5F177/99	04/04									
TF 834.1			12776/90	11/94									
TF 834.2			5F037/93	07/98									
TF 834.3			5F178/99	04/04									
TF 834 E.1			12788/90	10/95									
TF 834 E.2			5F076/95	02/00									
TF 834 E.3			5F179/99	04/04									
TF 836.1			12830/89	07/94									
TF 836.2			5F077/95	02/00									
TF 836.3			5F180/99	04/04									
TF 840			12778/90	11/94									
TF 844			12779/90	11/94									
TF 844.2			5F078/95	02/00									
TF 844.3			5F181/99	04/04									
TF 974			5F148/98	01/03									
TF 974 E			5F162/98	12/03									
TF 976			5F149/98	01/03									
DKO 970			5F140/97	11/02									
DKO 972			5F141/97	11/02									
DKO 974			5F142/97	11/02									
DKO 974 N			5F143/97	11/02									
DKO 976			5F144/97	11/02									
DKO 976 N			5F145/97	11/02									
TTO 836	35		12843/91W	01/96			x						
TTO 872.2			5F031/93	06/98			x						
TTO 876.2			5F030/93	06/98			x						
MMO 872			5F062/94	09/99			x						
MMO 876			5F063/94	09/99			x						
DKW 972			5F146/97	11/02			x						
DKW 976			5F147/97	11/02			x						
DMO 976			5F163/98	12/03			x						
MMD 880			12834/89W	11/94									
MMD 900			12856/915	09/96			x						
MMD 900.1			5F022/93	04/98			x						





# Control boxes for gas burners

○ currently under test    approved    Δ certified

Country		EU	D					CH	GB	NL	A	F	I
Type	Model	EC-P.I.N.	DIN Rg. Nr.	valid until...	DVGW Nr.	valid until...	appr.for DAH						
TMMG 810	43	63AO6850											
MMG 810.1	43	63AO6850											
MMG 810	45	C87AP1											
MMG 810.1	45	63AO6850											
MMG 810	63	63AO6850											
MMG 810	65	63AO6850											
MMG 811	33	63AO6850			89.01 f SR	04/94							
MMG 811.1	33	63AO6850											
MMG 811	63	63AO6850											
MMG 811.1	63	63AO6850											
MMG 816		63AO6850											
MMG 870.1	65	63AO6850											
TMG 740-2	32-32				94.02 f SR	07/99	x				53BE	11/90	
TMG 740-2 F	32-32										52 B		
TMG 740-2	63-55									Δ			
TMG 740-2	63-58									Δ			
TMG 740-2	45-54										85BE		
TMG 740-3	12-22		12872/92S	01/97	92.04 f SR	02/97							
TMG 740-3	32-32	63AO6850	12871/92W	02/97	92.03 f SR	02/97							
TMG 740-3	43-35	63AO6850											
TMG 740-3 110V	43-35	63AO6850											
TMG 740-3	63-55	63AO6850											
TMG 740-3	63-58	63AO6850											
TMG 740-3	13-53	63AO6850	5F092/95	08/00	96.01 f SR	01/01							
DKG 972		85AT0365			98-0872-GEE								
DMG 970		85AT0367			98-0872-GEE								
DMG 971		85AT0367			98-0872-GEE								
DMG 972		85AT0367			98-0872-GEE								
DMG 973		85AT0367			98-0872-GEE								
SGU 930	33-33	0085AP0838	5F064/94	10/99									
SGU 930 110V	33-33	0085AP0838	5F064/94	10/99									
SGU 930i	33-33	0085AP0839	5F065/94	10/99									
SGU 930i 110V	33-33	0085AP0839	5F065/94	10/99									
TMA 740-1	10-58												
TME 780	32-52	0063AR1447	5F049/99	01/04	94.01 f SR	01/99							
IRD 820					Δ								
IRD 920					Δ								
IRD 1020					Δ								
UVD 971													
ZT 870								Δ					
ZT 812								Δ					

## Approvals



Satronic AG  
Brüelstrasse 7  
Postfach 324  
CH-8157 Dielsdorf

**EG-Baumusterkonformitätserklärung**  
**EU type conformity certificate**  
**Déclaration CE de conformité au type**  
**Dichiarazione di conformità CE**

**Satronic AG** bescheinigt hiermit, dass die in dieser Übersicht genannten Produkte aufgrund der vorliegenden **EG-Baumusterprüfbescheinigungen** die grundsätzlichen Anforderungen der **Gasgeräte-Richtlinie 90/396/EWG** in der gültigen Fassung erfüllen.

Die Anforderungen der weiteren, zutreffenden Richtlinien bezüglich **EMV-Richtlinie 89/336/EWG** **Niederspannungs-Richtlinie 73/23/EWG** werden ebenfalls erfüllt.

Grundlage der EG-Baumusterprüfungen sind die harmonisierten Normen und DIN-Normen.

**Geltungsbereich der EG-Baumusterkonformitätserklärung**  
Alle CEN-Mitgliedsländer.  
(Comité Européen de Normalisation)

**CE-Zeichen/CE-Nummer**  
Die **Satronic** Produkte tragen auf dem Typenschild ihre EC-Product Identification No.  
Die Geräte haben **kein CE-Zeichen**, da es sich nicht um direkt gebrauchsfertige Gasgeräte handelt (Gasgeräte-richtlinie 90/396/EWG Artikel 8).

**Satronic AG** certify by the present **EU type certificates** that the products specified in this list meet the basic requirements of the **Gas Equipment Directive 90/396/EEC** in its prevailing version.

The requirements of other relevant directives concerning **EMC-Directive 89/336/EEC** **Low-voltage-Directive 73/23/EEC** are also fulfilled.

The EU type certificates are based on the European standards and DIN standards.

**Scope of the EU type conformity certificate**  
All member states of the CEN.  
(Comité Européen de Normalisation)

**CE-symbol/CE-number**  
The EC-Product Identification No. of **Satronic** products are printed on their type label.  
The equipment **has no CE-symbol** since it does not constitute ready-to-use gas equipment (gas equipment directive 90/396/EEC Article 8).

La Société **Satronic AG** attestent par la présente que les produits mentionnés dans ce document répondent aux **certificats d'examen CE** de Type conformément aux exigences fondamentales de la **Directive européenne concernant les appareils à gaz 90/396/CEE**.

Les exigences des autres dispositions en vigueur relatives à la **Directive CEM 89/336/CEE** **Directive Basse Tension 73/23/CEE** sont également remplies.

L'harmonisation des normes ainsi que les normes DIN sont à la base des certificats d'examen CE de type.

**Validité de la déclaration CE de conformité au type**  
Tous les états membres de la CEN.  
(Comité Européen de Normalisation)

**Marque-CE/Numéro-CE**  
Les produits **Satronic** portent leur No. d'identification produit CE sur la plaque signalétique.  
Les appareils **n'ont pas de marque-CE**, en effet, il ne s'agit pas directement d'appareils à gaz prêts à être utilisés (Disposition en matière d'appareils à gaz 90/396/CEE Article 8).

La **Satronic AG** dichiarano che i prodotti menzionati in questa lista, in base ai presenti **certificati di collaudo CE** soddisfano le esigenze fondamentali della **Direttiva CE valida per apparecchiature per gas 90/396/CEE**.

Le esigenze poste dalle ulteriori direttive in riferimento alla **Direttiva 89/336/CEE** **concernente le apparecchiature a bassa tensione 73/23/CEE** vengono pure soddisfatte.

Alla base dei collaudi dei tipi, sono le norme armonizzate e le norme DIN.

**Limiti di validità della dichiarazione di conformità CE per campioni d'utilità sono**  
tutti i paesi membri della CEN.  
(Comitato Europeo di Normalizzazione)

**Sigla-CE/Numero-CE**  
I prodotti **Satronic** portano sulla targhetta il numero d'identificazione CE. Alcune apparecchiature **non possiedono la sigla-CE**, poiché si tratta di apparecchi per gas non direttamente utilizzabili (direttiva per apparecchiature per gas 90/396/CEE articolo 8).

**Artikel**  
**Article designation**  
**Désignation de l'article**  
**Denominazione**

**CE-Nummer**  
**CE-Number**  
**Numéro CE**  
**CE-Numero**

TFI 812.2	5	63AO6850
TFI 812.2	10	63AO6850
TFI 812.2 E	10	63AO6850
TFI 812.2 B	5	63AO6850
TFI 812.2 B	10	63AO6850
TFI 812.3	5	63AO6850
TFI 812.3	10	63AO6850
TFI 812.3 B	5	63AO6850
TFI 812.3 B	10	63AO6850

SKG 960	520	63AS1588
SCM 970		63AS1588

MMI 810	33	C87AP1
MMI 810	35	63AO6850*
MMI 810	40-34	C87AP1
MMI 810	43	63AO6850*
MMI 810	45	C87AP1
MMI 810	55	63AO6850*
MMI 810	63	63AO6850*
MMI 810	65	63AO6850*
MMI 810.1	45	63AO6850*
MMI 811	35	63AO6850
MMI 811	63	63AO6850
MMI 812	33	63AO6850*
MMI 812.1	23	63AO6850*
MMI 813	23	63AO6850*
MMI 815	5	63AO6850
MMI 815	10	63AO6850

MMG 810	33	C87AP1
MMG 810	43	63AO6850*
MMG 810	45	C87AP1
MMG 810	63	63AO6850*
MMG 810	65	63AO6850*
MMG 810.1	45	63AO6850*
MMG 811	33	63AO6850
MMG 811	63	63AO6850
MMG 816		63AO6850

TMG 740-3	32-32	63AO6850
TMG 740-3	43-35	63AO6850*
TMG 740-3	43-35 110V	63AO6850*
TMG 740-3	63-55	63AO6850
TMG 740-3	63-58	63AO6850
TMG 740-3	13-53	63AO6850

TME 780	32-52	0063AR1447
---------	-------	------------

SGU 930	33-33	0085AP0838
SGU 930i	33-33	0085AP0839
SGU 930	33-33 110V	0085AP0838
SGU 930i	33-33 110V	0085AP0839

**Artikel**  
**Article designation**  
**Désignation de l'article**  
**Denominazione**

**CE-Nummer**  
**CE-Number**  
**Numéro CE**  
**CE-Numero**

○ = zur Prüfung eingereicht  
○ = presented for test purposes  
○ = déposé pour homologation  
○ = inviato per collaudo

\* = zugesagte CE-Nummer  
\* = applicable CE-Number  
\* = Numéro CE enregistré  
\* = CE-Numero riservato

**CE-Zulassungen**









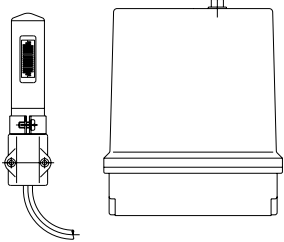
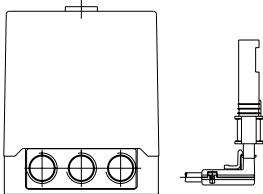
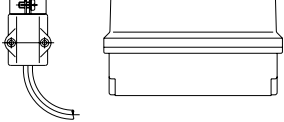
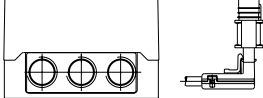
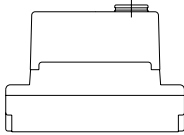
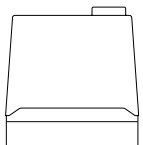
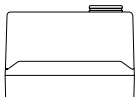
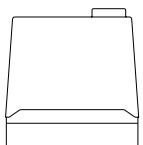
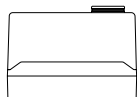
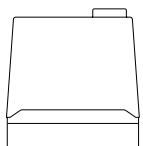
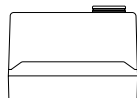
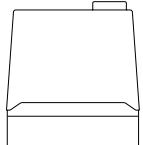
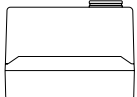
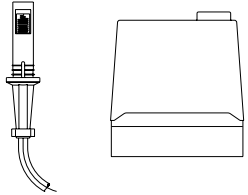
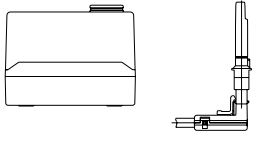

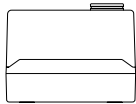
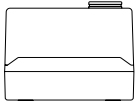
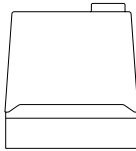
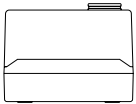
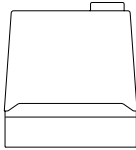
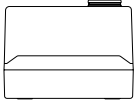
A Honeywell Company

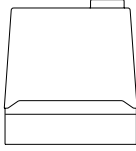
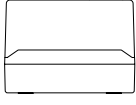
Satronic AG  
Brüelstrasse 7  
Postfach 324  
CH-8157 Dielsdorf

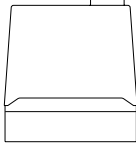
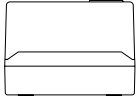
**for oilburners**

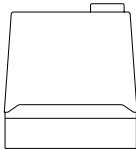
OLD TYPE	REPLACED	→	BY	POSSIBLE NEW TYPE
IBR 661 + FZ 612				TME 780 + FZE 780
OBR 661 + FZ 612 BR 661 + FZ 612				TMO 720-4 + FZ 711 5)
KBR 611 KBR 612 KBR 612 A / TF 21 A KBR 614 A / TF 20 KBR 617 A / TF 22 KBR 617 C				TF 701-1 + US 7900 * )**) or TF 801 + US 7900 1) or TF 802 + US 7900 1)
TF 701, TF 701-1				TF 801 (1-stage) 1) or TF 802 (2-stage) 1)
TF 701 B				TF 801 B (1-stage) 1) or TF 802 B (2-stage) 1)
TF 704 (without override contact)				TF 804 1) (with override contact)
TF 714-1				TF 802 1)
TF 721 + FZ 711				TF 821 (1-stage) + 1)2) MZ 770 or TF 822 (2-stage) + MZ 770 TF 830 TF 832

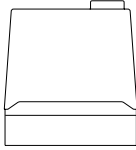
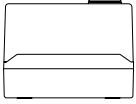
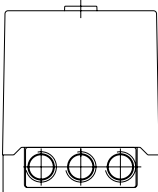
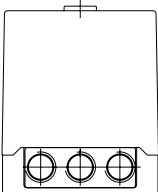
OLD TYPE	REPLACED	→	BY	POSSIBLE NEW TYPE	
TF 821 TF 822				TF 830 TF 832	6)
TF 730-1 TF 730-2				TF 830 (1-stage) or TF 832 (2-stage)	1) 1)
TF 734				TF 834	1)
TF 734-2 + GZ 770				TF 834E + MZ 770	1)2)
TF 740 + FZ 711				TF 840 + MZ 770	1)2)
TTO 750-1 + FZ 711 TTO 810 + FZ 711				TTO 872 + MZ 770	1)2)4)
TTO 836				TTO 876	1)
TMO 720 TMO 720-2 TMO 721				TMO 720-4	

#### ATTENTION

\*) no longer available.

\*\*) please note leaflet US 7900.

1) to compensate the height of TF 700/800, the reset button extension can be used, Art. Nr. 70601.

2) the different diameter of the photocells can be compensated by an adapter or by using the MZ-mounting flange.

3) remove link live-terminal 1.

4) verify that terminal 1 is not connected to live.

5) new wiring incl. new base necessary.

6) also approved in Hungary since 1992.

## Cross reference list

**satronic**

A Honeywell Company

Satronic AG  
Brüelstrasse 7  
Postfach 324  
CH-8157 Dielsdorf

## for gas- and dual-fuel burners

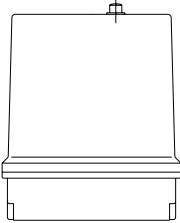
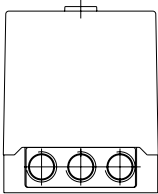
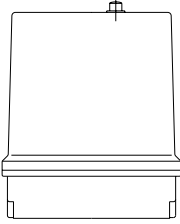
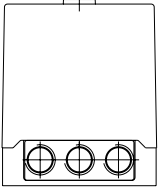
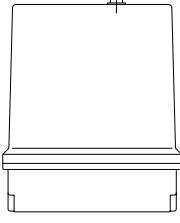
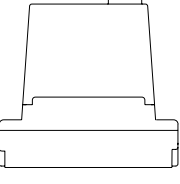
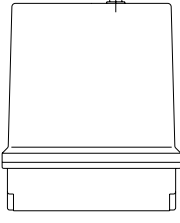
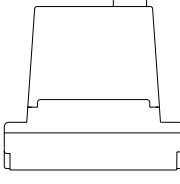
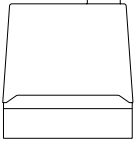
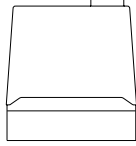
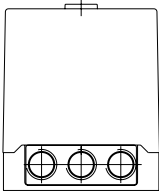
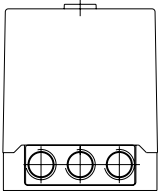
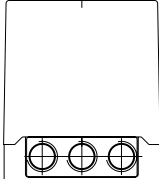
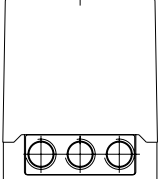
OLD TYPE	REPLACED	→	BY	POSSIBLE NEW TYPE	
IBR 661 + UVF 662 + UVZ 716 IBR 661 + IFW 661				TME 780 + UVZE TME 780	5) 5)
BR 661 + UVF 661 + UVZ 716 BR 661 + IFW				TMG 740-3 + UVZ 780 TMG 740-3	5) 5)
GBR 681				MMI 810	**)
GBR 681/74				MMI 810	**)
TTI 790				MMI 810	2)3)
TMG 720 TMG 740 TMG 740-1				TMG 740-2	
TMG 740-2				TMG 740-3	4)

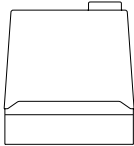
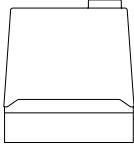
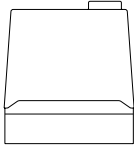
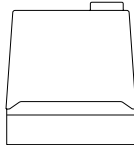
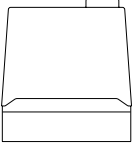
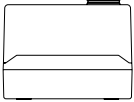
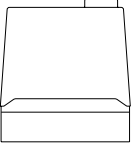
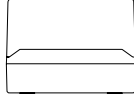
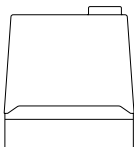
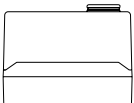
OLD TYPE	REPLACED	→	BY	POSSIBLE NEW TYPE
TTG 760				MMG 810
TTG 760 FN				for France: TTG 760 FN *) other countries: MMG 811
TFI 712F-1 TFI 712F				TFI 812 Mod. 5 1)
TFI 712-1 TFI 712				TFI 812 Mod. 10 1)
TFI 735-1 TFI 735				TFI 812 B 1)

**ATTENTION**

\*) no longer available.

\*\*) please note leaflet US 7910.

1) to compensate the height of TF 700/800,  
the reset button extension can be used, Art. Nr. 70601.

2) link between terminals 1 and 9 mandatory.

3) fail-safe air pressure switch supervision.

4) check the correct UV / Ion switch setting.

5) new wiring incl. new base necessary.

**Cross  
reference list**

## Oil Burner Safety Control

**For 1- or 2-stage oil power burners up to 30kg/h capacity and intermittent operations.**

### Flame detection:

- Photoresistor FZ 771 S
- Infrared-flicker detector IRD 1010
- UV solid state sensor UVD 970

### APPLICATION RANGE

The TF 801 or TF 802 oil burner safety control boxes are suitable to control and monitor oil power burner up to 30 kg/h capacity (approved and certified according to DIN 4787). The control boxes TF 801.2 and TF 802.2 are approved and certified according to EN230.

### TYPES AVAILABLE

TF 801	1-stage operation post-ignition time ca. 20 sec.
TF 801.2	1-stage operation post-ignition time ca. 20 sec. low voltage protection according to EN230
TF 802	2-stage operation post-ignition time 2-4 sec.
TF 802.2	2-stage operation post-ignition time 2-4 sec. low voltage protection according to EN230

### CONSTRUCTIONAL FEATURES

The control box circuitry is protected by a flame resistant, transparent plastic housing. It incorporates the thermo-mechanical, temperature compensated timer, flame check and reset circuits.

Manual reset from lockout is provided by a push button with an integrated lockout signal lamp. A central fixing screw locks the control box to the wiring base. The wiring base and control box have a positive plug-in arrangement, making it impossible to achieve an incorrect connection between the two parts. A variety of cable entry points provides utmost flexibility of electrical wiring.



The TF 802.2 is fully compatible with the TF 701, 701-1 and TF 802. The flame detector IRD 910 must be replaced by its compatible type IRD 1010. An optional extension button (item no. 70601) compensates for height differences.



### TECHNICAL DATA

Operating voltage	220/240V (-15..+10%) 50 Hz (40-60Hz)
Fuse rating	10 A fast, 6 A slow
Power consumption	ca. 5 VA
Max. load per output	
- terminal 3	1.5 A, cos φ 0.2
- terminal 4	4 A, cos φ 0.4
- terminal 5	0.5 A, cos φ 0.4
- terminal 6	0.5 A, cos φ 0.4
- terminal 7	0.1 A, cos φ 0.4
total load	5A, cos φ 0.4
Pre-purge time	ca. 12 sec.
Pre-ignition time	ca. 12 sec.
Post-ignition time	TF 801/TF801.2 ca. 20 sec. TF 802/TF802.2 ca. 2-4 sec
Delay time to oil valve 2	40 sec. (TF 802)
Lockout safety time	10 sec.
Reset time from lockout	ca. 90 sec
Flame detector:	
FZ 771 S red	side-on viewing
FZ 771 S white	side-on and end-on viewing
Light sensitivity FZ 711S	> 10 Lux
IRD 1010	side-on or end-on viewing
UVD 970	end-on viewing
Weight incl. wiring base	0.25 kg
Mounting position	any
Protection class	IP44
Recommended ambient operating temperature for control and flame detector	0°C...+60°C
approved and certified according to European standards	
TF 801.2/TF802.2	EN 230
TF 801/TF802	DIN 4787

## APPLICATION NOTES

### 1. Flame control

The following detectors can be used for flame control:

- For yellow oil flame: photoresistor FZ 771 S (red inscription: side-on; white inscription: side-on and end-on viewing)
- for blue or yellow flame: infrared-flicker detector type IRD 1010 or as alternative the UV solid state sensor UVD 970.

Using the photo resistor FZ 711 S, the no flame signal is generated at light levels below 3 Lux with respect to the operating cycle of the control. According to DIN74787 and EN 230 stray light safety level has to be established in conjunction with the accompanying burner.

Connecting the IRD 1010 or the UVD 970, the correct wiring has to be observed.

### 2. Burner control

For burners without an oil solenoid valve, the burner motor has to be connected to terminal 5.

### 3. Low-voltage protection

TF 801.2 and TF 802.2 only

- The mains voltage has to be more than  $187 V_{\text{eff}}$  in order to allow the unit to perform a start-up.
- The mains voltage is not only monitored in the start-up phase but also permanently during operation. If the voltage drops below  $<160 V_{\text{eff}}$  during start-up or run time the control box goes into lockout mode. If the voltage rises again, the control box performs automatically a start-up as soon as the mains voltage is  $>187 V_{\text{eff}}$ .

### 4. Safety

The design and control sequence of the TF 801/TF 801.2 and TF 802/TF802.2 control boxes comply with the currently applicable European standards and regulations.

### 6. Mounting and electrical wiring

Wiring base:

- 3 earth terminals with additional terminal for burner earthing
- 3 neutral terminals with internal permanent connection to neutral terminal (terminal 7)
- 2 spare auxiliary terminals
- 2 slide in plates and 2 easy-knockout holes (PG 11 thread), plus 2 easy-knockout holes in the bottom of the base facilitate the wiring.
- The 3-wire sensor cable can be used for the IRD and UVD as well as for the FZ711 S. Please keep that in mind for burners which may be upgraded from FZ to IRD or UVD later on (e.g upgraded to a blue flame burner).

General:

- The control box can be mounted in any position. The protection class is IP44 (water spray tight). Neither the control box nor the flame detector should be subjected to excessive vibration.

## COMMISSIONING AND ROUTINE CHECKS

### 1. Important notes

- The controls must be installed by qualified personnel only. The relevant national regulations have to be observed.
- On commissioning the wiring has to be carefully checked according the appropriate diagram, Incorrect wiring can damage the unit and endanger the installation.
- The fuse rating has to ensure that the limits specified in TECHNICAL DATA will not be exceeded. If these precautions are not observed, the effect of a short circuit can cause severe damage to the control and installation.
- For safety reasons a minimum of one control shut-down per 24 hours has to be observed.
- Disconnect the mains before the control box is plugged in or out!
- The control box is a safety device and must not be opened!

### 2. Function control

For safety reasons the flame detection system should be tested on commissioning the installation as well as after a service or longer shut-down.

Prerequisite: mains voltage  $>187 V_{\text{eff}}$   
(for TF801.2 and TF 802.2 only)

- a) Start-up with covered flame detector
  - After lock-out safety time is over the unit has to go into lockout mode!
- b) Start-up with exposed flame detector:
  - After 20 sec. pre-purge time the unit has to go into lockout mode!
- c) Normal start-up with burner in the normal position, cover up the flame detector:
  - After start-up, and end of lock-out safety time the unit has to go into lockout mode!
- d) The flame sensor signals can be checked either using the UP 940 or performing the following measurements:
  - For TF801 and TF802 only: The measured sensor signal during operation should be minimal 2.4mA
  - For TF801.2 and TF802.2 only: The sensor signal measurements are not reliable, as only marginal values changes occur. Measure instead the voltage across the photo resistor! For a reliable flame monitoring the DC voltage across the photo resistor (terminal 1 and 2) in operating mode should be less than 2 V.

### 3. Fault findings

Burner is not working:

- thermostat circuit open
- faulty electrical wiring
- mains voltage  $<187 V_{\text{eff}}$  (for TF801.2 and TF 802.2 only)

Burner starts, but the flame does not establish, a lock out occurs:

- stray light on flame detector
- no ignition or no fuel

Burner starts, the flame establishes, but after the safety time, a lock out occurs:

- dirty or faulty flame detector
- insufficient light on detector
- sensitivity adjustment too low on IRD.

For a quick and safe diagnosis use the Satronic UP 940 burner test box.

### CIRCUIT AND TIMING DIAGRAM TF 801/TF 801.2

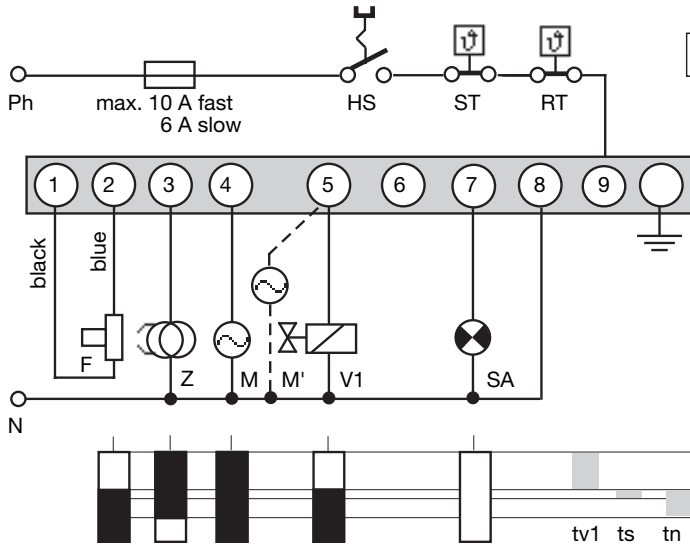

### IRD-OR UVD CONNECTION

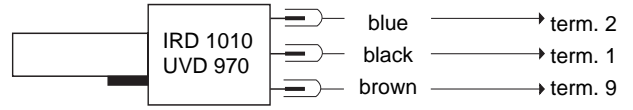

- HS Mains switch
- ST Limit thermostat
- RT Control thermostat
- F Flame detector FZ 711 S (IRD 1010, UVD 970 see separate diagram)
- Z Ignition
- M Burner motor (burner **with** solenoid valve)
- M' Burner motor (burner **without** solenoid valve)
- V1 Oil solenoid valve, 1st-stage
- SA External lock-out signal
- tv1 Pre-ignition time with or without pre-purge
- ts Lock-out safety time
- tn Post-ignition time

### CIRCUIT AND TIMING DIAGRAM TF 802/TF 802.2

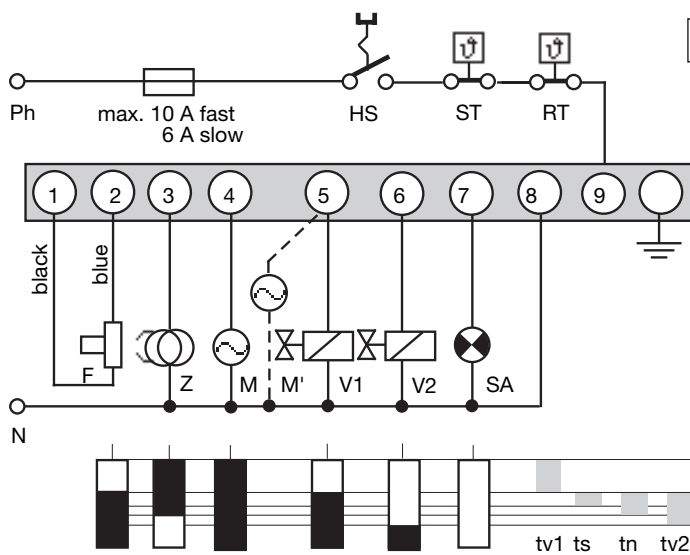

### IRD-OR UVD CONNECTION

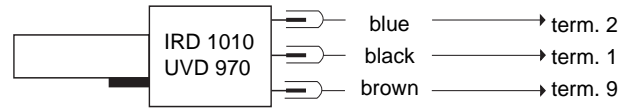

- HS Mains switch
- ST Limit thermostat
- RT Control thermostat
- F Flame detector FZ 711 S (IRD 1010, UVD 970 see separate diagram)
- Z Ignition
- M Burner motor (burner **with** solenoid valve)
- M' Burner motor (burner **without** solenoid valve)
- V1 Oil solenoid valve, 1st-stage
- V2 Oil solenoid valve, 2nd stage
- SA External lock-out signal
- tv1 Pre-ignition time with or without pre-purge
- ts Lock-out safety time
- tn Post-ignition time
- tv2 Delay 2nd stage

### SCHEMATIC DIAGRAM TF 801.2

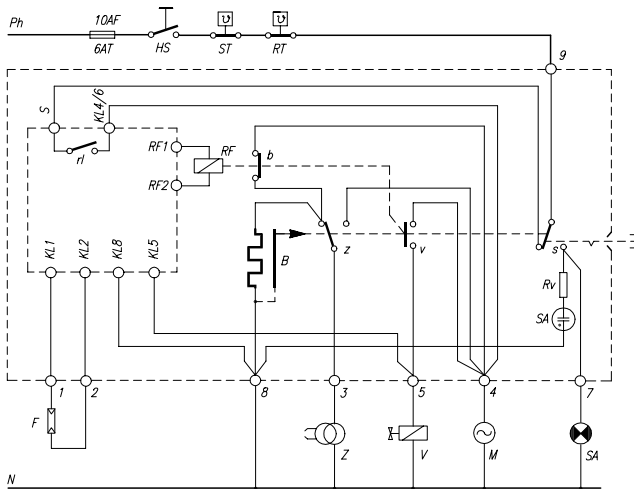

### SCHEMATIC DIAGRAM TF 802.2

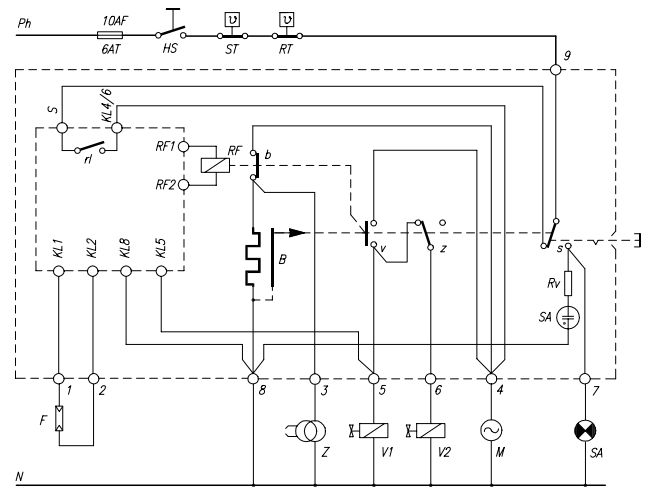

- HS Mains switch
- ST Limit thermostat
- RT Control thermostat
- SA Lock-out signal indicator
- F Flame detector MZ 770 S, IRD 1010 or UVD 970
- V Valves
- Z Ignition
- M Burner motor

- RF Flame relay
- r1 low voltage relay
- B Thermomechanical timer
- RV Resistor

### TF 80X AND SOCKET

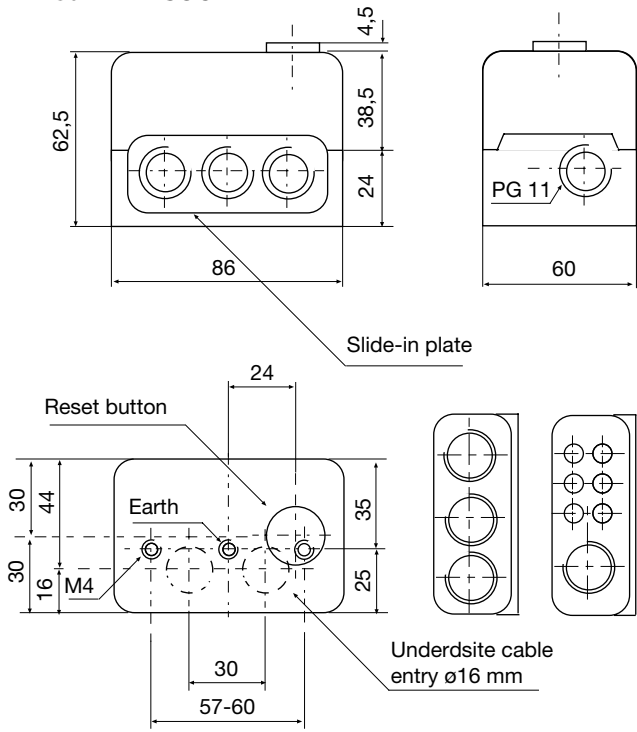

### PHOTORESISTOR FZ 711 S

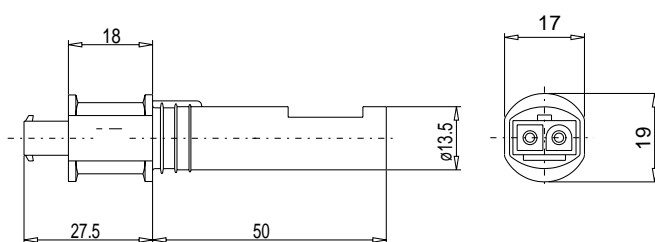

### HOLDER M74 FOR FZ, IRD OR UVD

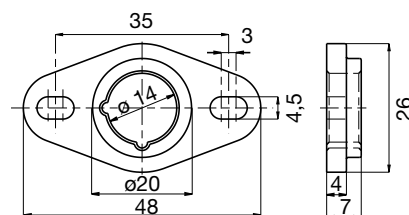

### UVD 970

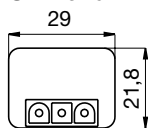

### IRD 1010

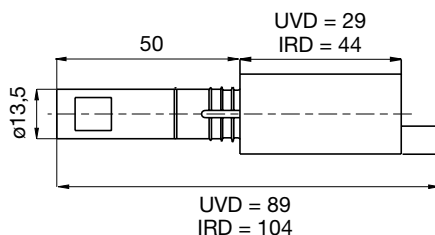
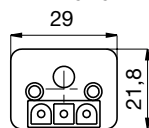

### VARIATION IRD

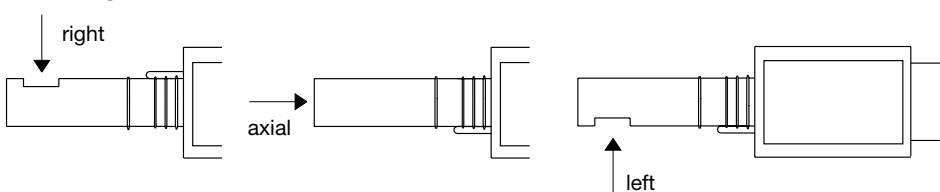

### ORDERING INFORMATION

ITEM	DESIGNATION	ITEM NO.
Control box	Type TF 801	02001
or	Type TF 801.2	02021
Control box	Type TF 802	02404
or	Type TF 802.2	02424
Socket	Socket 701 ABEN	70001
Insert plate	PG-Plate	70502
optional	Cable entry plate	70501
Flame detector	FZ 711 S red	40001
optional	FZ 711 S white	41001
optional	IRD 1010 right	16501
optional	IRD 1010 end-on	16502
optional	IRD 1010 left	16503
optional	UVD 970	16702
Support for flame detector	Holder M 74 for FZ, IRD, UVD	59074
Connectioncable IRD/FZ/UVD	Plug type, 3 core cable, 0.6 m, with tag wire ends	7236001
Connectioncable FZ 711 S	Plug type, 2 core cable, 0.5 m, with tag wire ends	7225001

The above ordering information refers to the standard version.  
Special versions are also included in our product range.

Specifications subject to change without notice

**TF 801 / 801.2**  
**TF 802 / 802.2**



A Honeywell Company

Satronic AG  
Brüelstrasse 7  
Postfach 324  
CH-8157 Dielsdorf

## Oil Burner Safety Control

**For 1- or 2-stage oil power burners up to 30kg/h capacity and intermittent operations.**

### Flame detection:

- Photoresistor FZ 771 S
- Infrared-flicker detector IRD 1010
- UV solid state sensor UVD 970

### APPLICATION RANGE

The TF 804 oil burner safety control box is suitable to control and monitor oil power burner with or without oil preheaters up to 30 kg/h capacity (approved and certified according to DIN 4787). The control boxes TF 804.2 is approved and certified according to EN230.

### TYPES AVAILABLE

TF 804	1-stage operation post-ignition time ca. 3-5 sec.
TF 804.2	1-stage operation post-ignition time ca. 3-5 sec. low voltage protection according to EN230

### CONSTRUCTIONAL FEATURES

The control box circuitry is protected by a flame resistant, transparent plastic housing. It incorporates the thermo-mechanical, temperature compensated timer, flame check and reset circuits.

Manual reset from lockout is provided by a push button with an integrated lockout signal lamp. A central fixing screw locks the control box to the wiring base. The wiring base and control box have a positive plug-in arrangement, making it impossible to achieve an incorrect connection between the two parts. A variety of cable entry points provides utmost flexibility of electrical wiring.

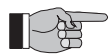

The TF 804.2 is fully compatible with the TF 704 and TF 804. The flame detector IRD 910 must be replaced by its compatible type IRD 1010. An optional extension button (item no. 70601) compensates for height differences.



### TECHNICAL DATA

Operating voltage	220/240V (-15..+10%) 50 Hz (40-60Hz)
Fuse rating	10 A fast, 6 A slow
Power consumption	ca. 5 VA
Max. load per output	
- terminal 3	1.5 A, cos φ 0.2
- terminal 4	4 A, cos φ 0.4
- terminal 5	0.5 A, cos φ 0.4
- terminal 6	4 A, cos φ 0.4
- terminal 7	0.1 A, cos φ 0.4
total load	5A, cos φ 0.4
Pre-purge time	ca. 12 sec.
Pre-ignition time	ca. 12 sec.
Post-ignition time	ca. 3-5 sec.
Lockout safety time	10 sec.
Reset time from lockout	ca. 60 sec
Flame detector:	
FZ 771 S red	side-on viewing
FZ 771 S white	side-on and end-on viewing
Light sensitivity FZ 711S	> 10 Lux
IRD 1010	side-on or end-on viewing
UVD 970	end-on viewing
Weight incl. wiring base	0.25 kg
Mounting position	any
Protection class	IP44
Recommended ambient operating temperature for control and flame detector	0°C...+60°C
approved and certified according to European standards	
TF 804.2	EN 230
TF 804	DIN 4787

## APPLICATION NOTES

### 1. Flame control

The following detectors can be used for flame control:

- For yellow oil flame: photoresistor FZ 771 S (red inscription: side-on; white inscription: side-on and end-on viewing)
- for blue or yellow flame: infrared-flicker detector type IRD 1010 or as alternative the UV solid state sensor UVD 970.

Using the photo resistor FZ 711 S, the no flame signal is generated at light levels below 3 Lux with respect to the operating cycle of the control. According to DIN74787 and EN 230 stray light safety level has to be established in conjunction with the accompanying burner.

Connecting the IRD 1010 or the UVD 970, the correct wiring has to be observed.

### 2. Burner control

With oil preheater:

- The fuel heater of the burner must have a temperature control switch. The closing contact-switch of the preheater has to be connected between terminals 4 and 6. A special contact in the control unit-connects the thermo-switch of the heater as soon as the burner is operating and a photocurrent is generated. Therefore an interruption of the burner operation due to a decrease in oil temperature is prevented (e.g. in case of high oil flow).
- According to EN 230 A2.1, the short circuiting of the thermo-switch is allowed only for an oil flow of max. 10 kg/h. Burners with a higher throughput have to shut down if the oil temperature gets below the allowed minimum. In such a case the thermo-switch has to be put in the phase-circuit and terminals 4 and 6 have to be connected with a link.

Without oil heater:

- In such a case the terminals 4 and 6 have to be connected with a link.

### 3. Low-voltage protection

TF 804.2 only

- The mains voltage has to be more than  $187 V_{\text{eff}}$  in order to allow the unit to perform a start-up.
- The mains voltage is not only monitored in the start-up phase but also permanently during operation. If the voltage drops below  $<160 V_{\text{eff}}$  during start-up or run time the control box goes into lockout mode. If the voltage rises again, the control box performs automatically a start-up as soon as the mains voltage is  $>187 V_{\text{eff}}$ .

### 4. Safety

The design and control sequence of the TF 804/TF 804.2 control boxes comply with the currently applicable European standards and regulations.

### 6. Mounting and electrical wiring

Wiring base:

- 3 earth terminals with additional terminal for burner earthing
- 3 neutral terminals with internal permanent connection to neutral terminal (terminal 7)
- 2 spare auxiliary terminals
- 2 slide in plates and 2 easy-knockout holes (PG 11 thread), plus 2 easy-knockout holes in the bottom of the base facilitate the wiring.
- The 3-wire sensor cable can be used for the IRD and UVD as well as for the FZ711 S. Please keep that in mind for burners which may be upgraded from FZ to IRD or UVD later on (e.g upgraded to a blue flame burner).

General:

- The control box can be mounted in any position. The protection class is IP44 (water spray tight). Neither the control box nor the flame detector should be subjected to excessive vibration.

## COMMISSIONING AND ROUTINE CHECKS

### 1. Important notes

- The controls must be installed by qualified personnel only. The relevant national regulations have to be observed.
- On commissioning the wiring has to be carefully checked according the appropriate diagram, Incorrect wiring can damage the unit and endanger the installation.
- The fuse rating has to ensure that the limits specified in TECHNICAL DATA will not be exceeded. If these precautions are not observed, the effect of a short circuit can cause severe damage to the control and installation.
- For safety reasons a minimum of one control shut-down per 24 hours has to be observed.
- Disconnect the mains before the control box is plugged in or out!
- The control box is a safety device and must not be opened!

### 2. Function control

For safety reasons the flame detection system should be tested on commissioning the installation as well as after a service or longer shut-down.

Condition: mains voltage  $>187 V_{\text{eff}}$  (for TF804.2 only)

- a) Start-up with covered flame detector
  - After lock-out safety time is over the unit has to go in to lockout mode!
- b) Start-up with exposed flame detector:
  - After 20 sec. pre-purge time the unit has to go into lockout mode!
- c) Normal start-up with burner in the normal position, cover up the flame detector:
  - After start-up, and end of lock-out safety time the unit has to go into lockout mode!
- d) The flame sensor signals can be checked either using the UP 940 or performing the following measurements:
  - For TF804 only: The measured sensor signal during operation should be minimal 2.4mA
  - For TF804.2 only: The sensor signal measurements are not reliable, as only marginal values changes occur. Measure instead the voltage across the photo resistor! For a reliable flame monitoring the DC voltage across the photo resistor (terminal 1 and 2) in operating mode should be less than 2 V.

### 3. Fault findings

Burner is not working:

- thermostat circuit open
- faulty electrical wiring
- mains voltage  $<187 V_{\text{eff}}$  (for TF804.2 only)

Burner starts, but the flame does not establish, a lock out occurs:

- stray light on flame detector
- no ignition or no fuel

Burner starts, the flame establishes, but after the safety time, a lock out occurs:

- dirty or faulty flame detector
- insufficient light on detector
- sensitivity adjustment too low on IRD.

For a quick and safe diagnosis use the Satronic UP 940 burner test box.

### CIRCUIT AND TIMING DIAGRAM TF 804/TF 804.2

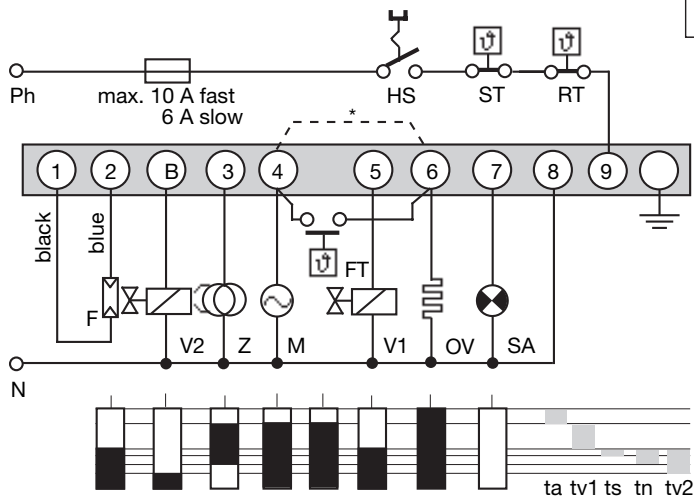

### IRD-OR UVD CONNECTION

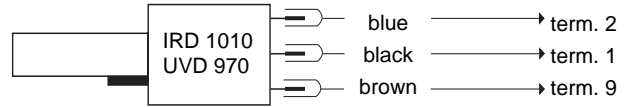

- HS Mains switch
- ST Limit thermostat
- RT Control thermostat
- F Flame detector FZ 711 S (IRD 1010, UVD 970 see separate diagram)
- Z Ignition
- M Burner motor (burner with solenoid valve)
- V1, V2 Solenoid valves
- OV Oil preheater
- FT Release thermostat
- SA External lock-out signal
- \* With burners without fuel heaters terminals 4 and 6 have to be connected with a jumper.

- ta Pre-heat-time
- tv1 Pre-ignition time with or without pre-purge
- ts Lock-out safety time
- tn Post-ignition time
- tv2 Delay 2nd stage

### SCHEMATIC DIAGRAM TF 804.2

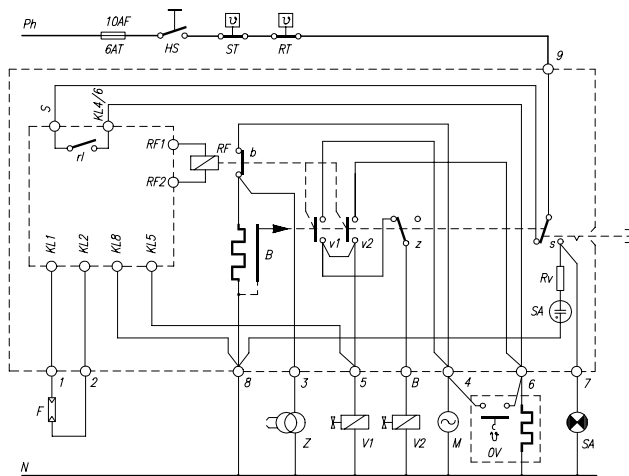

- HS Mains switch
- ST Limit thermostat
- RT Control thermostat
- SA Lock-out signal indicator
- F Flame detector MZ 770 S, IRD 1010 or UVD 970
- V Valves
- Z Ignition
- M Burner motor
- RF Flame relay
- r1 low voltage relay
- B Thermomechanical timer
- RV Resistor

### TF 804/804.2 AND SOCKET

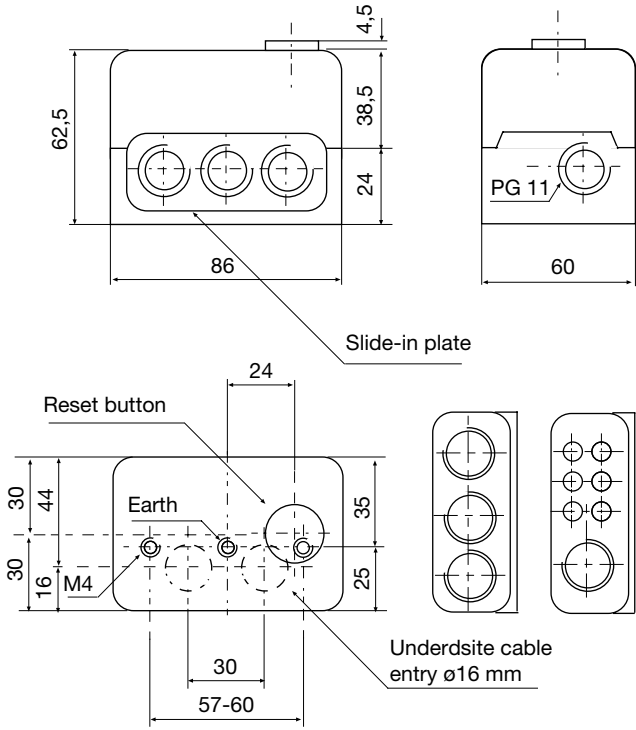

### PHOTORESISTOR FZ 711 S

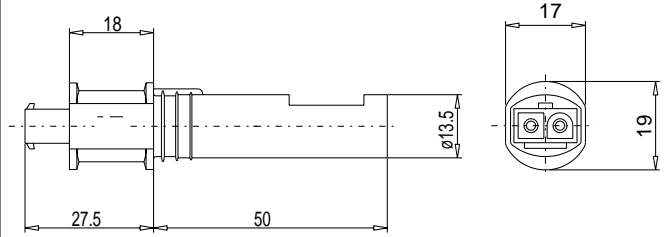

### HOLDER M74 FOR FZ, IRD OR UVD

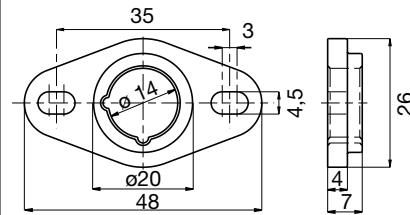

### UVD 970

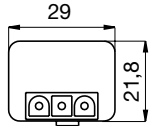

### IRD 1010

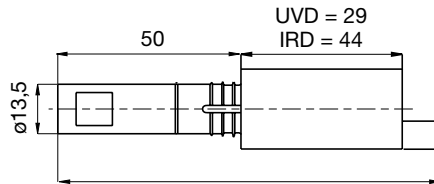
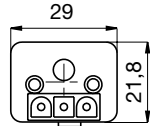

UVD = 89  
IRD = 104

### VARIATION IRD

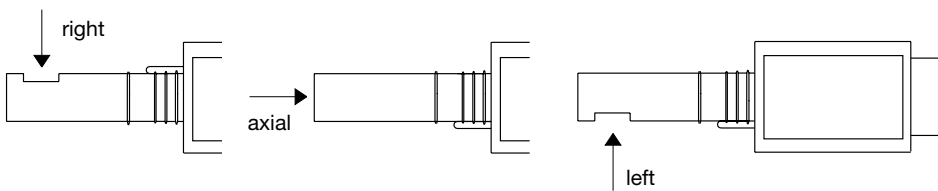

### ORDERING INFORMATION

#### ITEM

Control box  
or  
Socket  
Insert plate  
optional  
Flame detector  
optional  
optional  
optional  
optional  
optional  
Support for flame detector  
Connectioncable IRD/FZ/UVD  
Connectioncable FZ 711 S

#### DESIGNATION

Type TF 804  
Type TF 804.2  
Socket 701 ABEN  
PG-Plate  
Cable entry plate  
FZ 711 S red  
FZ 711 S white  
IRD 1010 right  
IRD 1010 end-on  
IRD 1010 left  
UVD 970  
Holder M 74 for FZ, IRD, UVD  
Plug type, 3 core cable, 0.6 m, with tag wire ends  
Plug type, 2 core cable, 0.5 m, with tag wire ends

#### ITEM NO.

02005  
02025  
70001  
70502  
70501  
40001  
41001  
16501  
16502  
16503  
16702  
59074  
7236001  
7225001

The above ordering information refers to the standard version.

Special versions are also included in our product range.

Specifications subject to change without notice

## TF 804 / 804.2

**satronic**

A Honeywell Company

Satronic AG  
Brüelstrasse 7  
Postfach 324  
CH-8157 Dielsdorf

## Oil Burner Safety Control

**For 1- or 2-stage oil power burners up to 30kg/h capacity and intermittent operations.**

### Flame detection:

- Photoresistor MZ 770 S
- Infrared-flicker detector IRD 1010
- UV solid state sensor UVD 970

### APPLICATION RANGE

The TF 830.3 or TF 832.3 oil burner safety control boxes are suitable to control and monitor oil power burner up to 30 kg/h capacity (approved and certified according to EN230).

### TYPES AVAILABLE

TF 830.3	1-stage operation post-ignition time ca. 20 sec. low voltage protection according to EN230
TF 832.3	2-stage operation post-ignition time 2-5 sec. low voltage protection according to EN230

### CONSTRUCTIONAL FEATURES

The control box circuitry is protected by a flame resistant, transparent plastic housing. It incorporates the thermo-mechanical, temperature compensated timer, flame check and reset circuits.

Manual reset from lockout is provided by a push button with an integrated lockout signal lamp. A central fixing screw locks the control box to the wiring base. The wiring base and control box have a positive plug-in arrangement, making it impossible to achieve an incorrect connection between the two parts. A variety of cable entry points provides utmost flexibility of electrical wiring.

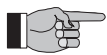

The TF 832.3 is fully compatible with the TF 730, 730-1 and TF 832. The flame detector IRD 911 must be replaced by its compatible type IRD 1010. An optional extension button (item no. 70601) compensates for height differences.



### TECHNICAL DATA

Operating voltage	220/240 V (-15...+10%)
	50 Hz (40-60Hz)
Fuse rating	10 A fast, 6 A slow
Power consumption	ca. 5 VA
Max. load per output	
- terminal 3	1.5 A, cos φ 0.2
- terminal 4	4.0 A, cos φ 0.4
- terminal 5	0.5 A, cos φ 0.4
- terminal 6	0.5 A, cos φ 0.4
- terminal 7	0.1 A, cos φ 0.4
total load	5.0 A, cos φ 0.4
Pre-purge time	ca. 12 sec.
Pre-ignition time	ca. 12 sec.
Post-ignition time	TF 830.3 TF 832.3
	ca. 20 sec.
	ca. 2-5 sec
Delay time to oil valve 2	40 sec. (TF 832.3)
Lockout safety time	10 sec.
Reset time from lockout	ca. 90 sec
Flame detector:	
MZ 770 S	side-on and end-on viewing
Light sensitivity MZ 770 S	> 6 Lux
IRD 1010	side-on or end-on viewing
UVD 970	end-on viewing
Sensor operating current	min. 30 μA
Weight incl. wiring base	0.25 kg
Mounting position	any
Protection class	IP44
Recommended ambient operating temperature for control and flame detector	0°C...+60°C
approved and certified according to European standards	EN 230

## APPLICATION NOTES

### 1. Flame control

The following detectors can be used for flame control:

- For yellow oil flame: photoresistor MZ 770 S
- for blue or yellow flame: infrared-flicker detector type IRD 1010 or as alternative the UV solid state sensor UVD 970.

Using the photo resistor MZ 770 S, the no flame signal is generated at light levels below 3 Lux with respect to the operating cycle of the control. According to EN 230 stray light safety level has to be established in conjunction with the accompanying burner.

Connecting the IRD 1010 or the UVD 970, the correct wiring has to be observed.

### 2. Burner control

For burners without an oil solenoid valve, the burner motor has to be connected to terminal 5.

### 3. Low-voltage protection

The start up of the burner can only take place if the mains voltage is higher than a limit which is 15% below nominal value. If the voltage drops below 160V, a start-up is prevented or – without allowing to release the fuel – the control box goes into lock out mode.

### 4. Safety

The design and control sequence of the TF 830.3 and TF 832.3 control boxes comply with the currently applicable European standards and regulations.

### 6. Mounting and electrical wiring

Wiring base:

- 3 earth terminals with additional terminal for burner earthing
- 3 neutral terminals with internal permanent connection to neutral terminal (terminal 8)
- 2 spare auxiliary terminals
- 2 slide in plates and 2 easy-knockout holes (PG 11 thread), plus 2 easy-knockout holes in the bottom of the base facilitate the wiring.

General:

- The control box can be mounted in any position. The protection class is IP44 (water spray tight). Neither the control box nor the flame detector should be subjected

## COMMISSIONING AND ROUTINE CHECKS

### 1. Important notes

- The controls must be installed by qualified personnel only. The relevant national regulations have to be observed.
- On commissioning the wiring has to be carefully checked according the appropriate diagram, Incorrect wiring can damage the unit and endanger the installation.
- The fuse rating has to ensure that the limits specified in TECHNICAL DATA will not be exceeded. If these precautions are not observed, the effect of a short circuit can cause severe damage to the control and installation.
- For safety reasons a minimum of one control shut-down per 24 hours has to be observed.
- Disconnect the mains before the control box is plugged in or out!
- The control box is a safety device and must not be opened!

### 2. Function control

For safety reasons the flame detection system should be tested on commissioning the installation as well as after a service or longer shut-down.

- a) Start-up with covered flame detector
  - After lock-out safety time is over the unit has to go in to lockout mode!
- b) Start-up with exposed flame detector:
  - After 20 sec. pre-purge time the unit has to go into lockout mode!
- c) Normal start-up with burner in the normal position, cover up the flame detector:
  - After start-up, and end of lock-out safety time the unit has to go into lockout mode!

### 3. Fault findings

Burner is not working:

- thermostat circuit open
- faulty electrical wiring
- mains voltage too low

Burner starts, but the flame does not establish, a lock out occurs:

- stray light on flame detector
- no ignition or no fuel
- mains voltage more than -15% below nominal value.

Burner starts, the flame establishes, but after the safety time, a lock out occurs:

- dirty or faulty flame detector
- insufficient light on detector
- sensitivity adjustment too low on IRD.

For a quick and safe diagnosis use the Satronic UP 940 burner test box.

### CIRCUIT AND TIMING DIAGRAM TF 830.3

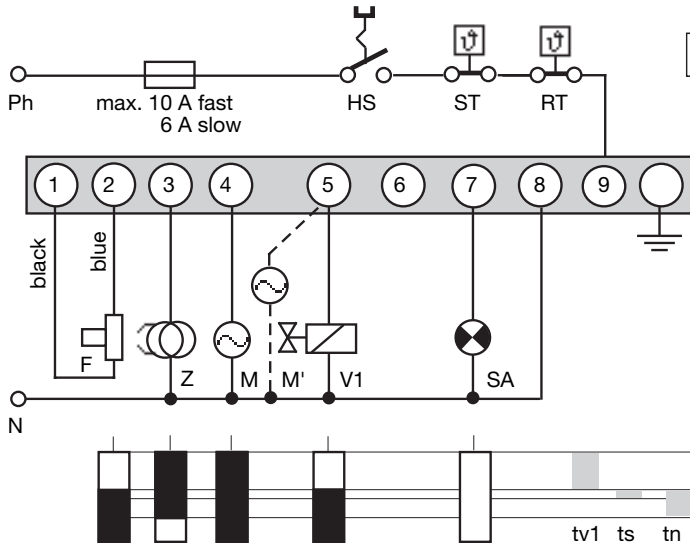

### IRD-OR UVD CONNECTION

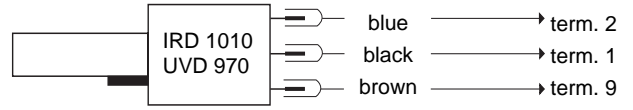

- HS Mains switch
- ST Limit thermostat
- RT Control thermostat
- F Flame detector MZ 770 S (IRD 1010, UVD 970 see separate diagram)
- Z Ignition
- M Burner motor (burner **with** solenoid valve)
- M' Burner motor (burner **without** solenoid valve)
- V1 Oil solenoid valve, 1st-stage
- SA External lock-out signal
- tv1 Pre-ignition time with or without pre-purge
- ts Lock-out safety time
- tn Post-ignition time

### CIRCUIT AND TIMING DIAGRAM 832.3

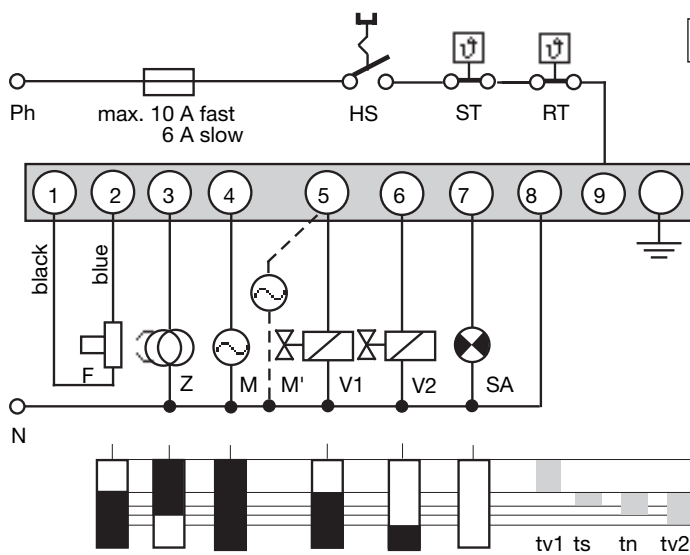

### IRD-OR UVD CONNECTION

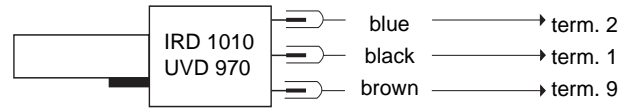

- HS Mains switch
- ST Limit thermostat
- RT Control thermostat
- F Flame detector MZ 770 S (IRD 1010, UVD 970 see separate diagram)
- Z Ignition
- M Burner motor (burner **with** solenoid valve)
- M' Burner motor (burner **without** solenoid valve)
- V1 Oil solenoid valve, 1st-stage
- V2 Oil solenoid valve, 2nd stage
- SA External lock-out signal
- tv1 Pre-ignition time with or without pre-purge
- ts Lock-out safety time
- tn Post-ignition time
- tv2 Delay 2nd stage

### SCHEMATIC DIAGRAM TF 830.3

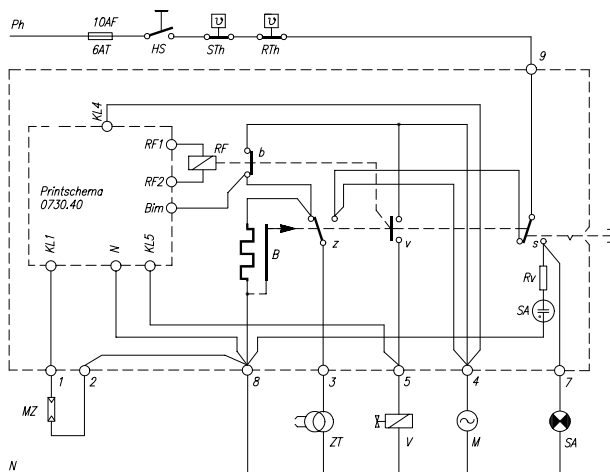

### SCHEMATIC DIAGRAM TF 832.3

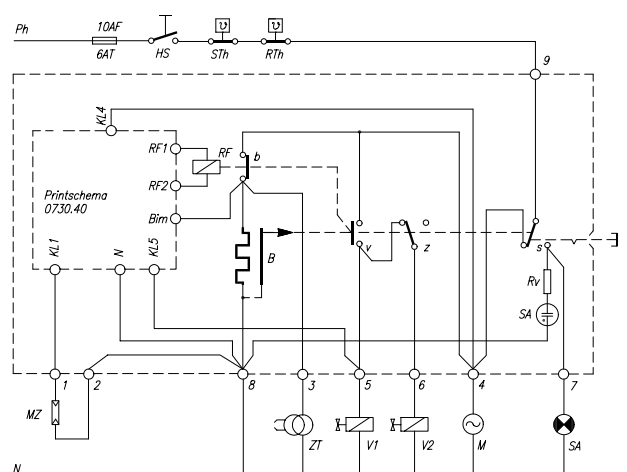

- HS Mains switch
- ST Limit thermostat
- RT Control thermostat
- SA Lock-out signal indicator
- F Flame detector MZ 770 S, IRD 1010 or UVD 970
- V Valves
- Z Ignition
- M Burner motor

- RF Flame relay
- r1 low voltage relay
- B Thermomechanical timer
- RV Resistor

### TF 83X AND SOCKET

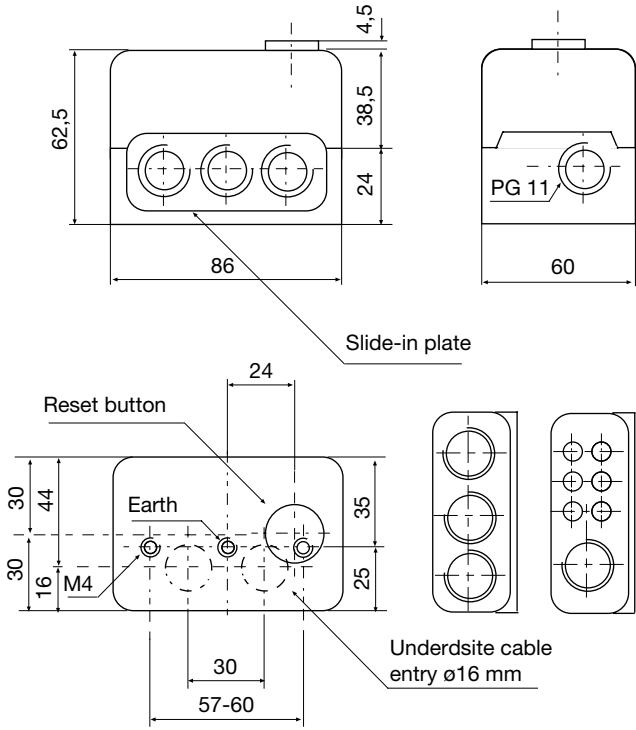

### HOLDER MZ 770 S

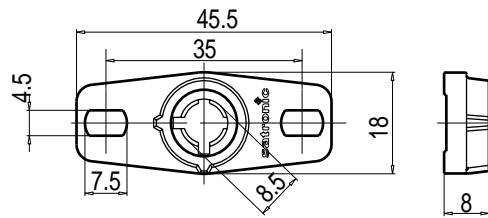

### SHAFT MZ 770 S

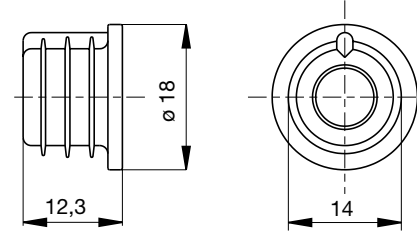

### PHOTORESISTOR MZ 770 S

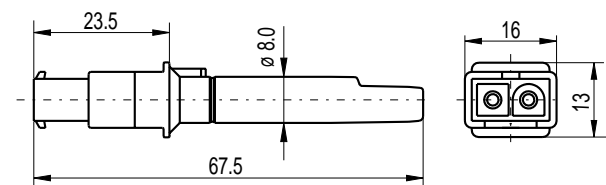

### UVD 970

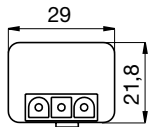

### IRD 1010

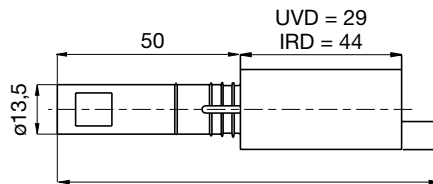
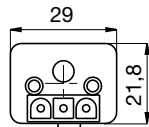

UVD = 89  
IRD = 104

### HOLDER M 74 FOR IRD OR UVD

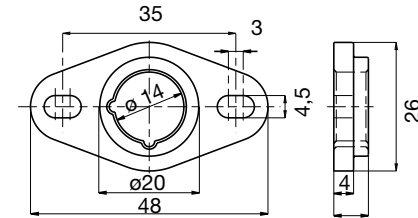

### VARIATION IRD

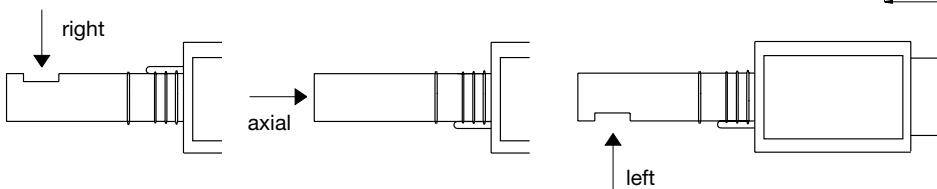

### ORDERING INFORMATION

ITEM	DESIGNATION	ITEM NO.
Control box	Type TF 830.3	02231
Control box	Type TF 832.3	02431
Socket	Socket 701 ABEN	70001
Insert plate	PG-Plate	70502
optional	Cable entry plate	70501
Flame detector	MZ 770 S	50001
optional	MZ 770 S mounted in shaft	51001
optional	IRD 1010 right	16501
optional	IRD 1010 end-on	16502
optional	IRD 1010 left	16503
optional	UVD 970	16702
Support for flame detector	Holder for MZ	59101
optional	Holder M 74 for IRD, UVD	59074
Connectioncable IRD/UVD	Plug type, 3 core cable, 0.6 m, with tag wire ends	7236001
Connectioncable MZ	Plug type, 2 core cable, 0.5 m, with tag wire ends	7225001

The above ordering information refers to the standard version.  
Special versions are also included in our product range.

Specifications subject to change without notice

## TF 830.3 / 832.3

**satronic**  
A Honeywell Company

Satronic AG  
Brüelstrasse 7  
Postfach 324  
CH-8157 Dielsdorf

## Oil Burner Safety Control

**For 1- or 2-stage oil power burners up to 30kg/h capacity with or without oil preheater and intermittent operations.**

### Flame detection:

- Photoresistor MZ 770 S
- Infrared-flicker detector IRD 1010
- UV solid state sensor UVD 970

### APPLICATION RANGE

The TF 834.3 or TF 836.3 oil burner safety control boxes are suitable to control and monitor oil power burner up to 30 kg/h capacity (approved and certified according to EN230). A special contact in the control unit short-circuits the thermo-switch of the oil preheater as soon as the burner is operating and the flame signal is present. Therefore interruption of the burner due to decreasing oil temperature (e.g. in case of high oil flow) can be prevented. If the control box goes into lock-out mode, the oil preheater power supply is also disconnected.

### TYPES AVAILABLE

TF 834.2	1-stage operation post-ignition time ca. 20 sec. low voltage protection according to EN230
TF 834 E.3	1-stage operation no post-ignition low voltage protection according to EN230.
TF 836.3	2-stage operation post-ignition time 2-4 sec. low voltage protection according to EN230

### CONSTRUCTIONAL FEATURES

The control box circuitry is protected by a flame resistant, transparent plastic housing. It incorporates the thermo-mechanical, temperature compensated timer, flame check and reset circuits.

Manual reset from lockout is provided by a push button with an integrated lockout signal lamp. A central fixing screw locks the control box to the wiring base. The wiring base and control box have a positive plug-in arrangement, making it impossible to achieve an incorrect connection between the two parts. A variety of cable entry points provides utmost flexibility of electrical wiring.

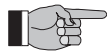

The TF 834 and TF 834 E are fully compatible with the TF 734 and TF 734-2 respectively. Using the TF 83X.3 as a replacement, the flame detector IRD 911 must be replaced by its compatible type IRD 1010.

An optional extension button (item no. 70601) compensates for height differences.



### TECHNICAL DATA

Operating voltage	220/240 V (-15..+10%)
	50 Hz (40-60Hz)
Fuse rating	10 A fast, 6 A slow
Power consumption	ca. 5 VA
Max. load per output	
- terminal 3	1.5 A, cos φ 0.2
- terminal 4	4.0 A, cos φ 0.4
- terminal 5	0.5 A, cos φ 0.4
- terminal 6	4.0 A, cos φ 0.4
- terminal 7	0.1 A, cos φ 0.4
- terminal B	0.5 A, cos φ 0.4
total load	5.0 A, cos φ 0.4
Pre-purge time	ca. 12 sec.
Pre-ignition time	ca. 12 sec.
Post-ignition time	TF 834.3 ca. 20 sec.
	TF 834 E.3 none
	TF 836.3 ca. 2-4 sec
Delay time to oil valve 2	ca. 20 sec. (TF 836.3)
Lockout safety time	10 sec.
Reset time from lockout	ca. 60 sec
Flame detector:	
MZ 770 S	side-on and end-on viewing
Light sensitivity MZ 770 S	> 6 Lux
IRD 1010	side-on or end-on viewing
UVD 970	end-on viewing
Sensor operating current	min. 30 µA
Weight incl. wiring base	0.25 kg
Mounting position	any
Protection class	IP44
Recommended ambient operating temperature for control and flame detector	0°C...+60°C
approved and certified according to European standards	EN 230

## APPLICATION NOTES

### 1. Flame control

The following detectors can be used for flame control:

- For yellow oil flame: photoresistor MZ 770 S
- for blue or yellow flame: infrared-flicker detector type IRD 1010 or as alternative the UV solid state sensor UVD 970.

Using the photo resistor MZ 770 S, the no flame signal is generated at light levels below 3 Lux with respect to the operating cycle of the control. According to EN 230 stray light safety level has to be established in conjunction with the accompanying burner.

Connecting the IRD 1010 or the UVD 970, the correct wiring has to be observed.

### 2. Burner control

With oil preheater:

The fuel heater of the burner must have a temperature control switch. The closing contact-switch of the preheater has to be connected between terminals 4 and 6. A special contact in the control unit-connects the thermo-switch of the heater as soon as the burner is operating and a photocurrent is generated. Therefore an interruption of the burner operation due to a decrease in oil temperature is prevented (e.g. in case of high oil flow).

According to EN 230 A2.1, the short circuiting of the thermo-switch is allowed only for an oil flow of max. 10 kg/h. Burners with a higher throughput have to shut down if the oil temperature gets below the allowed minimum. In such a case the thermo-switch has to be put in the phase-circuit and terminals 4 and 6 have to be connected with a link.

Without oil heater:

In such a case the terminals 4 and 6 have to be connected with a link.

### 3. Low-voltage protection

The start up of the burner can only take place if the mains voltage is higher than a limit which is 15% below nominal value. If the voltage drops below 160V, a start-up is prevented or – without allowing to release the fuel – the control box goes into lock out mode.

### 4. Safety

The design and control sequence of the TF 834.3, TF 834 E.3 and TF836.3 control boxes comply with the currently applicable European standards and regulations.

### 6. Mounting and electrical wiring

Wiring base:

- 3 earth terminals with additional terminal for burner earthing
- 3 neutral terminals with internal permanent connection to neutral terminal (terminal 8)
- 2 spare auxiliary terminals
- 2 slide in plates and 2 easy-knockout holes (PG 11 thread), plus 2 easy-knockout holes in the bottom of the base facilitate the wiring.

General:

- The control box can be mounted in any position. The protection class is IP44 (water spray tight). Neither the control box nor the flame detector should be subjected to excessive vibration.

## COMMISSIONING AND ROUTINE CHECKS

### 1. Important notes

- The controls must be installed by qualified personnel only. The relevant national regulations have to be observed.
- On commissioning the wiring has to be carefully checked according the appropriate diagram, Incorrect wiring can damage the unit and endanger the installation.
- The fuse rating has to ensure that the limits specified in TECHNICAL DATA will not be exceeded. If these precautions are not observed, the effect of a short circuit can cause severe damage to the control and installation.
- For safety reasons a minimum of one control shut-down per 24 hours has to be observed.
- Disconnect the mains before the control box is plugged in or out!
- The control box is a safety device and must not be opened!

### 2. Function control

For safety reasons the flame detection system should be tested on commissioning the installation as well as after a service or longer shut-down.

- a) Start-up with covered flame detector
  - After lock-out safety time is over the unit has to go in to lockout mode!
- b) Start-up with exposed flame detector:
  - After 20 sec. pre-purge time the unit has to go into lockout mode!
- c) Normal start-up with burner in the normal position, cover up the flame detector:
  - After start-up, and end of lock-out safety time the unit has to go into lockout mode!

### 3. Fault findings

Burner is not working:

- thermostat circuit open
- faulty electrical wiring
- mains voltage too low

Burner starts, but the flame does not establish, a lock out occurs:

- stray light on flame detector
- no ignition or no fuel
- mains voltage more than -15% below nominal value.

Burner starts, the flame establishes, but after the safety time, a lock out occurs:

- dirty or faulty flame detector
- insufficient light on detector
- sensitivity adjustment too low on IRD.

For a quick and safe diagnosis use the Satronic UP 940 burner test box.

### CIRCUIT AND TIMING DIAGRAM TF 834.3

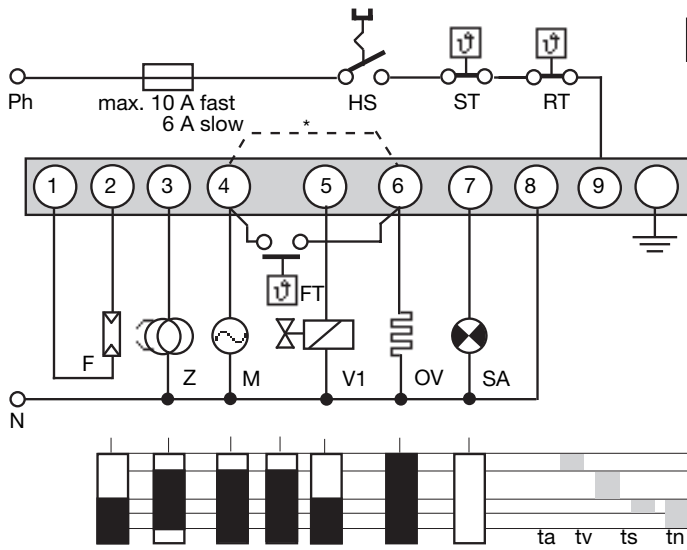

### IRD-OR UVD CONNECTION

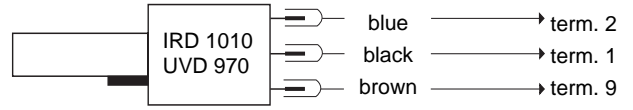

- HS Mains switch
  - ST Limit thermostat
  - RT Control thermostat
  - F Flame detector MZ 770 S (IRD 1010/UVD 970 see ssparate diagram)
  - Z Ignition
  - M Burner motor
  - FT Release thermostat oil preheater
  - V1 Oil solenoid valve
  - OV Oil preheater
  - SA External lock out signal
  - \* For burners without fuel heaters term. 4 and 6 have to be connected with a link
- 
- ta Pre-heat-time oil preheater
  - tv Pre-purge and pre-ignition time
  - tf stray light monitoring
  - ts Lock out safety time
  - tn Post-ignition time

### CIRCUIT AND TIMING DIAGRAM 836.3

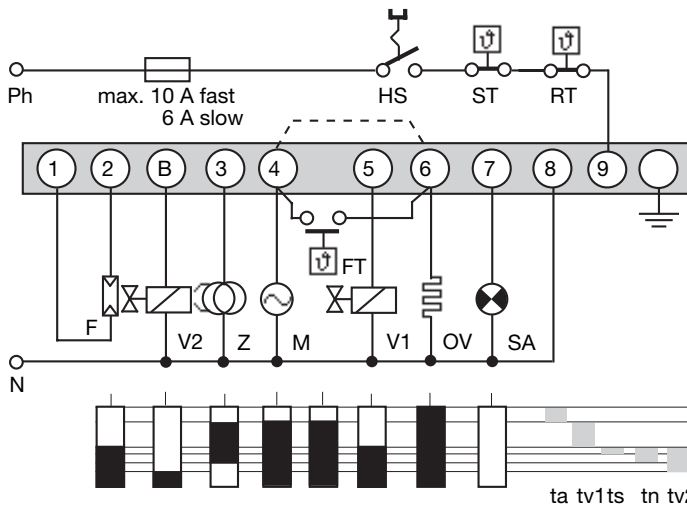

### IRD-OR UVD CONNECTION

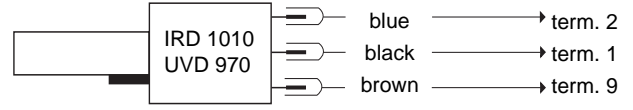

- HS Mains switch
  - ST Limit thermostat
  - RT Control thermostat
  - F Flame detector MZ 770 S (IRD 1010/UVD 970 see separate diagram)
  - Z Ignition
  - M Burner motor
  - V1, V2 Solenoid valves
  - OV Oil preheater
  - FT Release thermostat oil preheater
  - SA External lock out signal
  - \* With burners without fuel heaters term. 4 and 6 have to be connected with a link
- 
- ta Pre-heat-time oil preheater
  - tv1 Pre-purge and pre-ignition time
  - ts Lock out safety time
  - tn Post-ignition time
  - tv2 Delay time to oil V2

### SCHEMATIC DIAGRAMM TF 834.3

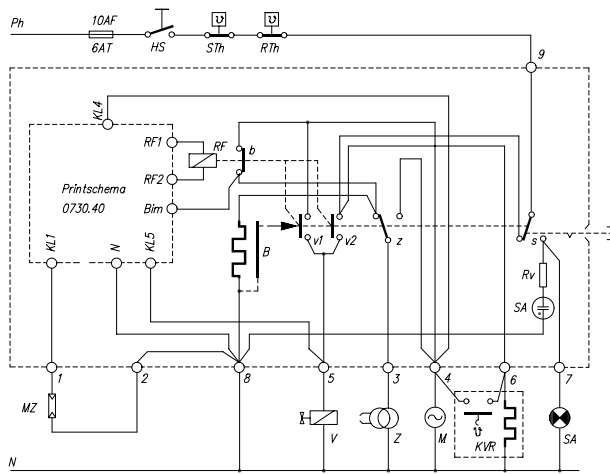

### SCHEMATIC DIAGRAMM TF 836.3

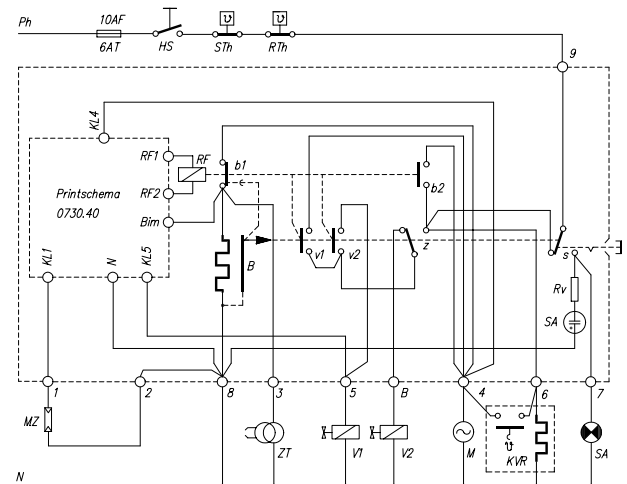

- |                              |  |                          |
|------------------------------|--|--------------------------|
| HS Mains switch              | F Flame detector MZ 770 S, IRD 1010 or UVD 970 | RF Flame relay           |
| ST Limit thermostat          | V Valves                                       | r1 low voltage relay     |
| RT Control thermostat        | Z Ignition                                     | B Thermomechanical timer |
| SA Lock-out signal indicator | M Burner motor                                 | RV Resistor              |
|                              | OV Oil preheater                               |                          |

### TF 83X AND SOCKET

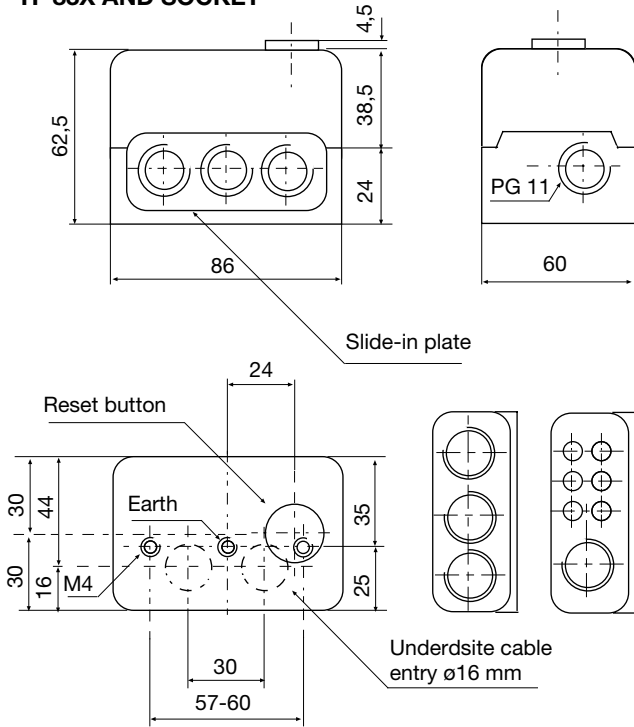

### HOLDER MZ 770 S

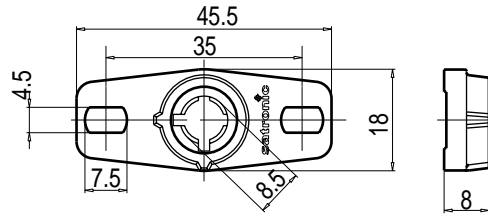

### SHAFT MZ 770 S

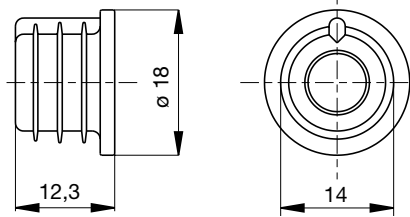

### PHOTORESISTOR MZ 770 S

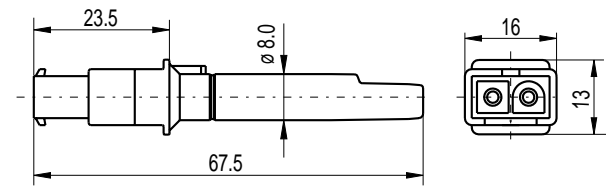

### UVD 970

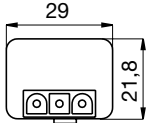

### IRD 1010

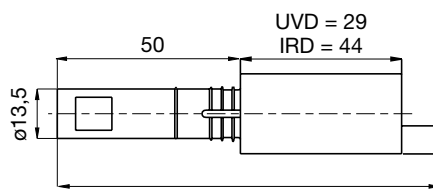
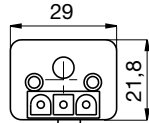

UVD = 89  
IRD = 104

### HOLDER M 74 FOR IRD OR UVD

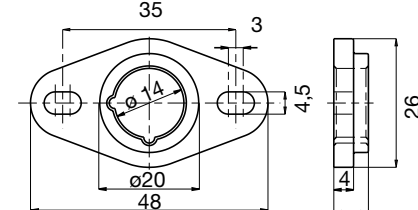

### VARIATION IRD

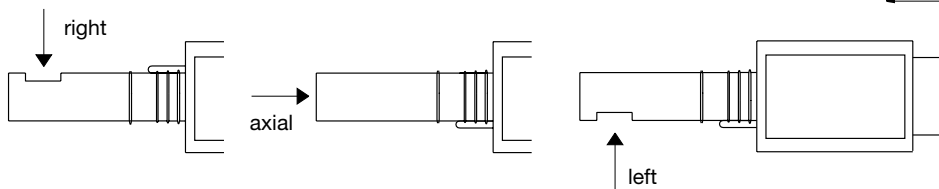

### ORDERING INFORMATION

ITEM	DESIGNATION	ITEM NO.
Control box	Type TF 834.3	02234
Control box	Type TF 834 E.3	02235
Control box	Type TF 836.3	02236
Socket	Socket 701 ABEN	70001
Insert plate	PG-Plate	70502
optional	Cable entry plate	70501
Flame detector	MZ 770 S	50001
optional	MZ 770 S mounted in shaft	51001
optional	IRD 1010 right	16501
optional	IRD 1010 end-on	16502
optional	IRD 1010 left	16503
optional	UVD 970	16702
Support for flame detector	Holder for MZ	59101
optional	Holder M 74 for IRD, UVD	59074
Connectioncable	Plug type, 3 core cable, 0.6 m, with tag wire ends	7236001
Connectioncable	Plug type, 2 core cable, 0.5 m, with tag wire ends	7225001

The above ordering information refers to the standard version.  
Special versions are also included in our product range.

Specifications subject to change without notice

## TF 834.3 / 836.3

**satronic**  
A Honeywell Company

Satronic AG  
Brüelstrasse 7  
Postfach 324  
CH-8157 Dielsdorf

## Oil burner safety control

**For 1- or 2-stage oil burners up to 30 kg/h throughput and intermittent operation with or without oil preheating**

### Flame detection:

- Photo resistor MZ 770 S
- Infrared-flicker detector IRD 1010
- UV flame sensor UVD 970

### INTRODUCTION

The TF 974 or TF 976 oil burner safety control boxes are suitable for oil burners which may be equipped with a oil preheater up to 30 kg/h capacity. The control boxes are approved and certified according to EN 230.

A special contact in the control unit short-circuits the thermo-switch of the fuel heater as soon as the burner is operating and the flame signal is present. Therefore interruption of the burner operation due to decreasing oil temperature can be prevented (e.g. in case of high oil flow).

If the control box goes into lock-out mode, the oil preheater power supply is also disconnected.

### TYPES AVAILABLE

TF 974	1-stage operation post-ignition time ca. 20 sec. low voltage protection according to EN 230
TF 976	2-stage operation post-ignition time ca. 2 - 4 sec. low voltage protection according to EN 230

### CONSTRUCTIONAL FEATURES

The control box circuitry is protected by a flame resistant, transparent housing. It incorporates the thermomechanical, temperature compensated, flame check and reset circuits.

Manual reset from lockout is provided by a push button with an integrated lockout signal lamp. A central fixing screw locks the control box to the wiring base. The wiring base and control box have a positive plug-in arrangement, making it impossible to achieve an incorrect connection between the two parts.

A variety of cable entry points provides the utmost flexibility for electrical wiring.



### TECHNICAL DATA

Operating voltage	220 / 240 V (-15... +10%) 50 Hz (40 - 60 Hz)
Fuse rating	10 A fast, 6 A slow
Power consumption	ca. 5 VA
Max. current rating output terminal	term. 2 0.5 A, cos φ 0.4 term. 3 1.5 A, cos φ 0.2 term. 4 4 A, cos φ 0.4 term. 5 0.5 A, cos φ 0.4 term. 6 4 A, cos φ 0.4 term. 8 0.1 A, cos φ 0.4 total 5 A, cos φ 0.4
Pre-purge time	ca. 12 sec.
Pre-ignition time	ca. 12 sec.
Post-ignition time	ca. 20 sec. TF 974 2 - 4 sec. TF 976
Delay time to oil valve V 2	ca. 20 sec. TF 976
Lockout safety time	10 sec.
Reset time from lockout	ca. 60 sec.
Flame detector	
MZ 770 S	for side-on and end-on viewing
Light sensitivity	> 6 Lux
Sensor operating current	min. 30 μA
IRD 1010	for side-on or end-on viewing
UVD 970	end-on viewing
Weight incl. wiring base	0,25 kg
Mounting position	any
Protection class	IP 40
Recommended ambient operating temperature for control and flame detector approved according to	0° C... +60° C EN 230

## UV SOLID STATE SENSOR UVD 970 APPLICATION NOTES

### 1. Flame control

The following flame detectors can be used for flame control:

- For yellow oil flame: photoresistor MZ 770 S (side-on or end-on viewing).
- For blue or yellow oil flame: infrared-flame detector type IRD 1010 or as an alternative the UV solid state sensor UVD 970.

Generally, the no flamesignal is generated at light levels below 3 Lux with respect to the operating cycle of the control. According to EN 230 stray light safety level has to be established in conjunction with the accompanying burner. Connecting the IRD 1010 or UVD 970, the correct wiring has to be observed.

### 2. Burner control

The fuel heater of the burner must have a temperature control switch. The closing contact-switch of the preheater has to be connected between terminals 4 and 6. A special contact in the control unit-connects the thermostich of the heater as soon as the burner is operating and a photocurrent is generated. Therefore an interruption of the burner operation due to a decrease in oil temperature is prevented (e.g. high oil flow).

According to EN 230 A2.1, the short circuiting of the thermostich is allowed only for an oil flow of max. 10 kg/h oil. Burners with a higher throughput have to shut down if the oil temperature gets below the allowed minimum. In such a case the thermostich has to be put in the phasecircuit and terminals 4 and 6 are connected with a link.

With burners without fuel heaters terminals 4 and 6 have to be connected with a jumper.

### 3. Low Voltage Protection

The start up of the burner can only take place if the mains voltage is higher than a limit which is 15% below nominal value. If the voltage drops below 160V, a start-up is prevented or – without allowing to release the fuel – the control box goes into lock out mode.

### 4. Safety

The design and the control sequence of the TF 974 and TF 976 control boxes comply with the currently applicable Eu-ropean standards and regulations.

### 5. Mounting and electrical wiring

Wiring base:

- 3 earth terminals with additional terminal for burner earthing
- 3 neutral terminals with internal permanent connection to neutral terminal (terminal 7)
- 2 spare auxiliary terminals
- 2 slide-in plates and 2 easy-knockout holes (PG 11 thread), plus 2 easy-knockout holes in the base bottom facilitate the base wiring.

General:

- Control box and flame detector should not be subjected to excessive vibration.
- The control box can be mounted in any position. The protection class is IP 40.

## INSTALLATION INSTRUCTIONS AND MAINTENANCE

### 1. Important notes

- The controls must be installed by qualified personnel only. The relevant national regulations have to be observed.
- On commissioning the wiring has to be carefully check according to the appropriate diagram. Incorrect wiring can damage the unit and endanger the installation.
- The fuse rating has to ensure that the limits specified in Technical Data will not be exceeded. If these precautions are not observed, the effect of a short circuit can cause severe damage to the control and installation.
- For safety reasons a minimum of one control shut-down per 24 hours has to be observed.
- Disconnect the mains before the control box is plugged in or out!
- The control box is a safety device and must not be opened!

### 2. Function control

For safety reasons the flame detection system should be tested on commissioning the installation as well as after a service or a longer shut-down.

- a) Start-up with covered flame detector:
  - After lock-out safety time
  - >lockout
- b) Start-up with exposed flame detector:
  - After ca. 20 sec. pre-purge:
  - >lockout
- c) Normal start-up; with burner in the "normal" position, cover up the flame detector:
  - New start-up, after end of lock-out safety time
  - >lockout

### 3. Fault finding

Burner not working:

- faulty electrical wiring
- thermostat circuit open
- oil preheater defective
- mains voltage below 160V

Burner starts, flame not established = lockout:

- stray light on flame detector.
- no ignition or no fuel.
- mains voltage more than -15% below nominal value.

Burner starts, flame established, after safety time = lockout:

- dirty or faulty flame detector
- insufficient light on detector
- sensitivity adjustment too low on IRD

**CIRCUIT AND TIMING DIAGRAM TF 974**

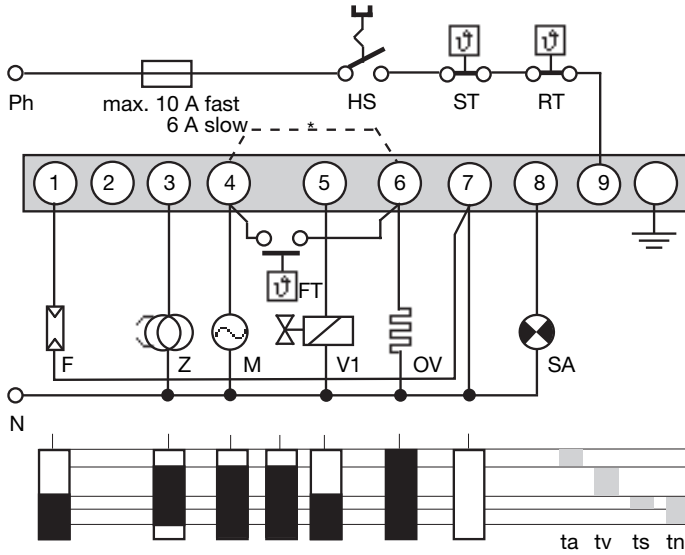

**IRD - / UVD-CONNECTION**

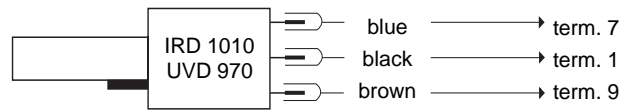

- HS Mains switch
- ST Limit thermostat
- RT Control thermostat
- F Flame detector MZ 770 S (IRD 1010/UVD 970 see separate diagram)
- Z Ignition
- M Burner motor (burner with solenoid valve)
- FT Release thermostat oil preheater
- V Oil solenoid valve
- OV Oil preheater
- SA External lock-out signal.
- \* For burners without fuel heaters terminals 4 and 6 have to be connected with a link.
- ta Preheat-time oil preheater
- tv Pre-ignition time with or without pre-purge
- ts Lock-out safety time
- tn Post-ignition time

**CIRCUIT AND TIMING DIAGRAM TF 976**

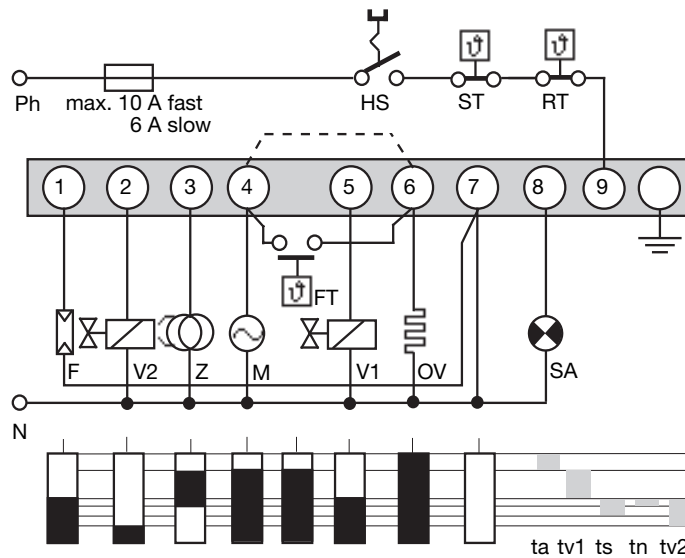

**IRD - / UVD CONNECTION**

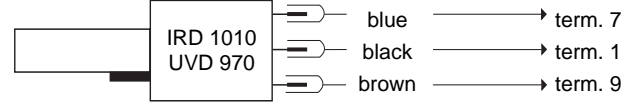

- HS Mains switch
- ST Limit thermostat
- RT Control thermostat
- F Flame detector MZ 770 S (IRD 1010/UVD 970 see separate diagram)
- Z Ignition
- M Burner motor (burner with solenoid valve)
- V1, V2 Oil solenoid valves
- FT Release thermostat oil preheater
- OV Oil preheater
- SA External lock-out signal.
- \* For burners without fuel heater terminals 4 and 6 have to be connected with a link
- ta Preheat-time oil preheater
- tv1 Pre-ignition time with or without pre-purge
- ts Lock-out safety time
- tn Post ignition time
- tv2 Delay 2nd stage

**SCHEMATIC DIAGRAM TF 974**

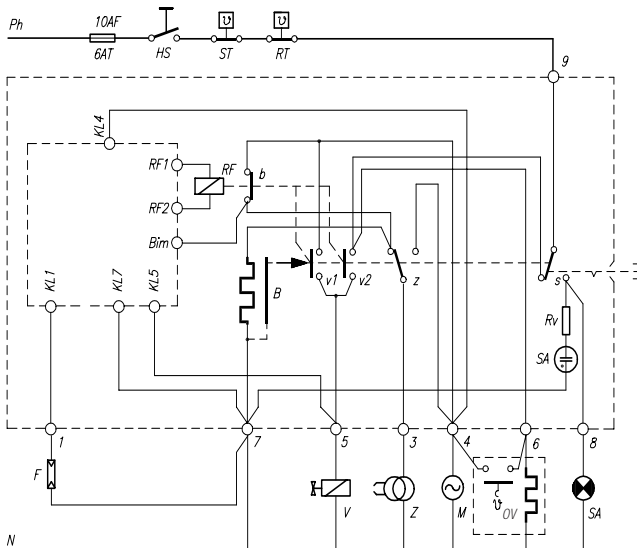

**SCHEMATIC DIAGRAM TF 976**

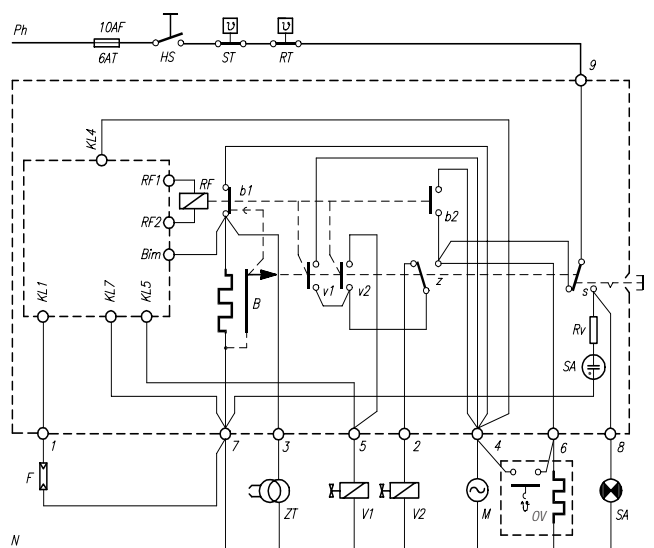

- HS Mains switch
- ST Limit thermostat
- RT Control thermostat
- SA Lock-out signal indicator
- F Flame detector MZ 770 S
- V Valves
- Z Ignition
- M Burner motor
- OV Oil preheater
- RF Flame relay
- B Thermomechanical timer
- RV Resistor

### TF 974 / 976 AND SOCKET

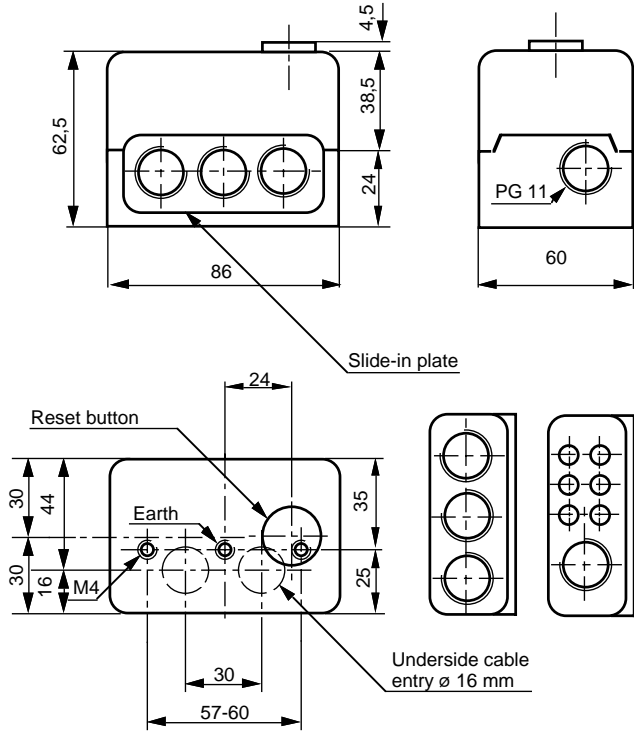

### HOLDER FOR MZ 770 S

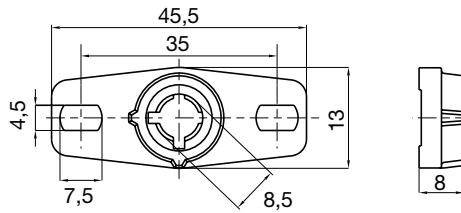

### SHAFT MZ 770 S

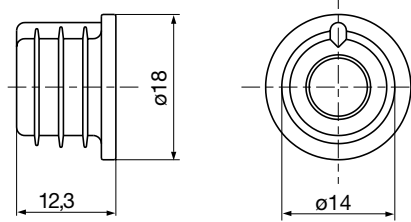

### PHOTORESISTOR MZ 770 S

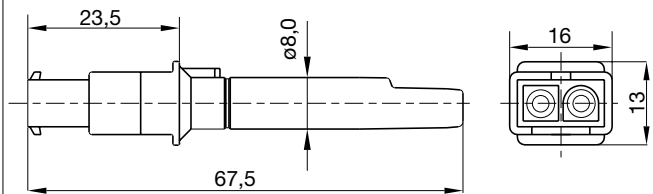

### IRD 1010

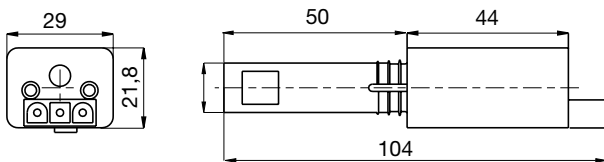

### UVD 974

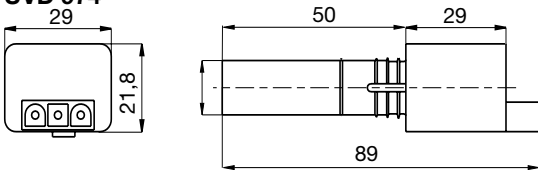

### HOLDER M 74 FOR IRD OR UVD

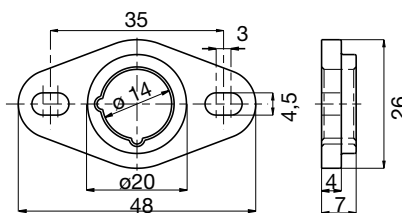

### ORDERING INFORMATION

ITEM	DESIGNATION	ITEM NO.
Control box	Typ TF 974	02524
or	Typ TF 976	02526
Socket	Socket 701 ABEN 7	70011
Insert plate	PG-Plate	70502
optional	Cable entry plate	70501
Flame detector	MZ 770 S	50001
optional	MZ 770 S with shaft	51001
optional	IRD 1010 right	16501
optional	IRD 1010 end-on	16502
optional	IRD 1010 left	16503
optional	UVD 970	16702
Support for flame detector	Holder for MZ 770 S	59100
optional	Holder M74 for IRD or UVD	59074
Connectioncable	Plug type, 3 core cable, 0.6 m with tag wire ends	7236001
Connectioncable	Plug type, 2 core cable, 0.6 m with tag wire ends	7225001

The above ordering information refers to the standard version.

Special versions are also included in our product range.

Specifications subject to change without notice

## TF 974 / 976

A Honeywell Company

Satronic AG  
Brüelstrasse 7  
Postfach 324  
CH-8157 Dielsdorf

## Oil Burner Safety Control

**For 1- or 2-stage oil burners up to 30 kg/h throughput and intermittent operation**

**Flame detection:**

- Photoresistor MZ 770 S
- Infrared-flicker detector IRD 1010
- UV flame sensor UVD 970

### INTRODUCTION

The DKO 970/972 oil burner safety control boxes are suitable for oil burners with throughputs up to 30 kg/h. They are approved and certified according to the applicable European standards and regulations.

The microprocessor-based programming sequence ensures extremely stable timings independent of voltage variations, ambient temperature and/or switch-on cycles. The built-in information system not only provides a continuous monitoring of the actual state of the box (very helpful especially for monitoring the start-up phase) but also informs about the cause of a possible lock out. The lock out cause is stored in such a way that it can be retrieved even after a power failure.

The control box is designed for maximum safety in case of fluctuations in the voltage supply. If the mains voltage drops below the permitted level, operation is interrupted and the control box automatically prevents the start sequence from being repeated. In this way, the safety of the system is not put at risk by a drop in the mains voltage. This low-voltage protection works not only during start-up but also permanently during operation.

### TYPES AVAILABLE

- DKO 970 1-stage operation
- DKO 972 2-stage operation

### CONSTRUCTIONAL FEATURES

The control box circuitry is protected by a flame resistant, transparent plug-in type plastic housing. A central fixing screw locks the control box to the wiring base.

The plug-in control box incorporates the microprocessor based timer, flame check and reset circuits.

Manual reset from lock out and set to lock out is provided by a push button with an integrated LED information system. The wiring base S98 is equipped with spare- and extraterminals and allows together with a variety of cable entry points utmost flexibility of electrical wiring.

The DKO 970 is compatible with the TF 801, TF 801.2, TF 830, TF 830.2. The DKO 972 is in addition compatible with the TF 802, TF 802.2, TF 832, TF 832.2.



Using the DKO 970/972 as a replacement for the TF 801 or TF 801.2, the flame sensor FZ 711 S must be replaced by its compatible type MZ 770 S.

### Timings (sec.)

Model	waiting time start	Pre-purge and pre-ignition time <b>tv1</b>	stray light monitoring <b>tf</b>	safety time <b>ts</b>	post-ignition time after V1 <b>tn</b>	delay time to V2 DKO 972 only <b>tv2</b>
<b>05</b>	0	15	5	5	7	20



### TECHNICAL DATA

Operating voltage	220 / 240 V (-15... +10%) 50 Hz (±5%)
Fuse rating	10 A fast, 6 A slow
Power consumption	ca. 15 VA
Max. load per output	
- term. 3 ignition trafo	1.0 A, cos φ 0.2
- term. 4 motor	2.0 A, cos φ 0.4
- term. 5 + 6 solenoid valves	0,5 A, cos φ 0.4
- term. 7 alarm indicator	0,5 A, cos φ 0.4
total load	4.0 A, cos φ 0.4
max. 6 A during 0,5 sec	
Reset time from lock out	none
Flame detectors	< 2 m length of cable
MZ 770 S	side-on and end-on viewing
Light sensitivity	better 6 Lux
IRD 1010	side-on or end-on viewing
UVD 970	end-on viewing
Weight incl. Wiring base	190 g
Mounting position	any
Protection class	IP 40
Approved ambient parameter for control and flame detector	max. 95% bei 30° C
- for operation	0° C... +60° C
- for storage	-20° C... +80° C
Build-up of ice, penetration of water and condensing water are	inadmissible
Approvals according to European standards	EN 230, as well as all other relevant Directives and standards

## APPLICATION FEATURES

### 1. Information system

The information system is microprocessor based and reports on all aspects of burner control box operation and flame supervision. It informs continuously about the actual programming sequence the unit is just performing. Besides monitoring of the programming sequence it also allows to identify errors during start-up of operation without any additional testing devices. The automatically performed diagnoses is a valuable tool which facilitates service/maintenance work and therefore saves costs. The analyses of the error cause can be done directly on stage or if not possible afterwards as the lock out reason is stored in a non-volatile lock out mode memory.

The information system communicates with the outside world using a LED (the used Flash-Code is similar to the Morse-Code). The messages are optically transmitted by flashing appropriately a LED. Using an (optional) additional terminal the messages can be recorded and displayed in easy readable form.

#### 1.1 Programming sequence display

The built-in microprocessor controls not only the programming sequence but the information system too. The individual phases of the programming sequence are displayed as Flash-Code.

The following messages can be distinguished:

Message	Flash-Code
pre-ignition tv1	.
safety time ts post ignition tn	■   .
delay time to valve V2 tv2	■     .
running	_
low mains voltage	■ ■ _

#### Description

- | = short pulse
- = long pulse
- . = short pause
- \_ = long pause

### 1.2 Lock-out diagnoses

In case of a failure the LED is permanently illuminated. Every 10 seconds the illumination is interrupted by a flash code, which indicates the cause of the error. Therefore the following sequence is performed which is repeated as long as the unit is not reset.

Sequence:

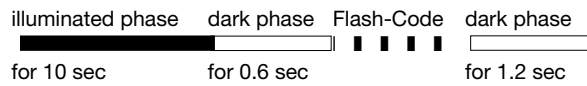

#### Error diagnosis

Error message	Flash-Code	Possible fault
lockout	■ ■ ■ ■	within lock out safety time no flame establishment
stray light	■ ■ ■	stray light during monitored phase, detector may be faulty

#### Flash-Code for manual lock out

manual/external | | ■ ■ ■ \_ ■ ■ ■ ■ ■

lock out

(see also 3. lock out and reset)

### 2. Flame control

The following detectors can be used for flame supervision:

- for yellow oil flame: photoresistor MZ 770 S (side-on and end-on viewing)
- for blue or yellow flame: infrared-flicker detector type IRD 1010 or as an alternative the UV solid state flame sensor UVD 970.

Generally, the no flame signal is generated at light levels below 3 Lux with respect to the operating cycle of the control. According to EN 230 stray light safety level has to be established in conjunction with the accompanying burner. Connecting the IRD 1010 or UVD 970 the correct wiring has to be observed.

#### 2.1 Stray light monitoring

The stray light check is performed at the end of the pre-purge time for thr duration as mentioned in the technical datas.

### 3. Lock out and reset

The unit can be reset or brought into lock out mode in two different ways:

#### Internal

In the lock out case the unit can be reset by pushing the built-in button meaning a new start-up cycle is performed.

#### External

Instead of using the built-in lock out button the same function can be achieved by using an external button which connects terminal 9 with A (see also circuit and block diagram).

If the pushbutton (internal or external) is pressed during normal operation or during the start sequence for more than 3 sec. and afterwards released, the control box will perform a shutdown.

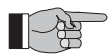

#### Please note

The unit can only be brought to lockout mode or be reset if power is applied to the unit.

### 4. Low-voltage protection

The mains voltage has to be more than  $187 V_{eff}$  in order to allow the unit to perform a start-up.

The mains voltage is not only monitored in the start-up phase but also permanently during operation. If the voltage drops below  $< 160 V_{eff}$  during start-up or run time the control box goes into lock out mode. If the voltage rises again, the control box performs automatically a start-up as soon as the mains voltage is  $> 187 V_{eff}$ .

### 5. Safety

The design and control sequence of the DKO 970/972 controls will comply with the currently applicable standards and regulations (see also TECHNICAL DATA).

### 6. Mounting and electrical wiring

Wiring base:

- 3 earth terminals with additional terminal for burner earthing
- 3 neutral terminals with internal permanent connection to neutral terminal 8
- 2 independent spare terminals (S1 and S2)
- extra terminals A, B and C are standard
- 2 slide-in plates and 2 easy knock out holes (PG11 thread) plus 2 knock out holes in the base bottom facilitate the base wiring

The digital controls are ideally wired on the new wiring bases S98, which are equipped with (terminals B and C are only for some special types of DMO or DMG) terminal A, which is used for the remote reset / remote lockout functions.



#### Please note

To assist trouble-free operation the main neutral connection terminal in the wiring base must be fully tightened. The terminal screws are already in the undone position. To connect a wire to the terminal, the screw only needs to be fastened.

General: The control box and detector probes should not be subjected to excessive vibration.

## INSTALLATION INSTRUCTIONS AND MAINTENANCE

### 1. Important notes

- The controls must be installed by qualified personnel only. The relevant national regulations have to be observed.
- On commissioning the wiring has to be carefully checked according to the appropriate diagram. Incorrect wiring can damage the unit and endanger the installation.
- The fuse rating has to ensure that the limits specified in TECHNICAL DATA will not be exceeded. If these precautions are not observed, the effect of a short circuit can cause severe damage to the control and installation.
- For safety reasons a minimum of one control shutdown every 24 hours has to be observed.
- Disconnect the mains before the control box is plugged in or out.
- The control box is a safety device and must not be opened!

### 2. Function control

For safety reasons the flame detection system should be tested on commissioning the installation as well as after a service or longer shut-down.

- Start-up with covered flame detector
  - After lock out safety time is over the unit has to go into lock out mode!
- Start-up with exposed flame detector
  - After 12 sec prepurge time the unit has to go into lock out mode!
- Normal start-up with burner in the normal position, cover up the flame detector
  - After start-up, and end of lock out safety time the unit has to go into lock out mode!

### 3. Fault finding

The built-in information system facilitates the trouble shooting in the case of problems occurring during start-up or during operation.

A list of possible lock out messages can be found in APPLICATION FEATURES chapter 1.2.

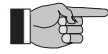

#### Please note:

**The control box is locked in lock out mode and the reason for the lock out is displayed until the control box is reset, either by an internal or external reset (see also subject "3. Lock out and reset").**

Removing the control box from its wiring base or by interrupting the supply line may **not** reset a lock out (according to EN 230). Therefore, by applying power, the fan motor switches on for 2-3 secs. before the control box goes to lock out again and the cause of the last lock out.

Error	Possible fault
Burner not working	- Thermostat circuit open - Faulty electrical wiring - Oil preheater defective - mains voltage < 187 V
Fan motor starts for a short period of time, control box goes to lock out	- Control box has not been reset
Burner starts, flame not established, lock out	- Stray light on flame detector - No ignition or no fuel
Burner starts, flame established, after safety time, lock out	- Dirty or faulty flame detector - Insufficient light on detector - Sensitivity adjustment too low on IRD

### CIRCUIT AND TIMING DIAGRAM DKO 970

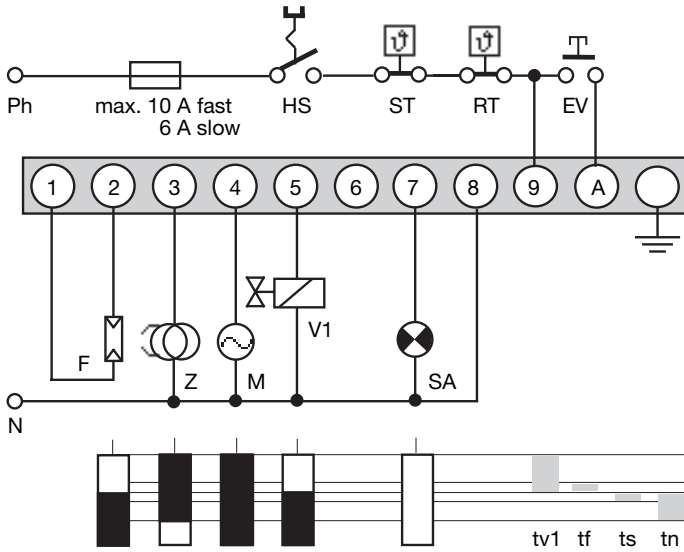

### IRD-/UVD-CONNECTION

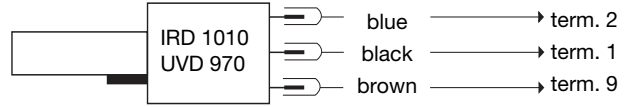

- HS Mains switch
- ST Limit thermostat
- RT Control thermostat
- EV External reset and lock out button
- F Flame detector MZ 770 S (IRD 1010, UVD 970 see separate diagram)
- Z Ignition
- M Burner motor
- V1 Oil solenoid valve, 1st-stage
- SA External lock out signal
- tv1 Pre-purge and pre-ignition time
- tf stray light monitoring
- ts Lock out safety time
- tn Post-ignition time

### CIRCUIT AND TIMING DIAGRAM DKO 972

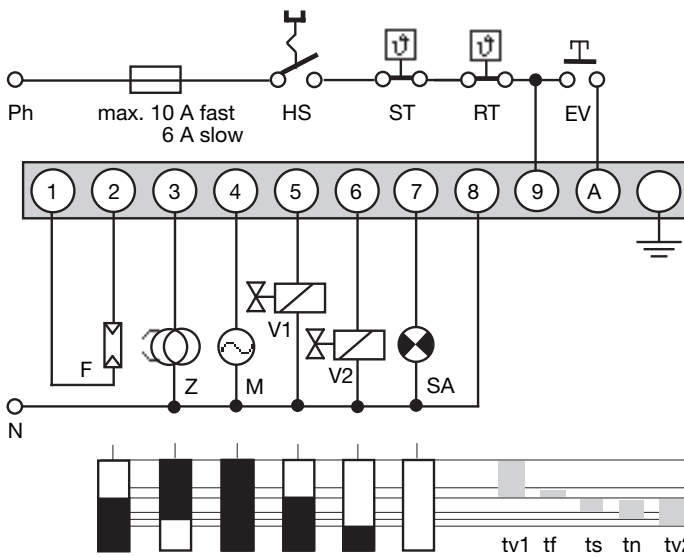

### IRD-/UVD-CONNECTION

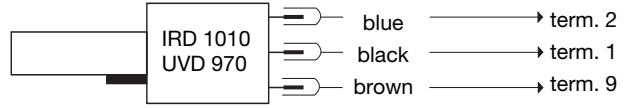

- HS Mains switch
- ST Limit thermostat
- RT Control thermostat
- EV External reset and lock out button
- F Flame detector MZ 770 S (IRD 1010, UVD 970 see separate diagram)
- Z Ignition
- M Burner motor
- V1 Oil solenoid valve, 1st-stage
- V2 Oil solenoid valve, 2nd-stage
- SA External lock out signal
- tv1 Pre-purge and pre-ignition time
- tf stray light monitoring
- ts Lock out safety time
- tn Post-ignition time
- tv2 Delay time to oil V2

### BLOCK DIAGRAM DKO 970/972

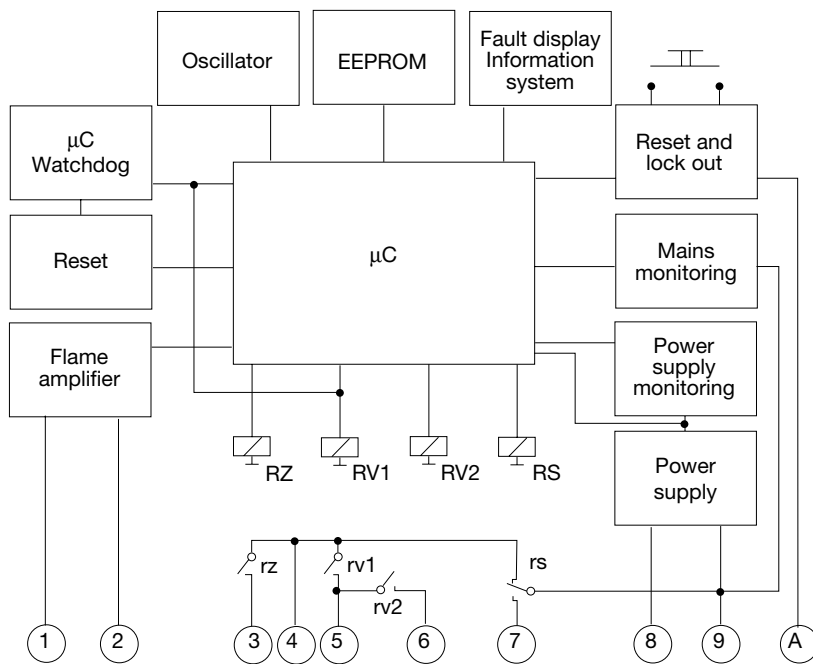

DKO 970/972

### DKO 970/972 AND SOCKET

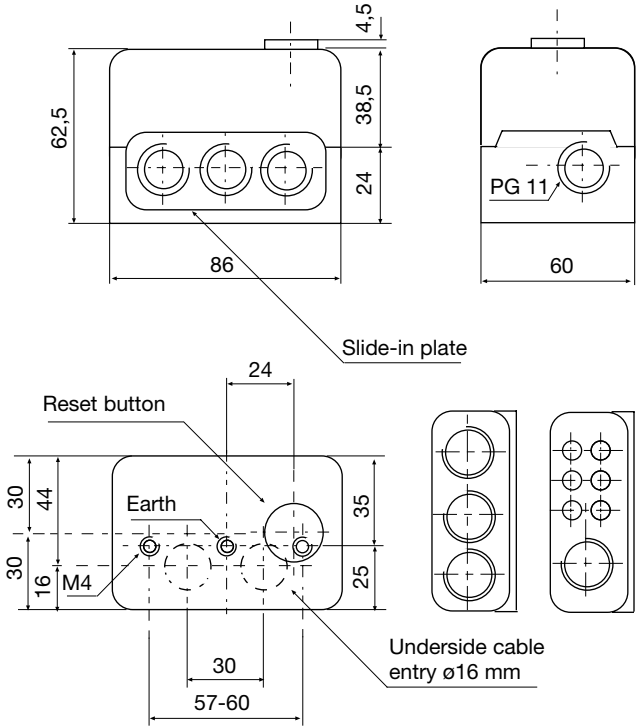

### HOLDER FOR MZ 770 S

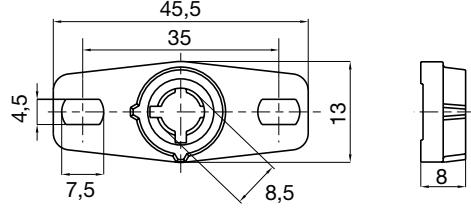

### SHAFT MZ 770 S

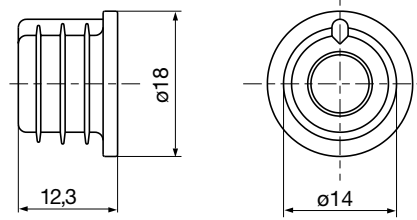

### PHOTORESISTOR MZ 770 S

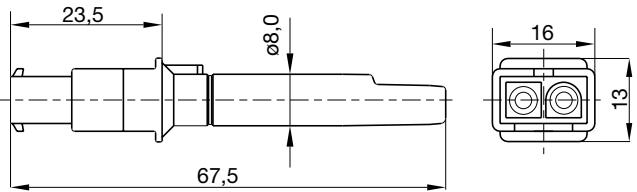

### UVD 970

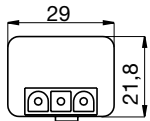

### IRD 1010

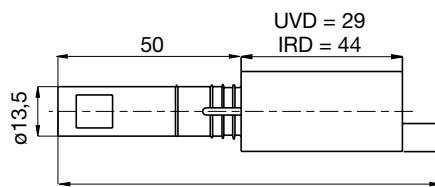
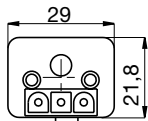

### HOLDER M74 FOR IRD OR UVD

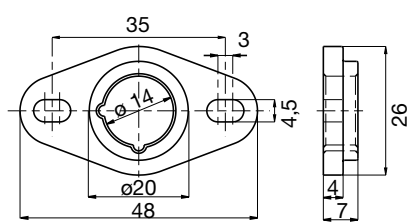

### VARIATION IRD

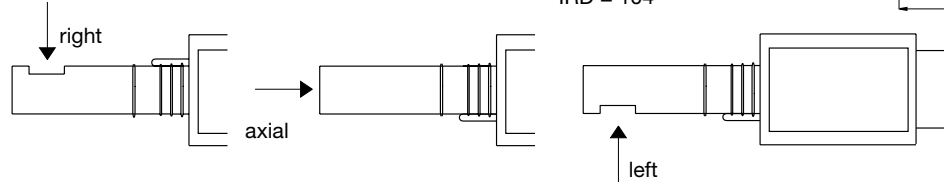

### ORDERING INFORMATION

ITEM	DESIGNATION	ITEM NO.
Control box	DKO 970 Mod. 05	0310005
or	DKO 972 Mod. 05	0312005
Socket	Wiring base S98	75310
Insert plate	PG-Plate	70502
optional	Cable entry plate	70501
Flame detector	MZ 770 S	50001
optional	MZ 770 S with shaft	51001
optional	IRD 1010 right	16501
	IRD 1010 end-on	16502
	IRD 1010 left	16503
optional	UVD 970	16702
Support for flame detector	Holder for MZ 770 S	59101
optional	Holder M 74 for IRD or UVD	59074
Connection cable	Plug type, 3 core cable, 0.6 m with tag wire ends	7236001
Connection cable	Plug type, 2 core cable, 0.5 m with tag wire ends	7225001

The above ordering information refers to the standard version.

Special versions are also included in our product range.

Specifications subject to change without notice

## DKO 970/972

A Honeywell Company

Satronic AG  
Brüelstrasse 7  
Postfach 324  
CH-8157 Dielsdorf

## Oil Burner Safety Control

**For 1- or 2-stage oil burners up to 30 kg/h throughput and intermittent operations with or without oil preheating**

### Flame detection:

- Photoresistor MZ 770 S
- Infrared-flicker detector IRD 1010
- UV flame sensor UVD 970

### INTRODUCTION

The DKO 974/976 oil burner safety control boxes are suitable for oil burners with or without preheater with throughputs up to 30 kg/h. They will be approved and certified according to the applicable European standards and regulations.

The microprocessor-based programming sequence ensures extremely stable timings independent of voltage variations, ambient temperature and/or switch-on cycles. The built-in information system not only provides a continuous monitoring of the actual state of the box (very helpful especially for monitoring the start-up phase) but also informs about the cause of a possible lock out. The lock out cause is stored in such a way that it can be retrieved even after a power failure.

The control box is designed for maximum safety in case of fluctuations in the voltage supply. If the mains voltage drops below the permitted level, operation is interrupted and the control box automatically prevents the start sequence from being repeated. In this way, the safety of the system is not put at risk by a drop in the mains voltage. This low-voltage protection works not only during start-up but also permanently during operation.

### TYPES AVAILABLE

DKO 974	1-stage operation with release thermostat
DKO 976	2-stage operation with release thermostat
DKO 974N	1-stage operation without release thermostat
DKO 976N	2-stage operation without release thermostat

### CONSTRUCTIONAL FEATURES

The control box circuitry is protected by a flame resistant, transparent plug-in type plastic housing. A central fixing screw locks the control box to the wiring base. The plug-in control box incorporates the microprocessor based timer, flame check and reset circuits. Manual reset from lock out and set to lock out is provided by a push button with an integrated lock out signal lamp. The wiring base S98 is equipped with spare- and extraterminals and allows together with a variety of cable entry points utmost flexibility of electrical wiring.

The DKO 974 is compatible with the TF 834, TF 834.2. The DKO 976 is in addition compatible with the TF 804, TF 804.2, TF 836, TF 836.2.



Using the DKO 976 as a replacement for the TF 804 or TF 804.2, the flame sensor FZ 711 S must be replaced by its compatible type MZ 770 S.

### Timings (sec.)

Model	waiting time start	max. warm-up time oil preheater <b>ta</b>	Pre-purge and pre-ignition time <b>tv1</b>	Stray light monitoring <b>tf</b>	safety time <b>ts</b>	Post-ignition time after V1 <b>tn</b>	delay time to V2 DKO 976 only <b>tv2</b>
<b>05</b>	0	400	15	5	5	7	20



### TECHNICAL DATA

Operating voltage	220 / 240 V (-15... +10%) 50 Hz (±5%)
Fuse rating	10 A fast, 6 A slow
Power consumption	ca. 15 VA
Max. load per output	
- term. 3 ignition trafo	1.0 A, cos φ 0.2
- term. 4 motor	2.0 A, cos φ 0.4
- term. 5 + B solenoid valves	0.5 A, cos φ 0.4
- term. 6 oil preheater	2.0 A, cos φ 1.0
- term. 7 alarm indicator	0.5 A, cos φ 0.4
total load	4.0 A, cos φ 0.4 max. 6 A during 0.5 sec
Reset time from lock out	none
Flame detectors	< 3 m length of cable side-on and end-on viewing better 6 Lux side-on or end-on viewing end-on viewing
MZ 770 S	190 g
Light sensitivity	any
IRD 1010	IP 40
UVD 970	
Weight incl. Wiring base	
Mounting position	
Protection class	
Approved ambient parameter for control and flame detector	max. 95% bei 30° C
- for operation	0° C... +60° C
- for storage	-20° C... +80° C
Build-up of ice, penetration of water and condensing water are	inadmissible
Approvals according to European standards	EN 230, as well as all other relevant Directives and standards

## APPLICATION FEATURES

### 1. Information system

The information system is microprocessor based and reports on all aspects of burner control box operation and flame supervision. It informs continuously about the actual programming sequence the unit is just performing. Besides monitoring of the programming sequence it also allows to identify errors during start-up of operation without any additional testing devices. The automatically performed diagnoses is a valuable tool which facilitates service/maintenance work and therefore saves costs. The analyses of the error cause can be done directly on stage or if not possible afterwards as the lock out reason is stored in a non-volatile lock out mode memory.

The information system communicates with the outside world using a LED (the used Flash-Code is similar to the Morse-Code). The messages are optically transmitted by flashing appropriately a LED. Using an (optional) additional terminal the messages can be recorded and displayed in easy readable form.

#### 1.1 Programming sequence display

The built-in microprocessor controls not only the programming sequence but the information system too. The individual phases of the programming sequence are displayed as Flash-Code.

The following messages can be distinguished:

Message	Flash-Code
waiting for control thermostat	.
pre-ignition tv1	.
safety time ts post ignition tn	■   .
delay 2nd stage tv2	■     .
running	_
low mains voltage	■ ■ _

#### Description

| = short pulse

■ = long pulse

. = short pause

\_ = long pause

### 1.2 Lock-out diagnoses

In case of a failure the LED is permanently illuminated. Every 10 seconds the illumination is interrupted by a flash code, which indicates the cause of the error. Therefore the following sequence is performed which is repeated as long as the unit is not reset.

Sequence:

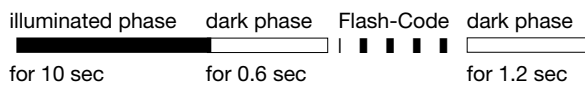

#### Error diagnosis

Error message	Flash-Code	Possible fault
lock out	■ ■ ■ ■	within lock out safety time no flame establishment
stray light	■ ■ ■	stray light during monitored phase, detector may be faulty
limit thermostat time-out	■ ■	contact of limit thermostat does not close within 400 sec.

#### Flash-Code for manual lock out

manual/external lock out	■ ■ ■ _ ■ ■ ■ ■ ■
--------------------------	-------------------

(see also 4. lock out and reset)

## 2. Flame control

The following detectors can be used for flame supervision:

- for yellow oil flame: photoresistor MZ 770 S
- for blue or yellow flame: infrared-flicker detector type IRD 1010 or as an alternative the UV solid state flame sensor UVD 970

Generally, the no flame signal is generated at light levels below 3 Lux with respect to the operating cycle of the control. According to EN 230 stray light safety level has to be established in conjunction with the accompanying burner. Connecting the IRD 1010 or UVD 970, the correct wiring has to be observed.

### 2.1 Stray light monitoring

The stray light check is performed at the end of the pre-purge time for the duration as mentioned in the technical datas.

### 3. Burner control

#### With oil preheater

The fuel heater of the burner has to have a temperature control switch. The closing contact-switch of the heater has to be connected between terminals 4 and 6. A special contact in the control unit connects the thermo-switch of the heater as soon as the burner is operating and a photocurrent is generated. Therefore an interruption of the burner operation due to a decrease in oil temperature is prevented (e.g. in case of high oil flow).

According to EN 230 A 2.1, the short circuiting of the thermostat is allowed only for an oil flow of max. 10 kg/h oil. Burners with a higher throughput have to shut down if the oil temperature gets below the allowed minimum. In such a case the thermo-switch has to be put in the phase-circuit and terminals 4 and 6 have to be connected with a link.

The contact of the release thermostat of the oil preheater is monitored. If the contact does not close within the pre-defined time (400 sec), the programmer goes into lock out mode.

Therefore excessive oil temperatures in the preheater over long periods can be prevented avoiding cracking of the oil and subsequent blocking of the preheater or nozzle.

#### Without oil preheater

In such a case the terminals 4 and 6 have to be connected with a link.



#### Attention

The switch of the release thermostat for the oil preheater must never be linked between 4 and 6 or 6 and 9!

During lockout, the preheater will not be separated from power. This could lead to a defective pre-heater due to burn out its heating winding.

### 4. Lock out and reset

The unit can be reset or brought into lock out mode in two different ways:

#### Internal

In the lock out case the unit can be reset by pushing the built-in button meaning a new start-up cycle is performed.

#### External

Instead of using the built-in lock out button the same function can be achieved by using an external button which connects terminal 9 with A (see also circuit and block diagram).

If the pushbutton (internal or external) is pressed during normal operation or during the start sequence for more than 3 sec. and afterwards released, the control box will perform a shutdown.



#### Please note

The unit can only be brought to lockout mode or be reset if power is applied to the unit.

### 5. Low-voltage protection

The mains voltage has to be more than  $187 V_{eff}$  in order to allow the unit to perform a start-up.

The mains voltage is not only monitored in the start-up phase but also permanently during operation. If the voltage drops below  $< 160 V_{eff}$  during start-up or run time the control box goes into lock out mode. If the voltage rises again, the control box performs automatically a start-up as soon as the mains voltage is  $> 187 V_{eff}$ .

### 6. Safety

The design and control sequence of the DKO 974/976 controls will comply with the currently applicable standards and regulations (see also TECHNICAL DATA).

### 7. Mounting and electrical wiring

#### Wiring base:

- 3 earth terminals with additional terminal for burner earthing
- 3 neutral terminals with internal permanent connection to neutral terminal 8
- 2 independent spare terminals (S1 and S2)
- extra terminals A, B and C are standard
- 2 slide-in plates and 2 easy knock out holes (PG11 thread) plus 2 knock out holes in the base bottom facilitate the base wiring

The digital controls are ideally wired on the new wiring bases S98, which are equipped with (terminals B and C are only for some special types of DMO or DMG) terminal A, which is used for the remote reset / remote lockout functions.



#### Please note

To assist trouble-free operation the main neutral connection terminal in the wiring base must be fully tightened. The terminal screws are already in the undone position. To connect a wire to the terminal, the screw only needs to be fastened.

General: The control box and detector probes should not be subjected to excessive vibration.

## INSTALLATION INSTRUCTIONS AND MAINTENANCE

### 1. Important notes

- The controls must be installed by qualified personnel only. The relevant national regulations have to be observed.
- On commissioning the wiring has to be carefully checked according to the appropriate diagram. Incorrect wiring can damage the unit and endanger the installation.
- The fuse rating has to ensure that the limits specified in TECHNICAL DATA will not be exceeded. If these precautions are not observed, the effect of a short circuit can cause severe damage to the control and installation.
- For safety reasons a minimum of one control shutdown per 24 hours has to be observed.
- Disconnect the mains before the control box is plugged in or out.
- The control box is a safety device and must not be opened!

### 2. Function control

For safety reasons the flame detection system should be tested on commissioning the installation as well as after a service or longer shut-down.

- Start-up with covered flame detector
  - After lock out safety time is over the unit has to go into lock out mode!
- Start-up with exposed flame detector
  - After 12 sec prepurge time the unit has to go into lock out mode!
- Normal start-up with burner in the normal position, cover up the flame detector
  - After start-up, and end of lock out safety time the unit has to go into lock out mode!

### 3. Fault finding

The built-in information system facilitates the trouble shooting in the case of problems occurring during start-up or during operation.

A list of possible lock out messages can be found in APPLICATION FEATURES chapter 1.2.

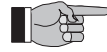

#### Please note:

**The control box is locked in lock out mode and the reason for the lock out is displayed until the control box is reset, either by an internal or external reset (see also subject "3. Lock out and reset").**

Removing the control box from its wiring base or by interrupting the supply line may not reset a lock out (according to EN 230). Therefore, by applying power, the fan motor/nozzle preheater switches on for 2-3 secs. before the control box goes to lock out again and the cause of the last lock out.

Error	Possible fault
Burner not working	- Thermostat circuit open - Faulty electrical wiring - Oil preheater defective - mains voltage < 187 V
Fan motor/nozzle preheater starts for a short period of time, control box goes to lock out	- Control box has not been reset
Burner starts, flame not established, lock out	- Stray light on flame detector - No ignition or no fuel
Burner starts, flame established, after safety time, lock out	- Dirty or faulty flame detector - Insufficient light on detector - Sensitivity adjustment too low on IRD

**CIRCUIT AND TIMING DIAGRAM DKO 974**

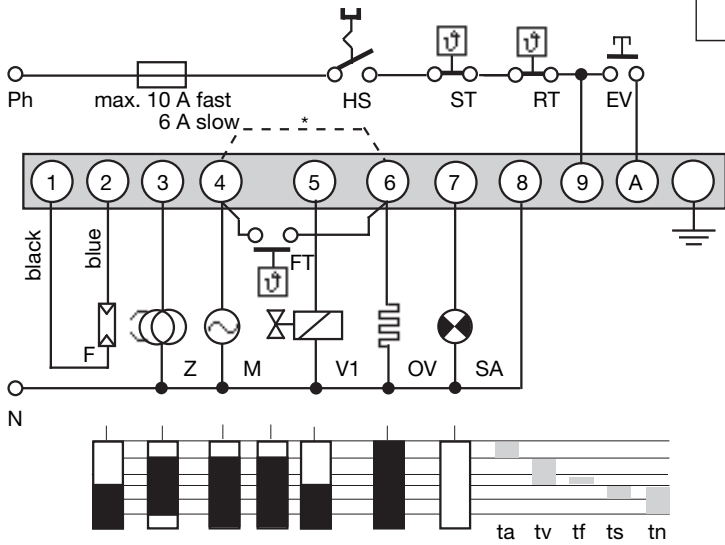

**IRD-/UVD-CONNECTION**

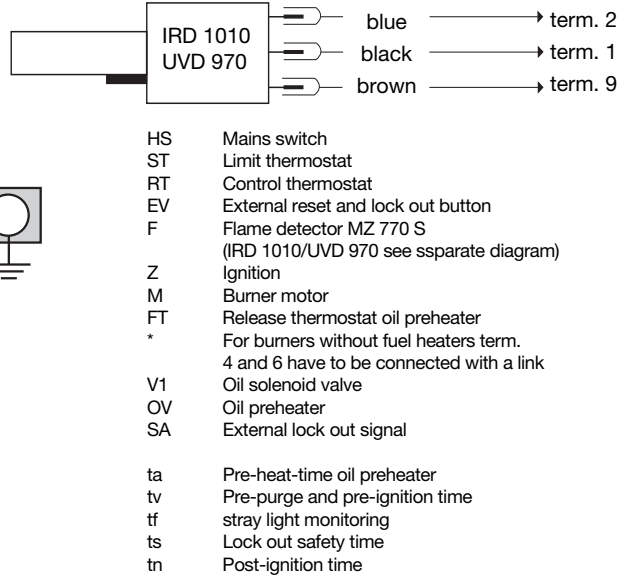

**CIRCUIT AND TIMING DIAGRAM DKO 976**

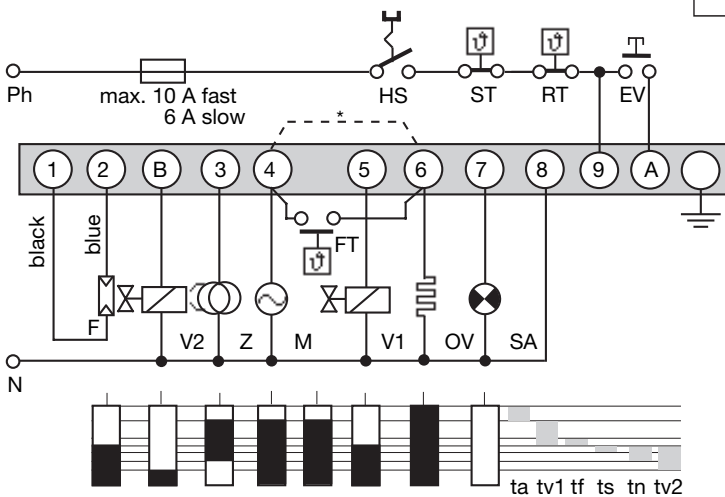

**IRD-/UVD-CONNECTION**

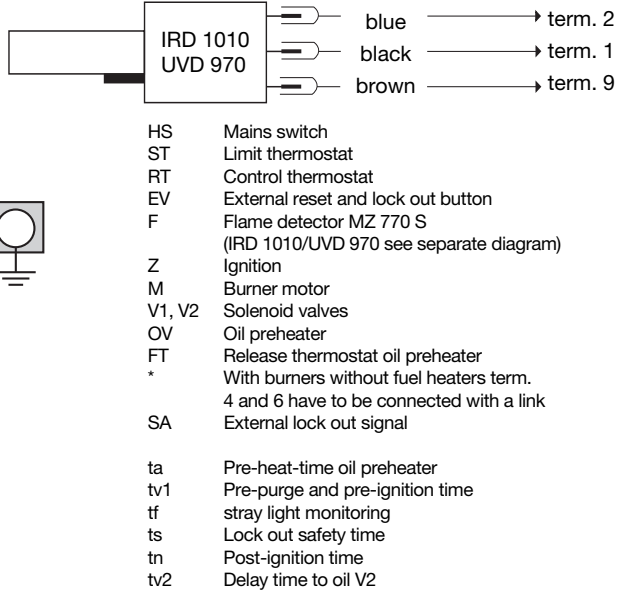

**BLOCK DIAGRAM DKO 974/976**

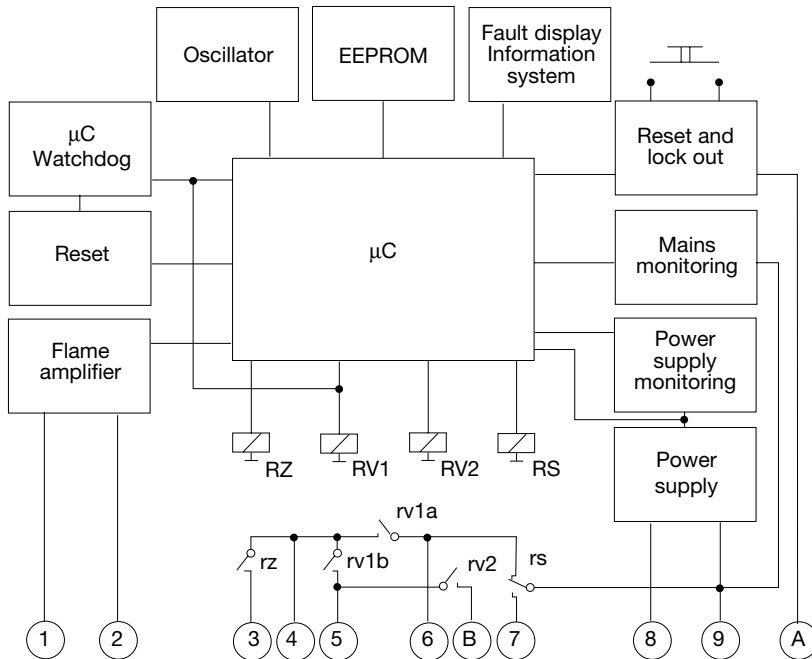

**BLOCK DIAGRAM DKO 974/976**

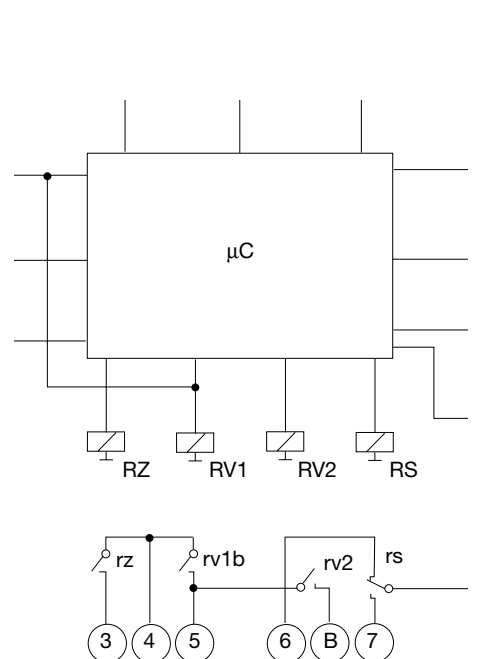

### DKO 974/976 AND SOCKET

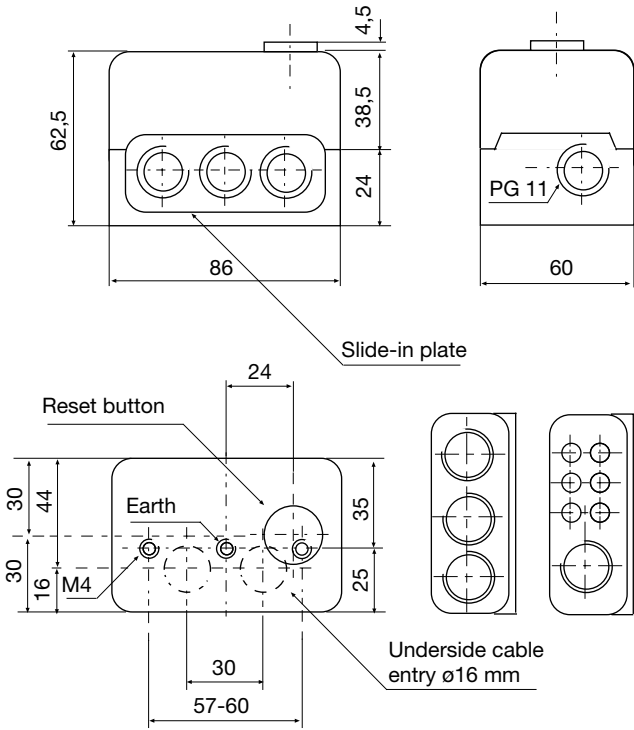

### HOLDER FOR MZ 770 S

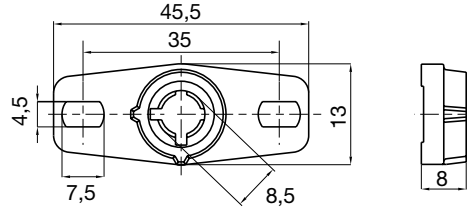

### SHAFT MZ 770 S

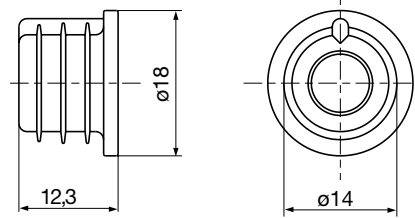

### PHOTORESISTOR MZ 770 S

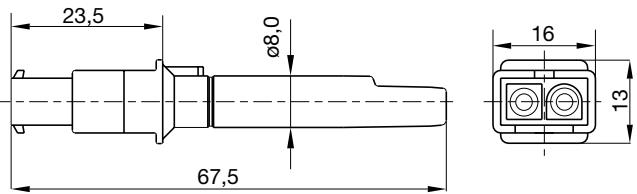

### UVD 970

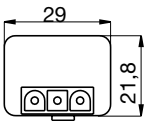

### IRD 1010

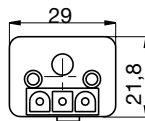

### UVD = 29

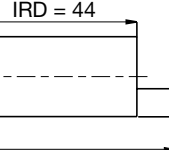

### IRD = 44

### UVD = 89

### IRD = 104

### HOLDER M74 FOR IRD OR UVD

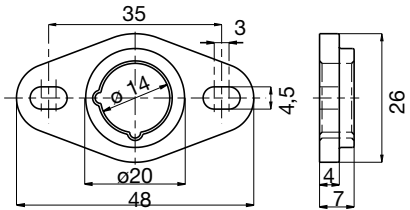

### VARIATION IRD

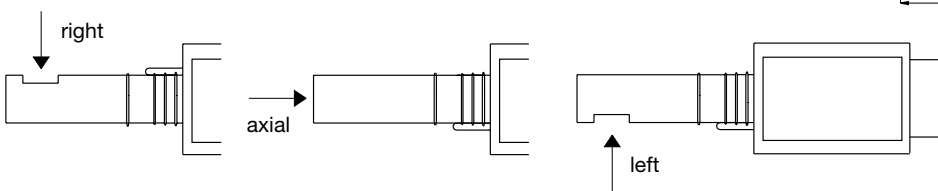

### ORDERING INFORMATION

ITEM	DESIGNATION	ITEM NO.
Control box	DKO 974 Mod. 05	0314005
or	DKO 976 Mod. 05	0316005
or	DKO 974 N Mod. 05	0314705
or	DKO 976 N Mod. 05	0316705
Socket	Wiring base S98	75310
Insert plate	PG-Plate	70502
optional	Cable entry plate	70501
Flame detector	MZ 770 S	50001
optional	MZ 770 S with shaft	51001
optional	IRD 1010 right	16501
	IRD 1010 end-on	16502
	IRD 1010 left	16503
optional	UVD 970	16702
Support for flame detector	Holder for MZ 770 S	59101
optional	Holder M 74 for IRD or UVD	59074
Connection cable	Plug type, 3 core cable, 0.6 m with tag wire ends	7236001
Connection cable	Plug type, 2 core cable, 0.5 m with tag wire ends	7225001

The above ordering information refers to the standard version.

Special versions are also included in our product range.

Specifications subject to change without notice

**DKO 974/976**  
**DKO 974 N/976 N**

**satronic**  
A Honeywell Company

Satronic AG  
Brüelstrasse 7  
Postfach 324  
CH-8157 Dielsdorf

## Oil burner safety control

**For burners on hot-air heaters, as well as burners above 30 kg/h in intermittent operation, 1- or 2-stage.**

**Flame detectors:**

- Photoresistor MZ 770 S
- Flicker detector IRD 911 / 1010

### INTRDUCTION

The oil burner automatic safety control TTO 872, resp., TTO 876 controls and monitors burners on hot air heaters, as well as burners with an oil consumption of over 30 kg/h (approved and certificated acc. to DIN 4787).

If the infrared flicker detector IRD 911 or 1010 is utilized as flame monitor, even red hot combustion chamber walls cannot affect the safe operation, since this sensor exclusively responds to the flame.

The oil burner automatic safety control TTO 876 is fully interchangeable with the type TTO 836. The automatic control TTO 872 is – with the exception of the flame detector – compatible with type TTO 810. When replacing type TTO 810, the photo-cell FZ 711 has also got to be replaced by an MZ 770 S.

The different heights are compensated for by mounting the pushbutton extension (art. No. 70601).

Instead of the pushbutton extension, it is also possible to mount the remote reset device FR 870 (art. No. 70700, refer to the documentation "Remote Reset device FR 870").

The oil burner control boxes TTO 872.2 / 876.2 are equipped with a low-voltage protection according to DIN-EN 230.

### TYPES AVAILABLE

TTO 872.2 without connecting terminal for oil pre-heater  
 TTO 876.2 with bridging contact and connection for oil pre-heater.

### CONSTRUCTIONAL FEATURES

The automatic control is housed in a non-inflammable, transparent, plug-in type plastic case and contains the thermo-mechanical and electronic combined time element, the flame monitor part and the reset device.

On the top of the unit there are the illuminated pushbutton for indication of malfunctions and reset, as well as the screw for central mounting.

The base can be equipped with additional loop terminals and – together with the various possibilities for cable entry – enables a universal wiring.



### TECHNICAL DATA

Operating voltage	220 / 240 V (-15... +10%) 50 Hz (40 - 60 Hz)
Rating fuse	max. 10 A rapid, 6 A slow
Power consumption	approx. 5 VA
Max. load per output valve outputs total	4 A ohmic (resistive) 2 A ohmic (resistive) 6 A ohmic (resistive)
Pre-purge time	20 sec
Pre-ignition time	20 sec
Post-ignition time	2 - 4 sec
Delay time valve 2	approx. 40 sec
Ignition safety time	5 sec max.
Waiting period after shut-down due to malfunction	approx. 60 sec
Flame detector	
MZ 770 S	for side-on and end-on viewing
IRD 911 / 1010	for side-on and end-on viewing
Light sensitivity MZ 770 S	better than 8 Lux
Detector current during operation	min. 48 µA
Connection to flame detector	
MZ 770 S	2 m cable length maximum
IRD 911 / 1010	up to 100 m cable length
Weight, incl. base	0.25 kg
Mounting position	Any
Insulation Standard	IP 44
Recommended ambient operating temperatur for control and flame detector	-20° C... +60° C

## APPLICATION NOTES

### 1. Flame control

The following flame detectors can be used for flame control:

- For yellow oil flame: photoresistor MZ 710 S (side-on or end-on viewing).
- For blue or yellow oil flame: infrared-flame detector type IRD 1010.

Generally the no flamesignal is generated at light levels belw 3 Lux with respect to the operating cycle of the control. According to DIN 4787, clause 4.3.4, stray light safety level has to be established in conjunction with the accompanying burner.

By installing the IRD/TTO adaptor cable between the IRD 1010 and the detector cable in conjunction with the TTO 872 or TTO 876 control boxes, the uniform system of baseplate wiring can be adhered to.

### 2. Burner Control

A special contact in the unit (only TTO 876) bridges the release thermostat of the oil pre-heater as soon as the burner goes into operation and a photocurrent is present. This prevents an interruption to the operating sequence as a result of declining oil temperature (e.g., high throughput capacity). In accordance with DIN 4787, part 1, section 4.2.6, the internal bridging of the release thermostat of the oil pre-heater is only permissible up to a throughput capacity of maximum 10 kg/h of oil. Burners with higher capacities have to switch off when the required oil temperature is not reached. The release thermostat must then be installed in the phase supply line and terminal 4 bridged with 6.

### 3. Safety

With respect to design and programme sequence, the oil burner automatic safety controls type TTO 872 and TTO 876 comply with the currently applicable European standards and regulations for hot air heaters and burners with capacities of over 30 kg/h.

### 4. Mounting and Electrical Installation

Wiring base:

- 3 earth terminals with additional terminal for burner earthing.
- 3 neutral terminals with internal permanent connection to neutral terminal.
- 2 slide-in plates and 2 easy-knock out holes (PG 11 thread), plus 2 knock out holes in the base bottom facilitate the base wiring.
- For 2-stage burners, which are equipped with the TTO 876, the unit base type 701-TTG-EN (Art. No. 70101) or type 701-TTG-ENCD (Art. No. 70103) have to be used.

General:

- Mounting position optional, protection class IP 44 (water spray). Control box and flame detector should not be subjected to excessive vibration.
- When installing the control, the relevant regulations have to be observed.

## COMMISSIONING AND ROUTINE CHECKS

### 1. Important notes

- On commissioning it is advisable to carefully check the wiring according to the appropriate diagram. Incorrect wiring can damage the unit and endanger the installation.
- The fuse rating has to ensure that the limits specified in Technical Data will not be exceeded. If these precautions are not observed, the effect of a short circuit can cause severe damage to the control and installation.
- For safety reasons a minimum of one control shut-down per 24 hours has to be ensured.
- Disconnect the mains before the control box is plugged in or out.
- The control box is a safety device and must not be opened.

### 2. Functional control

For safety reasons the flame detection system should be tested on commissioning the installation as well as after a service or a longer shut-down.

- a) Start-up with covered flame detector:
  - After lock-out safety time
  - > lockout
- b) Start-up with exposed flame detector:
  - After ca. 20 sec. pre-purge:
  - > lockout
- c) Normal start-up; with burner in the "run" position, cover up the flame detector:
  - New start-up, after end of lock-out safety time
  - > lockout

For safety reasons, the darkening of the flame detector must only take place at the earliest after 1 minute of operation.

### 3. Fault finding

Burner not working:

- Faulty electrical wiring, thermostat circuit open
- Oil preheater defect

Burner starts, flame not established = lockout

- Stray light on flame detector.
- No ignition or no fuel.

Burner starts, flame established, after safety time = lockout:

- Flame detector dirty or faulty
- Insufficient light on detector
- Sensitivity adjustment too low on IRD

**CIRCUIT AND TIMING DIAGRAM TTO 872.2**

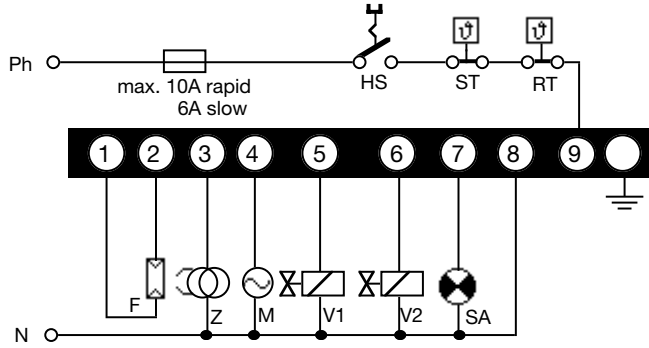

**IRD-SUPPLY**

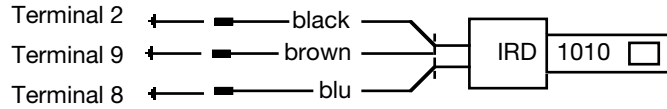

**CIRCUIT AND TIMING DIAGRAM TTO 872.2**

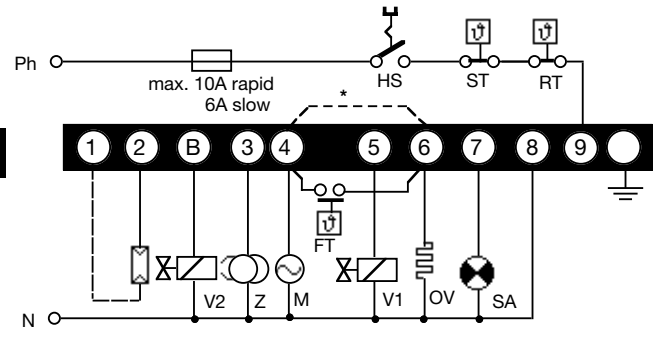

- HS Main switch
- ST Safety thermostat
- RT Controlling thermostat
- F Flame detector MZ 770 S (IRD 1010 in accordance with separate connection diagram)
- Z Ignition
- M Burner motor
- V1 Solenoid valve 1st stage
- V2 Solenoid valve 2nd stage
- FT Release thermostat oil preheater
- OV Oil pre-heater
- SA External indication of malfunction

**SCHEMATIC DIAGRAM TTO 872.2**

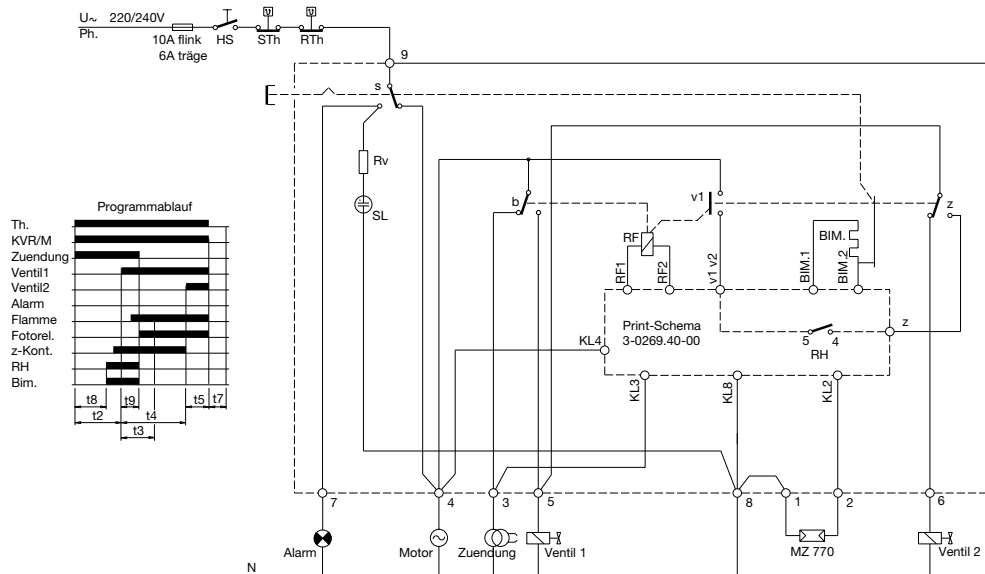

**SCHEMATIC DIAGRAM TTO 876.2**

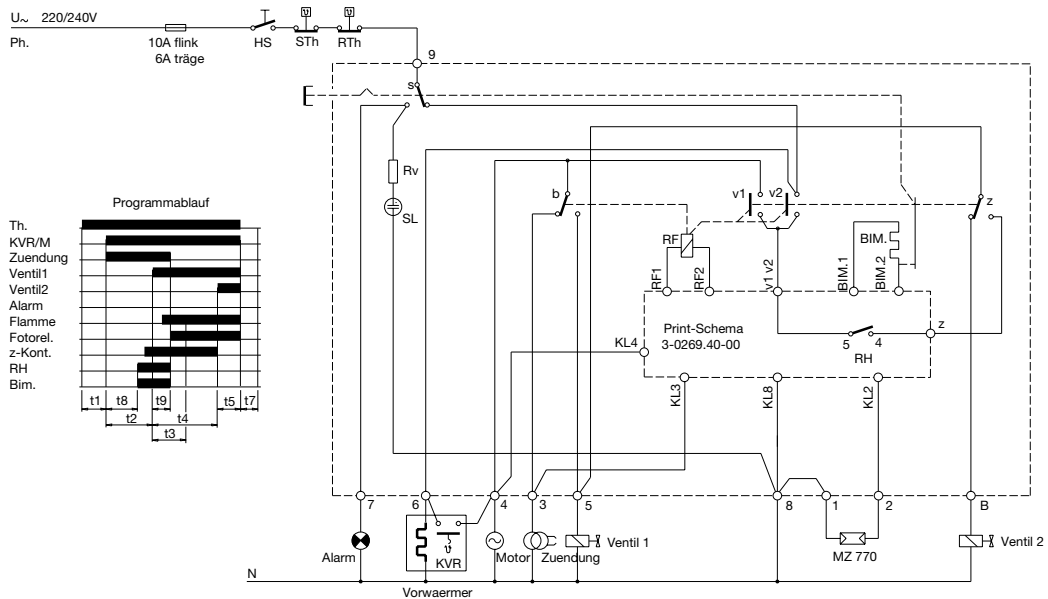

**TTO 872 / 876 WITH BASE**

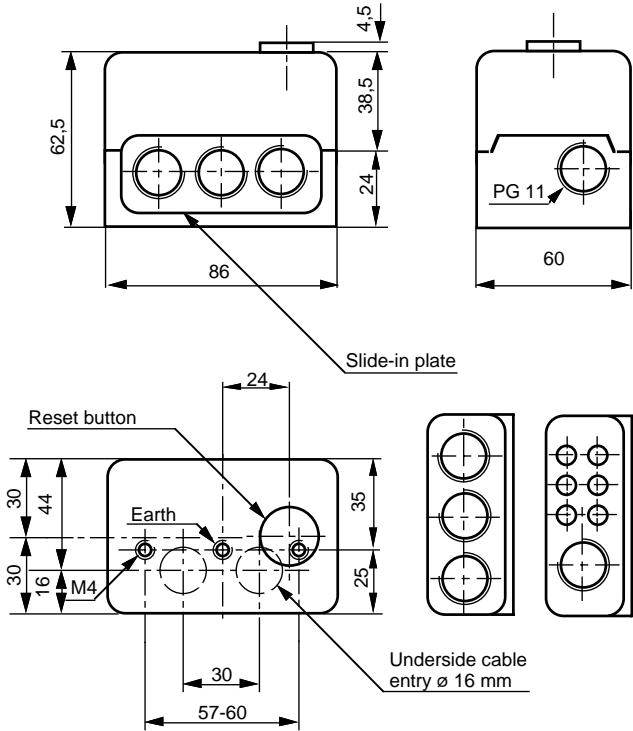

**SUPPORT FOR MZ 770 S**

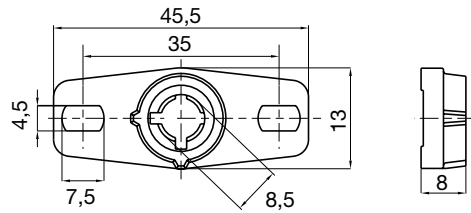

**PLUG-IN SHAFT MZ 770 S**

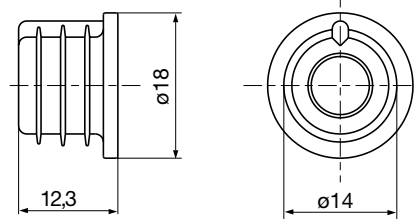

**PHOTORESISTOR MZ 770 S**

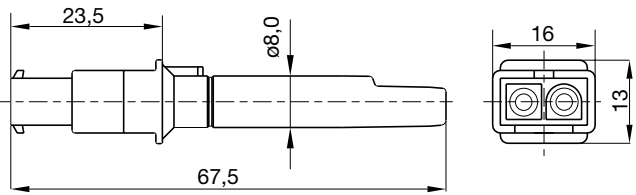

**IRD 1010**

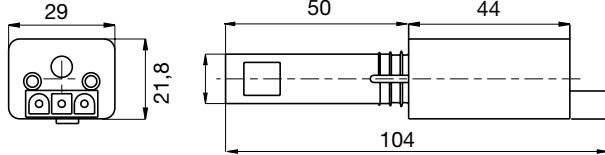

**IRD 911**

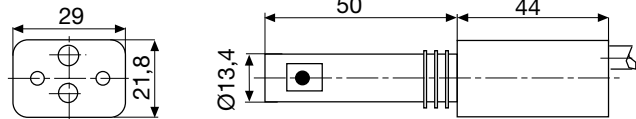

**VARIATION**

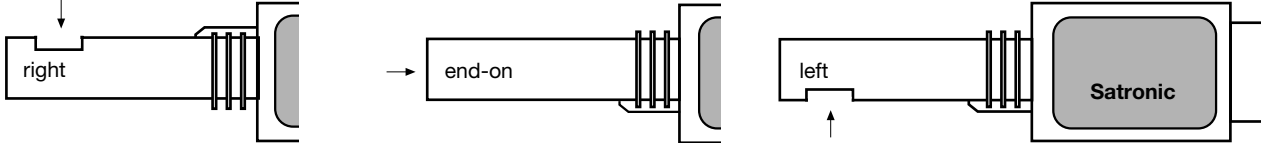

**ORDERING INFORMATION**

ITEM	DESIGNATION	ITEM NO.
Control unit	Type TTO 872.2	02811
or	Type TTO 876.2	02801
Socket	Socket 701 ABEN	70001
Socket for TTO 876, 2-stage	Socket 701 TTG-EN	70101
Insert plate	PG-plate	70502
optionally	Cable entry plate	70501
Flame detector	MZ 770 S	50001
optional	MZ 770 S mounted with plug-in shaft	51001
optional	IRD 1010 right	16501
	IRD 1010 end-on	16502
	IRD 1010 left	16503
Support for flame detector	Holder for MZ	59101
optional	FZ Holder M 74	59074
Connection cable IRD	Plug-type, 3 core cable, 0.6 m, with tag wire ends	7236001
Connection cable MZ	Plug-type, 2 core cable, 0.5 m, with tag wire ends	7225001

The above ordering information refers to the standard version.  
Special versions are also included in our product range.

Specifications subject to change without notice.

**TTO 872 / 876**



A Honeywell Company

Satronic AG  
Brüelstrasse 7  
Postfach 324  
CH-8157 Dielsdorf

## Oil burner safety control

**For burners on hot-air heaters, as well as burners above 30 kg/h in intermittent operation, 1- or 2-stage, direct lockout Flame detectors:**

- Photoresistor MZ 770 S
- Flicker detector IRD 911 / 1010

### INTRODUCTION

The oil burner automatic safety control MMO 872, resp., MMO 876 controls and monitors burners on hot air heaters, as well as burners with an oil consumption of over 30 kg/h (approved and certificated acc. to EN 230).

If the infrared flicker detector IRD 911 or 1010 is utilized as flame monitor, even red hot combustion chamber walls cannot affect the safe operation, since this sensor exclusively responds to the flame.

The oil burner automatic safety control MMO 872/876 is fully interchangeable with the type TTO 872/876, but going directly to lockout (=lockout at loss of flame).

It is possible to mount the remote reset device FR 870 (art. No. 70700, refer to the documentation "Remote Reset device FR 870").

The oil burner control boxes MMO 872/876 are equipped with a low-voltage protection according to DIN-EN 230.

### TYPES AVAILABLE

MMO 872 without connecting terminal for oil pre-heater  
 MMO 876 with bridging contact and connection for oil pre-heater.

### CONSTRUCTIONAL FEATURES

The control box is enclosed in a protective, flame resistant, transparent, plug-in type plastic housing, and includes:

- Synchronous motor with reduction gearing driving cam switch
- Cam switch with informative, coloured programme indicator
- 10-way cam switch assembly controlling the programme sequence
- Electronic components on plug-in printed circuit

The following important indicators and operating controls are situated on the front of the control box:

- Reset button incorporating signal lamp for malfunction (lockout)
- Coloured programme indicator
- Central screw fastening



### TECHNICAL DATA

Operating voltage	220 / 240 V (-15... +10%) 50 Hz (40 - 60 Hz)
AC frequency variations	result in proportional timing deviations
Rating fuse	max. 10 A rapid, 6 A slow
Power consumption	approx. 10 VA
Max. load per output	
- Kl. 3, ign. trafo	2 A, cos $\varphi$ 0.2
- Kl. 4, fan motor	2 A, cos $\varphi$ 0.4
- Kl. 5 + 6 + B, solenoid valves	1 A, cos $\varphi$ 0.4
- Kl. 6, oil preheater	2 A, cos $\varphi$ 1
- Kl. 7, alarm indicator	2 A, cos $\varphi$ 0.4
total load	5 A, cos $\varphi$ 0.4
Pre-purge time	23.5 sec
Pre-ignition time	23.5 sec
Post-ignition time	8.5 sec
Delay time valve 2	40 sec
Ignition safety time	5 sec max.
Waiting period after shut-down due to malfunction	none
Flame detector	
MZ 770 S	for side-on and end-on viewi.
IRD 911 / 1010	for side-on and end-on viewi.
Light sensitivity MZ 770 S	better than 8 Lux
Connection to flame detector	
MZ 770 S	2 m cable length maximum
IRD 911 / 1010	up to 100 m cable length
Weight, incl. base	0.35 kg
Mounting position	Any
Insulation Standard	IP 44
Recommended ambient operating temperatur for control and flame detector	-20° C... +60° C

## APPLICATION NOTES

### 1. Flame control

The following flame detectors can be used for flame control:

- For yellow oil flame: photoresistor MZ 710 S (side-on or end-on viewing).
- For blue or yellow oil flame: infrared-flame detector type IRD 1010.

Generally the no flamesignal is generated at light levels below 3 Lux with respect to the operating cycle of the control. According to DIN 4787, clause 4.3.4, stray light safety level has to be established in conjunction with the accompanying burner.

Commissioning with MZ 770 S: Measuring the photo-current is unreliable, as the value does not change remarkably. It is recommended to measure the DC-voltage between terminals 1/- and 2/+.

voltage during pre-purge: > 55 VDC

voltage during operation: < 25 VDC

Input impedance of the voltmeter:  $\geq 10 \text{ M}\Omega$

By installing the IRD/TTO adaptor cable between the IRD 1010 and the detector cable in conjunction with the MMO 872 or MMO 876 control boxes, the uniform system of baseplate wiring can be adhered to.

### 2. Burner Control

A special contact in the unit (only MMO 876) bridges the release thermostat of the oil pre-heater as soon as the burner goes into operation and a photocurrent is present. This prevents an interruption to the operating sequence as a result of declining oil temperature (e.g., high throughput capacity). In accordance with DIN 4787, part 1, section 4.2.6, the internal bridging of the release thermostat of the oil pre-heater is only permissible up to a throughput capacity of maximum 10 kg/h of oil. Burners with higher capacities have to switch off when the required oil temperature is not reached. The release thermostat must then be installed in the phase supply line and terminal 4 bridged with 6.

### 3. Safety

With respect to design and programme sequence, the oil burner automatic safety controls type MMO 872 and MMO 876 comply with the currently applicable European standards and regulations for hot air heaters and burners with capacities of over 30 kg/h. Features, which increase the safety above the standard:

- flame supervision with infrared-detector
- direct lockout

### 4. Mounting and Electrical Installation

Wiring base:

- 3 earth terminals with additional terminal for burner earthing.
- 3 neutral terminals with internal permanent connection to neutral terminal.
- 2 slide-in plates and 2 easy-knock out holes (PG 11 thread), plus 2 knock out holes in the base bottom facilitate the base wiring.
- For 2-stage burners, which are equipped with the TTO 876, the unit base type 701-TTG-EN (Art. No. 70101) or type 701-TTG-ENCD (Art. No. 70103) have to be used.

General:

- Mounting position optional, protection class IP 44 (water spray). Control box and flame detector should not be subjected to excessive vibration.
- When installing the control, the relevant regulations have to be observed.

## COMMISSIONING AND ROUTINE CHECKS

### 1. Important notes

- On commissioning it is advisable to carefully check the wiring according to the appropriate diagram. Incorrect wiring can damage the unit and endanger the installation.
- The fuse rating has to ensure that the limits specified in Technical Data will not be exceeded. If these precautions are not observed, the effect of a short circuit can cause severe damage to the control and installation.
- For safety reasons a minimum of one control shut-down per 24 hours has to be ensured.
- Disconnect the mains before the control box is plugged in or out.
- The control box is a safety device and must not be opened.

### 2. Functional control

For safety reasons the flame detection system should be tested on commissioning the installation as well as after a service or a longer shut-down.

- 2.1 Start-up with covered flame detector:  
-> lockout at the end of the safety time
- 2.2 Start-up with exposed flame detector:  
-> lockout after start of the fan motor
- 2.3 Normal start-up; with burner in the "run" position, cover up the flame detector:  
-> direct lockout

### 3. Fault finding

- 3.1 Burner does not operate, programme indicator remains stationary:
  - Fault in electrical supply
  - Thermostat OFF
- 3.2 Control box goes to lockout shortly after beginning pre-purge (programme indicator in blue area):
  - no load at terminal 5
  - flame sensor faulty control box faulty
  - Flame signal (stray light)
- 3.3 Control box goes to lockout at the end of the safety delay time (yellow area):
  - IRD sensitivity setting too low
  - flame sensor dirty or incorrectly installed
  - flame sensor incorrectly wired or faulty
  - control box faulty
- 3.4 No flame, lockout at the end of the safety delay time (yellow area):
  - no ignition
  - no fuel supply
- 3.5 lockout at the red area:
  - flame unstable after the end of the safety time
- 3.6 Control box goes to lockout during normal operation (end of green area):
  - Loss of flame
  - Flame signal too weak

Note:

If a control box goes to lockout, it is in most cases doing its function for which it has been designed. Beside the mentioned possibilities, one of the following ones can be the reason for a burner fault:

- ignition spark at the wrong position
- oil tank empty
- oil tap closed
- oil filter stuck
- oil pump faulty

**CIRCUIT AND TIMING DIAGRAM MMO 872**

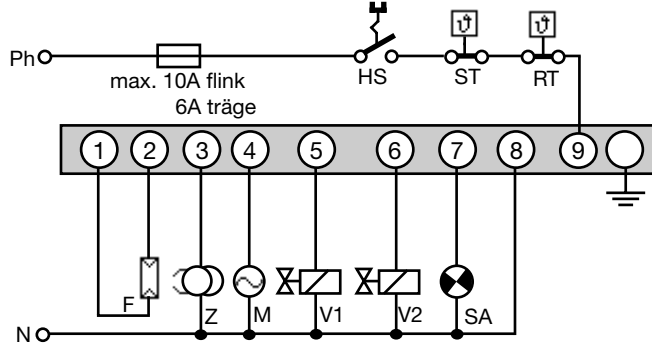

**IRD-SUPPLY**

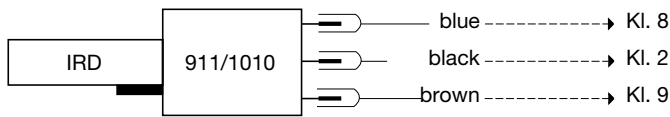

**CIRCUIT AND TIMING DIAGRAM MMO 876**

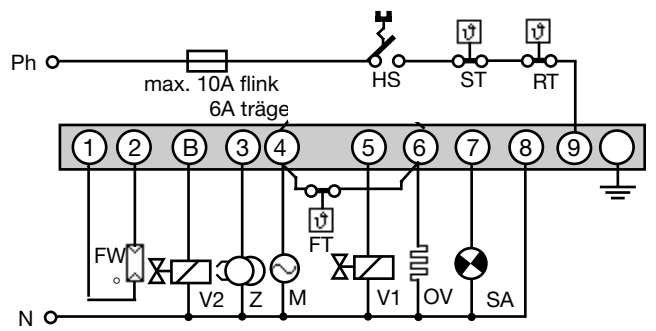

- HS Main switch
- ST Safety thermostat
- RT Controlling thermostat
- F Flame detector MZ 770 S (IRD 1010 in accordance with separate connection diagram)
- Z Ignition
- M Burner motor
- V1 Solenoid valve 1st stage
- V2 Solenoid valve 2nd stage
- FT Release thermostat oil preheater
- OV Oil pre-heater
- SA External indication of malfunction

**SCHEMATIC DIAGRAM MMO 872**

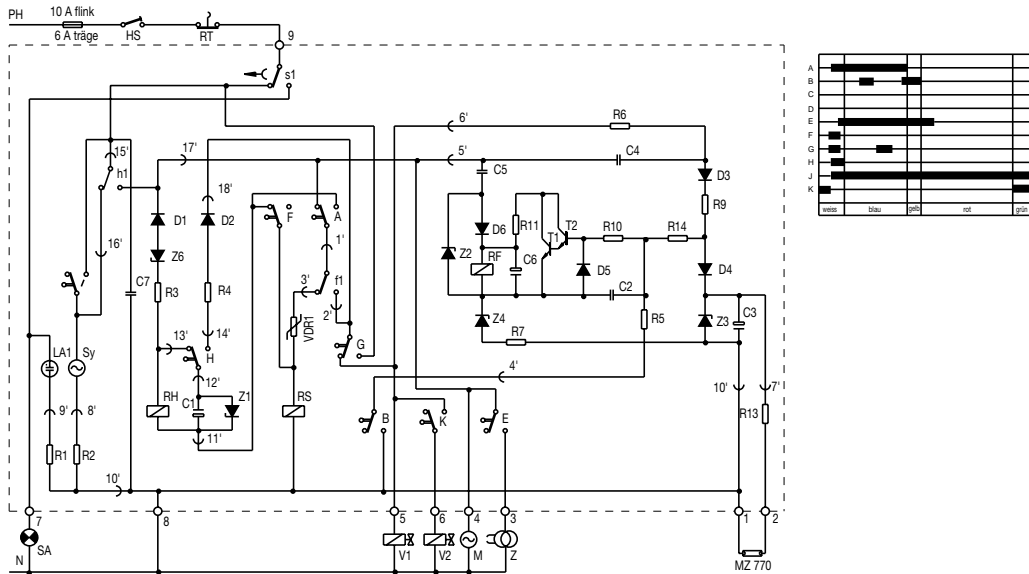

**SCHEMATIC DIAGRAM MMO 876**

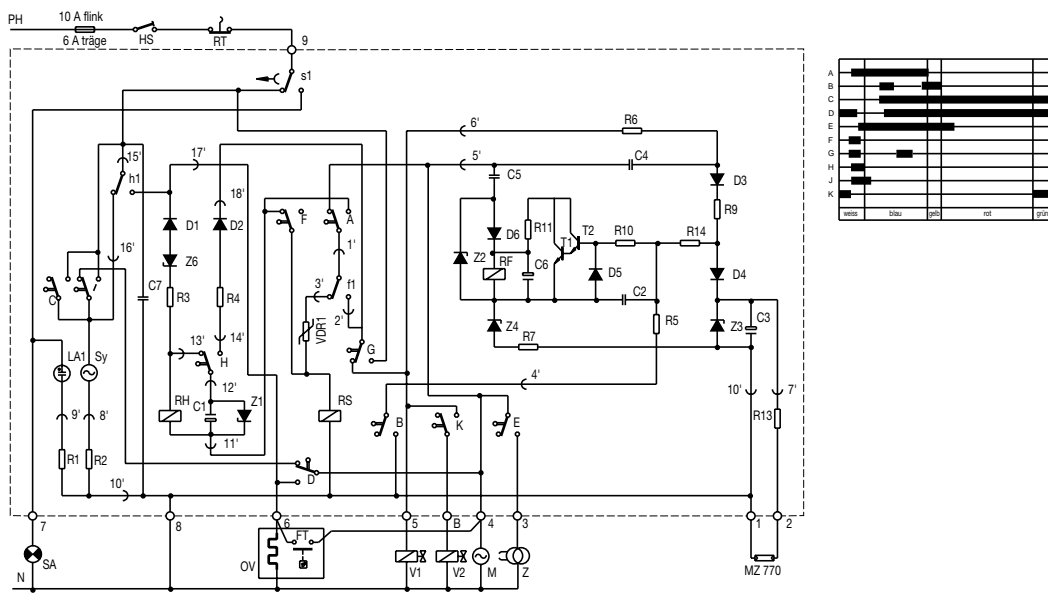

**MMO 872 / 876 WITH BASE**

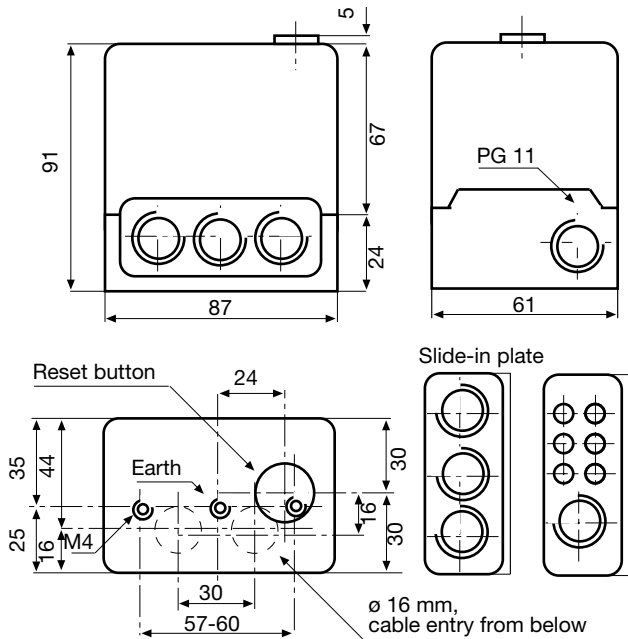

**SUPPORT FOR MZ 770 S**

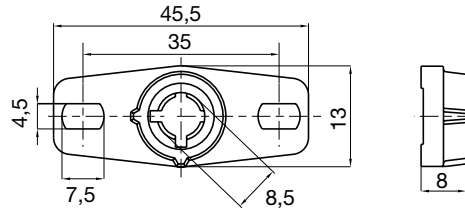

**PLUG-IN SHAFT MZ 770 S**

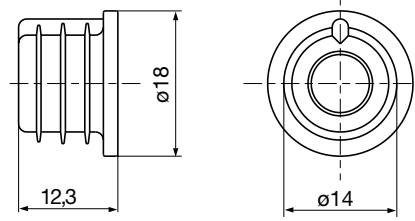

**PHOTORESISTOR MZ 770 S**

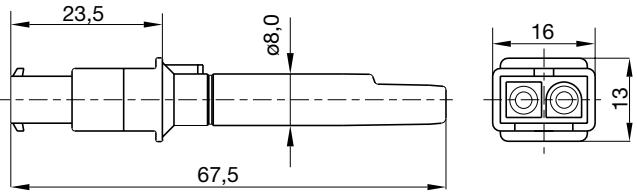

**IRD 1010**

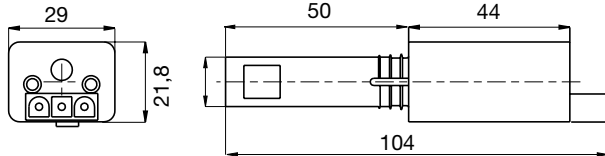

**IRD 911**

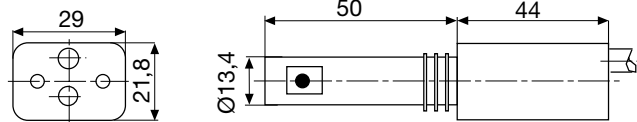

**VARIATION**

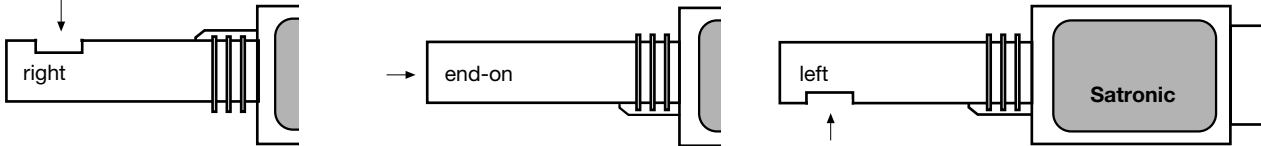

**ORDERING INFORMATION**

ITEM	DESIGNATION	ITEM NO.
Control unit	Type MMO 872	06610
or	Type MMO 876	06611
Socket	Socket 701 ABEN	70001
Socket for TTO 876, 2-stage	Socket 701 TTG-EN	70101
Insert plate	PG-plate	70502
optionally	Cable entry plate	70501
Flame detector	MZ 770 S	50001
optional	MZ 770 S mounted with plug-in shaft	51001
optional	IRD 1010 right	16501
	IRD 1010 end-on	16502
	IRD 1010 left	16503
Support for flame detector	Holder for MZ	59101
optional	FZ Holder M 74	59074
Connection cable IRD	Plug-type, 3 core cable, 0.6 m, with tag wire ends	7236001
Connection cable MZ	Plug-type, 2 core cable, 0.5 m, with tag wire ends	7225001

The above ordering information refers to the standard version.  
Special versions are also included in our product range.

Specifications subject to change without notice.

**MMO 872 / 876**



Satronic AG  
Brüelstrasse 7  
Postfach 324  
CH-8157 Dielsdorf

## Oil burner safety control

**For 2-stage oil burners with a blue flame  
 Flame detector: IRD 1010  
 QRC 1... (LANDIS+GYR)**

### INTRODUCTION

The MMD 900.1 oil burner control box is suitable to control and supervision of oil burners with a blue ish burning flame. For flame detection, the Infrared Flicker Detector IRD 1010 or the blue flame detector QRC 1 is recommended.

The release of valve 2 is delayed in such a way that the mixing zone of the burner is at the right temperature so that the 2nd stage can se properly added.

At flame failures shortly after the safety time, the control box goes to lockout.

### CONSTRUCTIONAL FEATURES

The control box is housed in a tough transparent and self-extinguishing plastic cover. The control incorporates the following features:

- Synchronous motor driving a cam switch assembly
- cam shaft with informative coloured programme indicator
- cam assembly with 10 switches to control the program sequence
- Plug-in printed circuit boards

The following important display - and operating features are located on the front side:

- Illuminated lock-out display and reset button
- Coloured programme indicator
- Central fixing screw



### TECHNICAL DATA

Supply	220 / 240 V (-15... +10%) 50 Hz (40 - 60 Hz)
Supply variations	timings will vary in propor-
frequency	tion to supply
fuse rating	max. 10 A rapid, 6 A slow
Power consumption	10 VA
Max. load per output	
- Kl. 3, ign. trafo	2 A, cos $\varphi$ 0.2
- Kl. 4, fan motor	2 A, cos $\varphi$ 0.4
- Kl. 5 + 6, solenoid valves	1 A, cos $\varphi$ 0.4
- Kl. 7, alarm indicator	2 A, cos $\varphi$ 0.4
total load	5 A, cos $\varphi$ 0.4
Waiting time	8 secs
Pre-purge time	17 secs
Pre-ignition time	17 secs
Ignition safety time	5 secs
Post-ignition time	approx. 20 secs
Delay to 2nd stage V2	52 secs
Reset time from lockout	none
Flame detector:	
- infra-red flicker detector	IRD 1010
length to IRD	cable 10 m max.
- blue flame detector	QRC 1...
length to QRC	cable 1 m max.
Weight, control box and base	0.35 kg
Mounting attitude	any
Insulation Standard	IP 44
Recommended ambient	
operating temperature	
for control and flame detector	-20° C... +60° C

## FEATURES

### 1. Flame detection

Flame is detected by means of an infra-red flicker detector, the IRD 1010. The IRD 1010 is designed to respond only to a pulsating infra-red signal, i.e. the oil burner flame, and not the steady glow of the ceramic combustion chamber.

### 2. Burner control box

If flame is established but a fault occurs within 5 seconds of the expiry of the ignition safety time, the control box will again go to lock-out. Any loss of flame occurring beyond this stage of the light-up sequence, the control box will shutdown, return to the start position and attempt to relight.

### 3. Safety

The MMD 900 control box complies with the relevant oil burner standards. In addition to the basic safety requirements, the control box has the following features:

- Flame detection with an infra-red flicker detector
- Short ignition safety time (5 secs.)
- Direct lockout during start-up sequence

### 4. Mounting and electrical wiring

Wiring base:

- 3 earth terminals with additional terminal for burner earthing.
- 3 neutral terminals
- 2 slide-in plates and 2 easy-knockout holes (PG 11 thread), plus 2 easy-knockout holes in the base bottom facilitate the base wiring.

General:

- Mounting position optional, insulation standard IP 44 (water spray). Control box and flame detector should not be subjected to excessive vibration.
- When installing the control, the relevant regulations have to be observed.

## COMMISSIONING AND ROUTINE CHECKS

### 1. Important notes

- On commissioning it is advisable to carefully check the wiring according to the appropriate diagram. Incorrect wiring can damage the unit and endanger the installation.
- The fuse rating has to ensure that the limits specified in Technical Data will not be exceeded. If these precautions are not observed, the effect of a short circuit can cause severe damage to the control and installation.
- For safety reasons a minimum of one control shut-down per 24 hours has to be ensured.
- Disconnect the mains before the control box is plugged in or out.
- The control box is a safety device and must not be opened

### 2. Function control

For safety reasons the flame detection system should be tested on commissioning the installation as well as after a service or a longer shut-down.

- 2.1 Start-up with covered flame detector:
  - After lock-out safety time
  - > lockout
- 2.2 Start-up with exposed flame detector:
  - After ca. 20 sec. pre-purge:
  - > lockout
- 2.3 Normal start-up; with burner in the "run" position, cover up the flame detector:
  - New start-up, after end of lock-out safety time
  - > lockout

### 3. Fault finding

- 3.1 Burner does not start. Coloured programme indicator stopped in white sector:
  - Check power supply
  - Check that thermostat circuits are closed
- 3.2 Lock-out during pre-purge. Coloured programme indicator stopped in blue sector:
  - Check for false flame signal or flame simulation
  - No load at terminal 5
  - Faulty IRD / QRC
  - Faulty control box
- 3.3 Burner lights but control box locks out at the end of the yellow sector:
  - IRD sensitivity set too low
  - IRD / QRC dirty or incorrectly installed
  - IRD / QRC incorrectly wired or faulty
  - Faulty control box
- 3.4 Burner does not light. Control box locks out at the end of the yellow sector:
  - No ignition
  - No oil
- 3.5 Lockout between end of yellow sector and red line in blue sector:
  - Unstable flame after end of ignition safety time

N.B.:

If control box goes to lockout, it is generally performing the function it is designed for. Other possible causes of failure include:

- Ignition spark in wrong position
- No oil
- Oil solenoid valve closed
- Blocked oil filter
- Faulty oil pump

**CIRCUIT AND TIMING DIAGRAM MMD 900.1**

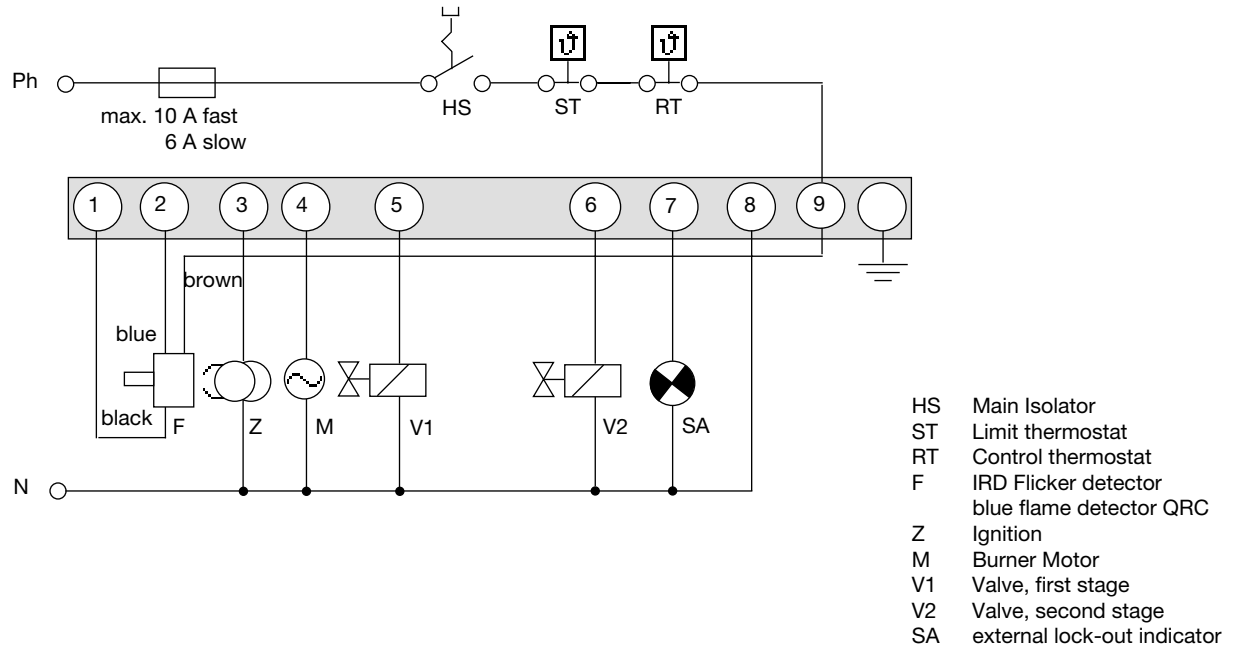

**PROGRAMME SEQUENCE MMD 900.1**

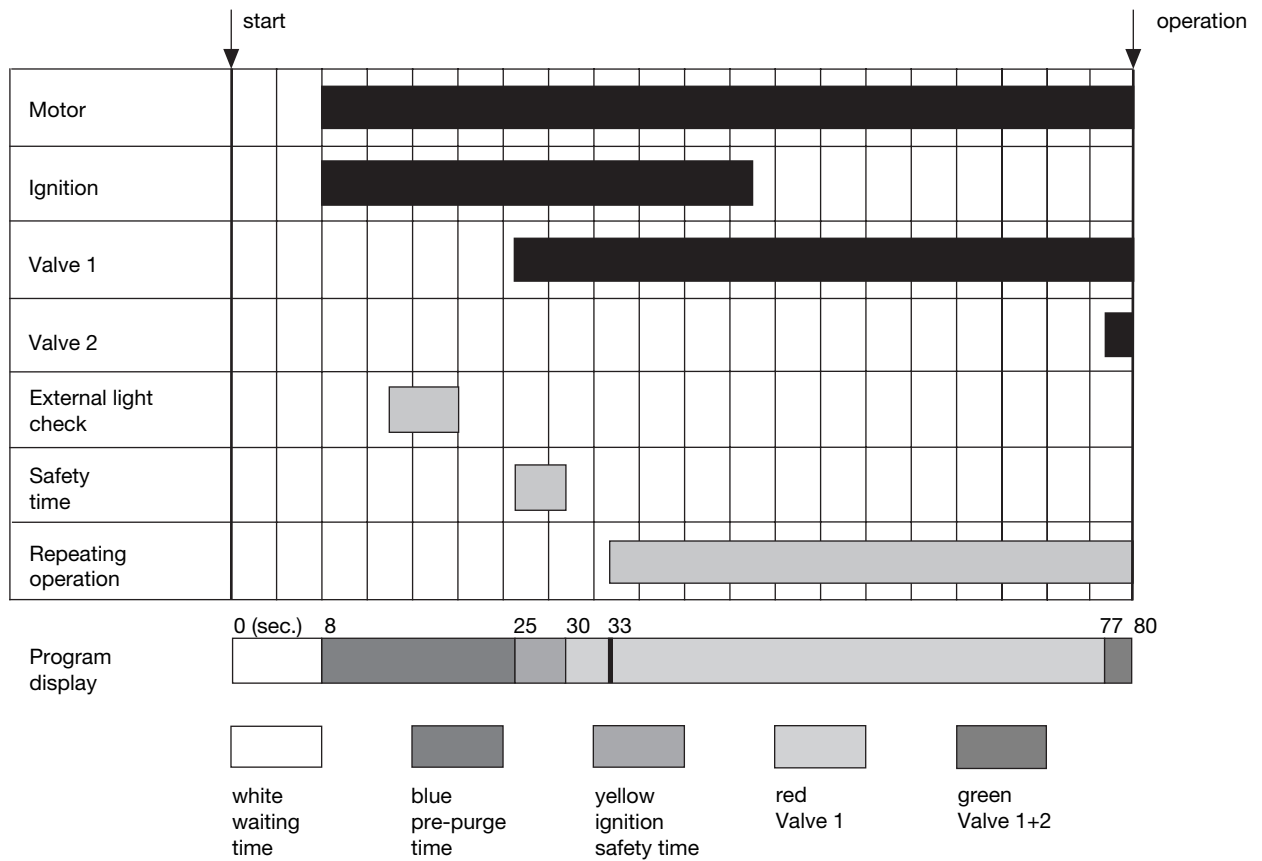

**MMD WITH WIRING BASE**

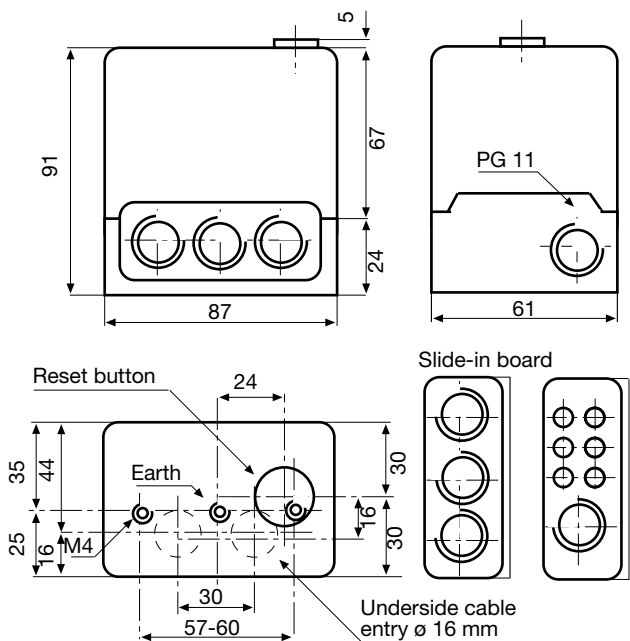

**IRD 1010**

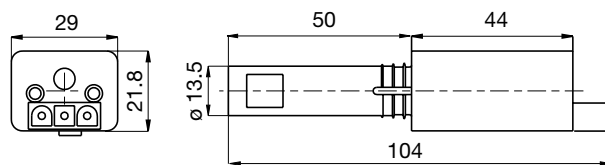

**SUPPORT FOR IRD 1010**

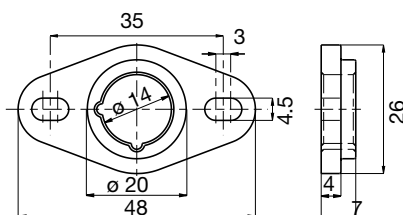

**VARIATION**

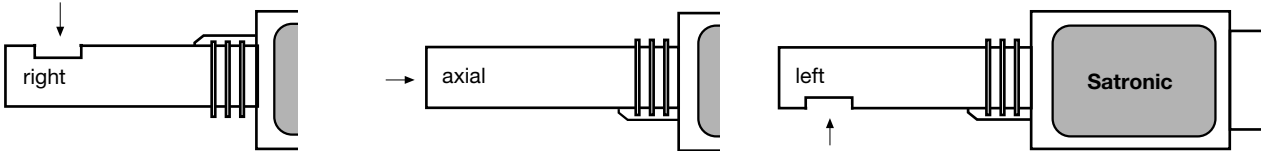

**ORDERING INFORMATION**

ITEM	DESIGNATION	ITEM NO.
Control box	MMD 900.1	06514
Socket	Socket 701 ABEN	70001
or	Socket MW 880 ABC	74001
Slide-in board	PG-plate	70502
optional	Cable terminal plate	70501
Flame detector	IRD 1010 right	16501
optional	IRD 1010 axial	16502
optional	IRD 1010 left	16503
Support for flame sensor	Support M 74	59074
Connectioncable	Plug type, 3 core cable, 0.6 m with tag wire ends	7236001

The above ordering information refers to the standard version.  
Special versions are also included in our product range.

Specifications subject to change without notice.

**MMD 900.1**



A Honeywell Company

Satronic AG  
Brüelstrasse 7  
Postfach 324  
CH-8157 Dielsdorf

## Oil Burner Control Box

**For forced-draught burners with a capacity of over 30 kg/hour in intermittent operation, 1 or 2-stage**

**Flame detector:**

- photo-resistor FZ 711 S
- infrared flicker detector IRD 1010

### INTRODUCTION

The TMO 720-4 oil burner control box is capable of controlling and monitoring medium to high capacity forced-draught burners (tested and approved as per EN 230).

It can be employed, as preferred, for multi-stage or modulating operation, with burners of any nominal rating or with stationary warm air generators (as per DIN 4794).

The TMO 720-4 is fully interchangeable with the earlier version, the TMO 720-2.

### CONSTRUCTIONAL FEATURES

The control box is enclosed in a protective, flame resistant, transparent, plug-in type plastic housing, and includes:

- Synchronous motor with reduction gearing driving cam switches
- Cam switches with informative, coloured programme indicator
- 16-way cam switch assembly controlling the programme sequence
- 2 DC relays and 1 remanence relay on a common yoke
- Plug-in printed circuit board with electronic components

On the underside of the unit are robust plug terminals where monitoring of the air damper and mode of operation ("repeat cycle" or "direct lockout") can be programmed via three wire jumpers, which may be cut as required.

The following important indicators and operating controls can be found on the front of the control box:

- Reset button incorporating a signal lamp for lockout
- Coloured programme indicator
- Central screw fastening



### TECHNICAL DATA

Supply voltage	220 / 240 V (-15... +10%) 50 Hz (40 - 60 Hz)
AC frequency variations	result in proportional timing deviations
Fuse rating	max. 10 A rapid, 6 A slow
Power consumption	15 VA
Max. current per output terminal	4 A
Total	6 A
Approved for	burners of unlimited capacity as per EN 230
Pre-purge time with air damper open	30 sec.
Air damper open/close time	<60 sec.
Pre-ignition time	30 sec. or 2 sec. (terminal 10)
Safety interval (fixed)	5 sec.
Post-ignition time (fixed)	7,5 sec.
2nd stage delay	11,5 sec.
Reset delay	none
Permissible ambient temp.	-20° C... +60° C for control box and photo-resistor
FZ 711 S light sensitivity	
Red lettering	better than 10 lux, radial
White lettering	better than 10 lux, axial and radial
Photo-resistor cable length	Standard 0.6 m, max. 10 m, max. 200 m laid separately
Insulation standard	IP 44
Weight	approx. 950 g with baseplate and photo-resistor

## TECHNICAL FEATURES

1. The control box and photo-resistor can be operated at an ambient temperature of up to 60° C.
2. The timing sequence is controlled by a synchronous motor driving a cam switch assembly. Timing is therefore practically unaffected by variations in the mains voltage.
3. A coloured programme indicator allows visual monitoring of the programme sequence.
4. A remote reset switch can be connected in addition to the built-in reset switch on the control box. Provision has also been made for a remote lockout indicator.
5. A keyed fit ensures that the wrong type of control box cannot be fitted to the baseplate.
6. DC operation of both relays is reliable and clear-cut, at the same time providing a check of the mains voltage.
7. Wiring of the baseplate is eased by the provision of 4 neutral and 3 earth terminals.
8. By cutting the appropriate wire jumper on the underside of the unit, "direct lockout" or "repeat cycle" operating modes can be programmed. The air damper monitoring mode is selected in the same way.
9. If no return signal is received indicating that the air damper has reached the end of its travel, the control box switches to lockout, causing the burner system to shut down.
10. No separate air damper contact is required for release of the high-flame valve.
11. Short or long pre-ignition time can be selected.
12. All electrical and electronic components are incorporated on two plug-in type printed circuit boards.

## INSTALLATION INSTRUCTIONS

1. The control box can be mounted on the burner, or installed as part of a separate switching system. It is suitable for mounting in any attitude.
2. The wiring must be checked exactly, ensuring that the control box has been correctly installed. Incorrect wiring puts the safety of the burner system at risk, and could cause damage to the control box or system.
3. It is important that no stray light is allowed to reach the photo-resistor. Stray light can enter the burner through the inspection window or through cracks, or be caused by the glowing refractory layer on the inside of the combustion chamber.  
Stray light can cause the control box to switch to lockout.
4. The control box and photo-resistor should be mounted in a position where the ambient temperature cannot, on any account, rise above 60° C. At higher temperatures there is a risk of unreliable operation, and the life of the control box will be reduced.
5. The unit is designed to withstand moderate vibration, as experienced in burner systems. It should, however, be mounted in a position where it is not exposed to harsh vibration and is protected from bumps.
6. If during the test of the burner the click-rate (according to EN 55014) is higher than the max. allowed valve, a X2-capacitor of 0.1 µF can be connected between terminal 8 and 9.

## PROGRAMME SEQUENCE

### Normal start procedure

When the controlling thermostat calls for heat, the burner motor and ignition circuits are switched on. If no air damper lock is fitted, the sequence switches immediately to pre-purge. Otherwise, the sequence only continues when the signal indicating opening of the air damper has been received.

After 30 sec. pre-purge time, the signal commanding the air damper to remain open is interrupted and the switching sequence stops until the "air damper min." signal is received.

The programme sequence is not interrupted if no air damper monitoring is employed. The switching sequence continues and the low-flame valve is opened.

When the flame has been established, and is "seen" by the photo-resistor, the built-in flame-monitoring relay allows the programme sequence to continue to post-ignition and high flame.

The release for high-flame operation causes a voltage to be applied to the high-flame thermostat via terminal 6. If the thermostat demands high flame, the air damper is first opened via terminal 12. On receipt of the signal for "air damper max.", high-flame valve V2 is also opened.

Programme sequence switching finally stops and the control box is in its normal operating mode.

### Start sequence without establishment of flame

Less than 5 sec. after release of fuel, the control box switches to lockout.

The indicator on the reset button lights up. The burner system only goes back into operation after the built-in reset button has been pressed or the remote reset has been activated. The normal start sequence begins again after reset, at the end of the safety interval.

### Loss of flame during operation

Loss of flame during operation is instantly detected by the photo-resistor due to the absence of radiated light. Depending on how the control box has been "programmed", this is followed by:

- a) If jumper II has been cut for "repeat cycle" operation:  
Immediate interruption of the supply of fuel and repeat of normal start sequence.
- b) If jumper II is intact, for "direct lockout" operation:  
The control box immediately switches to lockout. A new start sequence can only begin after the reset button has been pressed.

When the ignition transformer is connected to terminal 10, the control box employs a short pre-ignition period. In this way, the ignition procedure is only initiated at the end of pre-purge.

## PROGRAMME SELECTION

### "Repeat cycle" or "direct lockout"

Jumper II on the underside of the unit should be cut if the control box is required to repeat the start sequence after loss of flame during operation.

By connecting terminals 17 and 18 on the baseplate, the control box can again be programmed for "direct lockout" operation.

### Monitoring of the air damper

No monitoring:

Jumper I on the underside of the unit should be left intact. Terminals 14 and 15 on the baseplate should be connected together.

Monitoring of "air damper max.":

Jumper I on the underside of the unit should be left intact. Switch indicating end of air damper travel should be connected between terminals 14 and 15.

Monitoring of "air damper min.":

Cut jumper I on the underside of the unit. Connect terminals 14 and 16 together and the air damper end switch between terminals 14 and 15.

Monitoring of air damper "max." and "min.":

The circuit should be as shown in fig. 1, with wire jumper I on the baseplate cut.

No lockout caused by absence of signal indicating air damper at end of travel:

Jumper III should be cut

- e.g.:
- If air damper open/close time is greater than 60 sec.
  - In conjunction with pre-heating for heavy oil

**CIRCUIT DIAGRAM - WITH AIR DAMPER CONTROL**

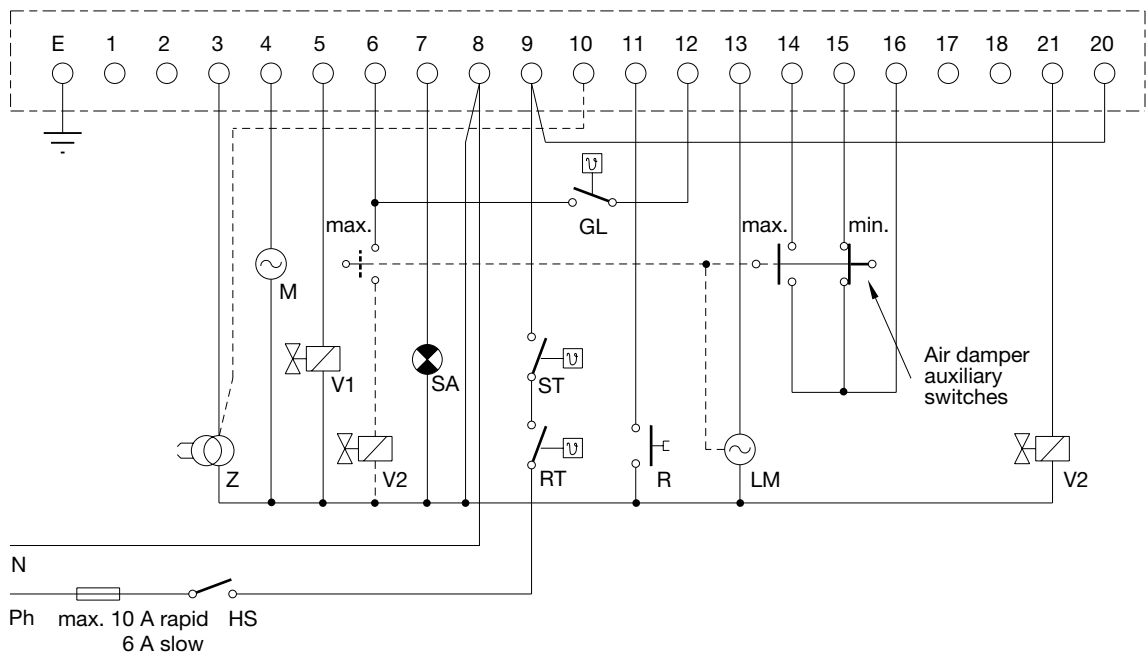

**FZ WIRING DIAGRAM**

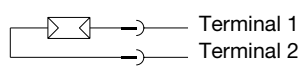

**IRD CONNECTION**

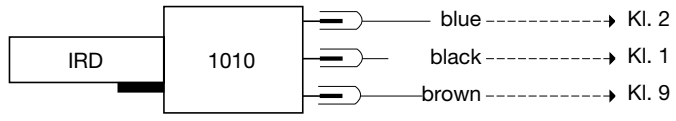

- HS Main switch
- ST Safety thermostat
- RT Controlling thermostat
- GL High-flame thermostat
- SA Remote lockout indicator
- LM Air damper motor
- M Burner Motor
- Z Ignition
- R Remote reset
- V1 Solenoid valve, low flame
- V2 Solenoid valve, high flame
- FZ Photo-resistor

**REFERENCE WIRING V2**

- On actuating-drives with 1 "max."-contact:  
V2 on terminal 21.
- On actuating-drives with 2 "max."-contacts:  
V2 by 2nd "max."-contact on terminal 6.

**CIRCUIT DIAGRAM - WITHOUT AIR DAMPER CONTROL**

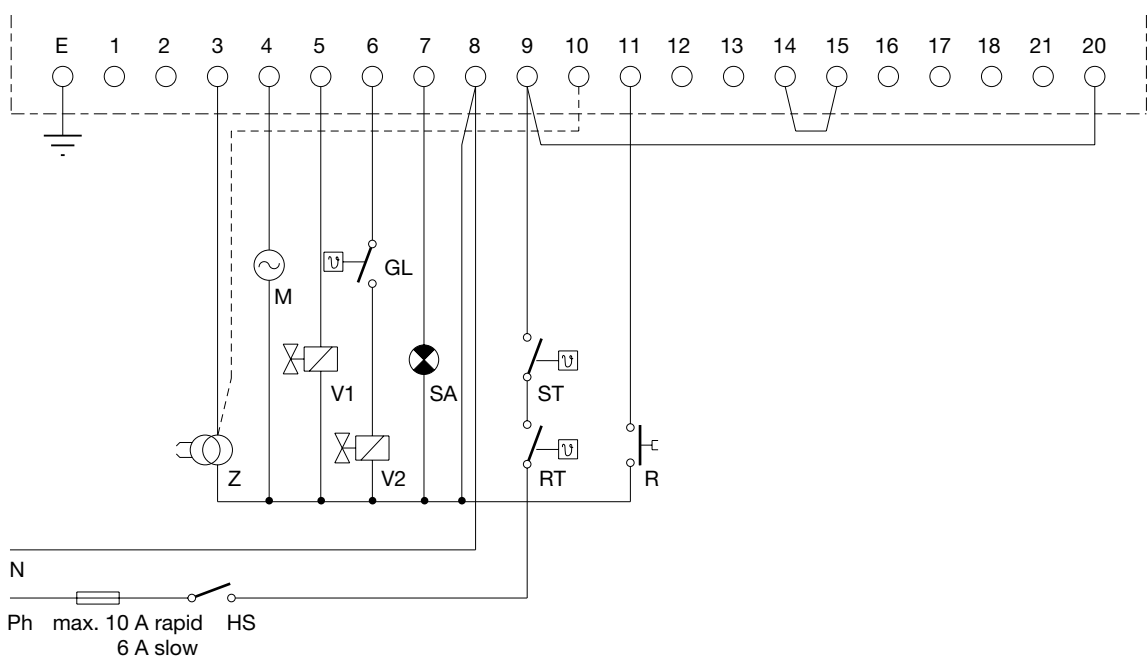

# GENERAL CIRCUIT DIAGRAM

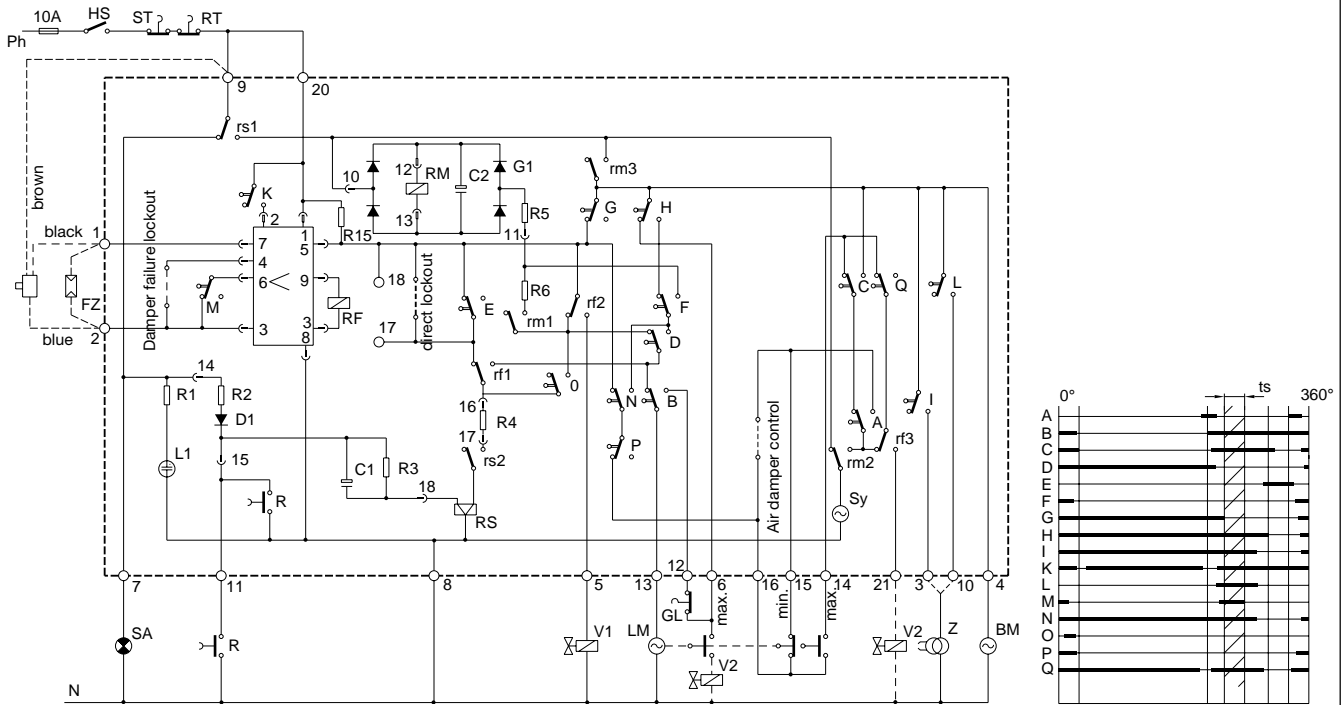

- |    |                           |   |                           |     |                                 |
|----|---------------------------|---|---------------------------|-----|---------------------------------|
| RM | Motor relay               | E | Repeat cycle              |     | Relay contacts                  |
| RF | Flame relay               | F | RM on and hold            | rs1 | Lockout shutdown                |
| RS | Lockout relay             | G | V1 open, beginning of ts  | rs2 | Lockout relay self interrupt    |
| R  | Reset                     | H | Release for high flame    | rm1 | RM hold                         |
|    | Cam switches              | I | Long pre-ignition         | rm2 | Synchronous motor control       |
| A  | Synchronous motor control | K | LM operation supervision  | rm3 | Main contact                    |
|    | Air damper monitoring     | L | Short pre-ignition        | rf1 | Lockout initiation              |
| B  | Air damper control        | M | Programme start           | rf2 | Hold V1                         |
| C  | Synchronous motor control | P | Check rf1                 | rf3 | Hold V2                         |
|    | Air damper monitoring     | Q | Synchronous motor control | tv  | Pre-purge time with damper open |
| D  | Switchover to RM hold     |   | Air damper monitoring     | ts  | Safety time                     |

# PROGRAMME SEQUENCE

**a) Start sequence, flame established**

**b) Start sequence, flame not established**

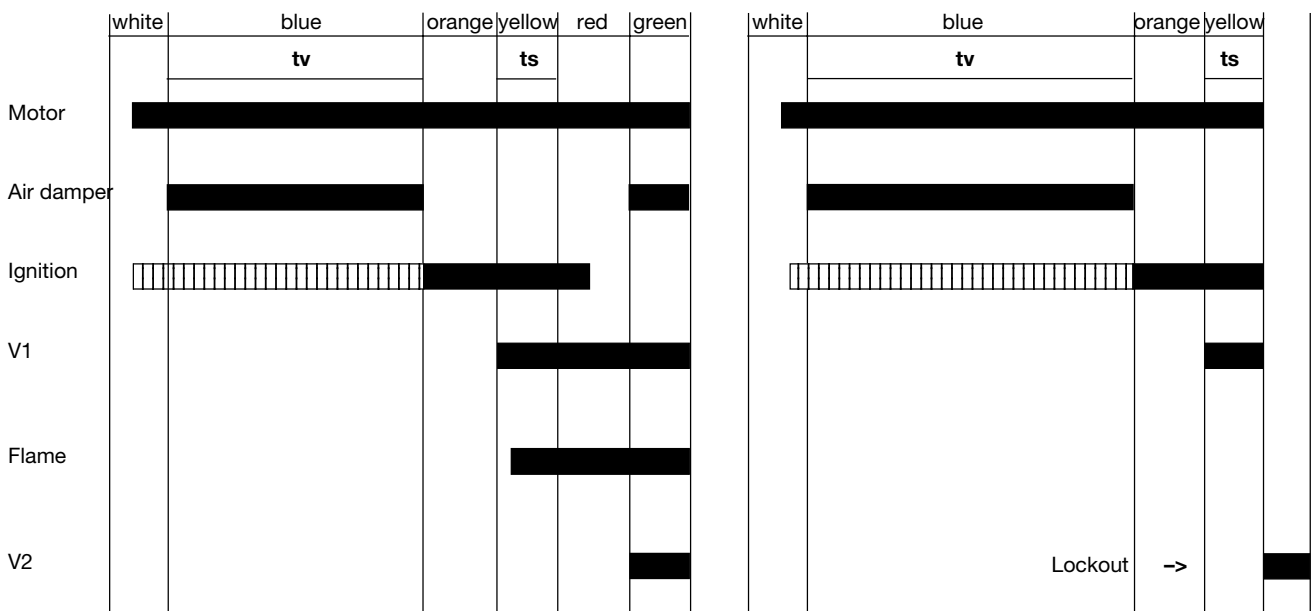

## SUMMARY OF ALL SAFETY FEATURES

1. Loss of flame during operation results in immediate cancellation of fuel release, followed by direct lockout or repeat of start sequence, as desired.
2. Start without flame establishment causes cancellation of fuel release within 5 sec. of its initial release.
3. Fuel is supplied only when all parts of the unit are functioning correctly. All safety circuits are automatically checked before fuel is released.
4. Continuous air damper monitoring is possible, with air damper failure resulting in lockout. This precaution also protects the ignition transformer from overload.
5. Failure of the mains supply always results in a normal start sequence on restoration of power. If the control box is at lockout, failure of the mains supply does not cause it to reset.
6. Stray light during the pre-purge phase leads to shutdown and lockout.
7. Increased sensitivity of the flame detector during the pre-purge phase ensures that stray light is detected, or deterioration of the photo-resistor's capabilities is noticed before it becomes a risk to the safety of the system. The circuit responsible for stray light security is of a fail-safe design.

## COMMISSIONING AND MAINTENANCE

The control box requires no maintenance. It should therefore not be opened.

The photo-resistor should be checked periodically at the light-sensitive side for cleanliness. Dirt and dust reduce the amount of light it receives, which could lead to a shutdown. Due to the very low variations in the voltage produced by the photo-resistor, measurement of this voltage does not provide reliable results. As a test, a resistor (R=4 k 7) should be connected in series with the FZ 711 S. If the control box does not go to lockout when the next start sequence begins, the amount of light being "seen" by the photo-resistor is satisfactory.

The resistor must be removed when the test has been completed.

On commissioning the system, and when carrying out servicing work, correct operation of the monitoring systems should be checked as follows:

1. Attempt to start the burner with the photo-resistor pulled out and covered up. Lockout should take place at the end of the safety interval (yellow sector). The photo-resistor must be well covered up, otherwise lockout will occur due to stray light.
2. Attempt to start with the photo-resistor exposed to stray light (the lighting in a reasonably bright room is sufficient). A stray-light shutdown should result.
3. Start the system, with the photo-resistor in position, allowing the flame to become established and the programme sequence to complete (end of green sector). Pull out the photo-resistor and cover it up. The result should be as follows:
  - a) Lockout, if the control box is programmed for "direct lockout" operation
  - b) If programmed for "repeat cycle" operation, fuel should be cut off immediately, and the sequence restarted.

## ADDITIONAL SAFEGUARD AGAINST STRAY LIGHT AND PHOTO-RESISTOR FAILURE

During the pre-purge phase, the control box increases the sensitivity of the flame signal amplifier to a level considerably higher than that for normal burner operation.

The slightest stray light, or even a minor deterioration of the photo-resistor's operating characteristics, cause a stray-light shutdown before fuel is released.

## FAULT FINDING

1. Burner does not start, programme indicator stops at end of green section, no lockout indicated:
  - a) Incorrect wiring
  - b) No voltage at terminal 9
  - c) No neutral connection
2. Lockout, with programme indicator at beginning or end of blue section:
  - a) No signal indicating "damper max."
  - b) No signal indicating "damper min."
  - c) In systems which do not provide monitoring of the air damper position, jumper I on the underside of the unit has been cut, or the connection in the baseplate between terminals 14 and 15 is missing.

**Caution:** The signals indicating the air damper positions "max." or "min." for pre-purge or end of ignition, must be received within 60 sec. At the end of this delay, lockout will occur, preventing the burner from remaining permanently on pre-purge.

3. Lockout in blue section:
  - a) Stray light detected by photo-resistor
  - b) Photo-resistor defective
  - c) Solenoid valve leaking or open
  - d) Defect in control box flame-monitoring circuit
4. Burner starts and fuel release signal is given, but no flame is established. Lockout at the end of the yellow section:
  - a) No ignition
  - b) Fuel supply fault
  - c) Solenoid valve defective or not connected
5. Burner starts and flame is established, lockout occurs at the end of the yellow section:
  - a) Photo-resistor is dirty
  - b) Photo resistor installed incorrectly-"sees" no light
  - c) Photo-resistor defective or connected incorrectly
  - d) Control box flame-monitoring circuit defective
  - e) No voltage at terminal 20

**Caution:** When a control box switches to lockout, it is, in most cases, performing the function for which it was designed. Apart from the possibilities already mentioned, lockout can be caused by one or more of the following:

- 1) Ignition spark in wrong position
- 2) Fuel tank empty
- 3) Fuel valve closed
- 4) Oil filter blocked
- 5) Defective oil pump
- 6) Poor combustion
- 7) Unreliable burner start

**TMO 720-4 WITH BASEPLATE**

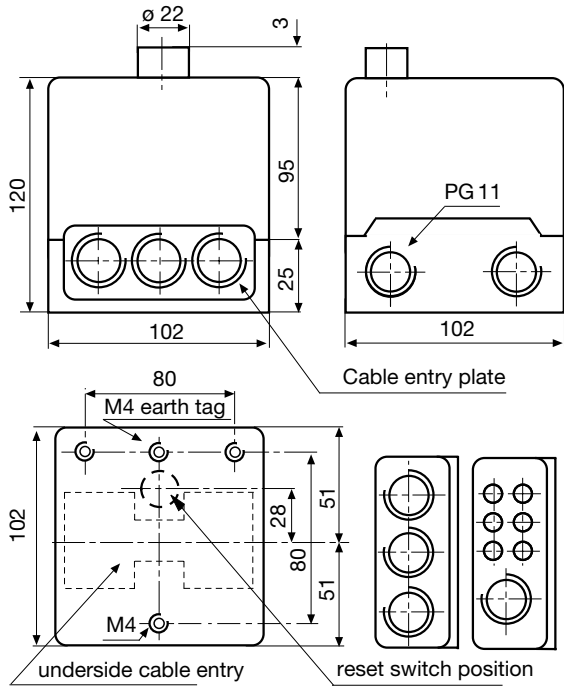

**FZ 711 S PHOTO-RESISTOR**

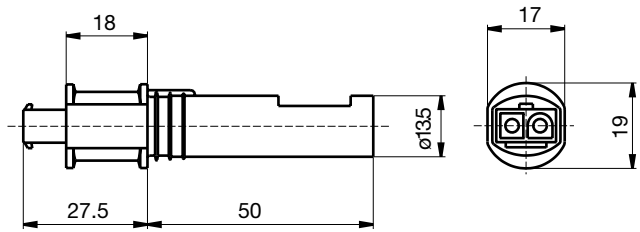

**HOLDER ZU FZ 711 AND IRD 1010**

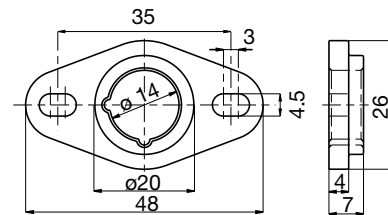

**IRD 1010**

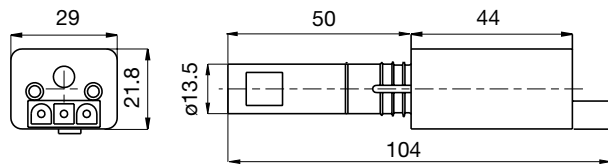

**IRD VARIATIONS**

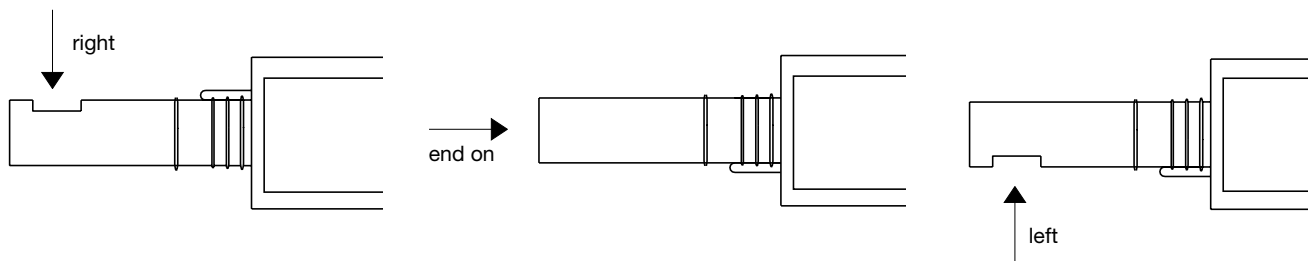

**ORDERING INFORMATION**

ITEM	DESIGNATION	ITEM NO.
Control box	TMO 720-4	08001
Baseplate	TMO base	70201
Insert plate (2x)	PG plate	70502
optionally	Cable entry plate	70501
Flame detector	FZ 711 S red	40001
optionally	FZ 711 S white	41001
Infrared flicker detector	IRD 1010 right	16501
optionally	IRD 1010 end on	16502
optionally	IRD 1010 left	16503
Flame detector mount	FZ Holder M74	59074
FZ 711 S cable	Sensorcable, 2-wire, 0.5 m with tag wire ends	7225001
IRD / FZ cable	Sensorcable, 3-wire, 0.6 m, with tag wire ends	7236001

The above ordering information refers to the standard version.  
Special versions are also included in our product range.

Specifications subject to change without notice.

**TMO 720-4**



Satronic AG  
Brüelstrasse 7  
Postfach 324  
CH-8157 Dielsdorf

## Oil Burner Safety Control

**For oil burners on Direct Air Heaters and for burners above 30 kg/h throughput for intermittend operation, with or without oil preheater, 1- or 2-stage, recycling and post-purge after loss of flame**

**Flame detection:**

- Photoresistor MZ 770 S
- Infrared-flicker detector IRD 1010
- UV flame sensor UVD 970

### INTRODUCTION

The DKW 972/976 oil burner safety control boxes are suitable for oil burners with or without preheater with throughputs exceeding 30 kg/h. They are approved and certified according to the applicable European standards and regulations.

The microprocessor- based programming sequence ensures extremely stable timings independent of voltage variations, ambient temperature and/or switch-on cycles. The built-in information system not only provides a continuous monitoring of the actual state of the box (very helpful especially for monitoring the start-up phase) but also informs about the cause of a possible lock out. The lock out cause is stored in such a way that it can be retrieved even after a power failure. The control box is designed for maximum safety in case of fluctuations in the voltage supply. If the mains voltage drops below the permitted level, operation is interrupted and the control box automatically prevents the start sequence from being repeated. In this way, the safety of the system is not put at risk by a drop in the mains voltage. This low-voltage protection works not only during start-up but also permanently during operation.

### TYPES AVAILABLE

- DKW 972 2-stage operation,  
without terminals for oil preheater
- DKW 976 2-stage operation,  
with override contact,  
with terminals for oil preheater

### CONSTRUCTIONAL FEATURES

The control box circuitry is protected by a flame resistant, transparent plug-in type plastic housing. A central fixing screw locks the control box to the wiring base. The plug-in control box incorporates the microprocessor based timer, flame check and reset circuits. Manual reset from lock out and set to lock out is provided by a push button with an integrated lock out signal lamp. The wiring base S98 is equipped with spare- and extraterminals and allows together with a variety of cable entry points utmost flexibility of electrical wiring.



The DKW 972 is with the exception of the IRD connection compatible to the TTO 872 and MMO 872. The DKW 976 is with the exception of the IRD connection compatible to the TTO 876 and MMO 876.

### Timings (sec.)

Model	waiting time start	max. warm-up time oil preheater <b>ta</b>	Pre-purge and pre-ignition time <b>tv1</b>	Stray light monitoring <b>tf</b>	safety time <b>ts</b>	Post-ignition time after V1 <b>tn</b>	delay time to V2 <b>tv2</b>
<b>05</b>	0	400	20	5	5	7	20



### TECHNICAL DATA

Operating voltage	220 / 240 V (-15... +10%) 50 Hz (±5%)
Fuse rating	10 A fast, 6 A slow
Power consumption	ca. 15 VA
Max. load per output	
- term. 3 ignition trafo	1.5 A, cos φ 0.2
- term. 4 motor	2.0 A, cos φ 0.4
- term. 5 solen. valves	1.0 A, cos φ 0.4
- term. 6 solen. valves (DKW 972)	1.0 A, cos φ 1.0
- term. 6 oil preheater (DKW 976)	2.0 A, cos φ 1.0
- term. 7 alarm indicator	1.0 A, cos φ 0.4
- term. B solen. valves (DKW 976)	1.0 A, cos φ 0.4
total load	5.0 A, cos φ 0.4 max. 10 A during 0,5 sec
Reset time from lock out	none
Pre-purge after loss of flame during operation	60 sec
Flame detectors	< 2 m length of cable side-on and end-on viewing better 6 Lux side-on or end-on viewing end-on viewing
MZ 770 S	
Light sensitivity	
IRD 1010	
UVD 970	
Weight incl. Wiring base	190 g
Mounting position	any
Protection class	IP 40
Approved ambient parameter for control and flame detector	max. 95% at 30° C
- for operation	-20° C... +60° C
- for storage	-20° C... +80° C
Build-up of ice, penetration of water and condensing water are	inadmissible
Approvals according to European standards	EN 230, as well as all other relevant Directives and standards

## APPLICATION FEATURES

### 1. Information system

The information system is microprocessor based and reports on all aspects of burner control box operation and flame supervision. It informs continuously about the actual programming sequence the unit is just performing. Besides monitoring of the programming sequence it also allows to identify errors during start-up of operation without any additional testing devices. The automatically performed diagnoses is a valuable tool which facilitates service/maintenance work and therefore saves costs. The analyses of the error cause can be done directly on stage or if not possible afterwards as the lock out reason is stored in a non-volatile lock out mode memory.

The information system communicates with the outside world using a LED (the used Flash-Code is similar to the Morse-Code). The messages are optically transmitted by flashing appropriately a LED. Using an (optional) additional terminal the messages can be recorded and displayed in easy readable form.

#### 1.1 Programming sequence display

The built-in microprocessor controls not only the programming sequence but the information system too. The individual phases of the programming sequence are displayed as Flash-Code.

The following messages can be distinguished:

Message	Flash-Code
waiting for release thermostat (DKW 976 only)	.
pre-ignition tv1	.
safety time ts and post ignition tn	■   .
delay 2nd stage tv2	■     .
running	_
low mains voltage	■ ■ _
post-purge	.

#### Description

| = short pulse

■ = long pulse

. = short pause

\_ = long pause

### 1.2 Lock-out diagnoses

In case of a failure the LED is permanently illuminated. Every 10 seconds the illumination is interrupted by a flash code, which indicates the cause of the error. Therefore the following sequence is performed which is repeated as long as the unit is not reset.

Sequence:

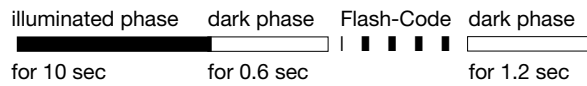

#### Error diagnosis

Error message	Flash-Code	Possible fault
lock out	■ ■ ■ ■	within lock out safety time no flame establishment
stray light	■ ■ ■	stray light during monitored phase, detector may be faulty
limit thermostat time-out (only DKW 976)	■ ■	contact of thermostat release does not close within 400 sec.

#### Flash-Code for manual lock out

manual/external    | | ■ ■ ■ \_ ■ ■ ■ ■

lock out

(see also 4. lock out and reset)

### 2. Flame control

The following detectors can be used for flame supervision:

- for yellow oil flame: photoresistor MZ 770 S
- for blue or yellow flame: infrared-flicker detector type IRD 1010 or as an alternative the UV solid state flame sensor UVD 970

Generally, the no flame signal is generated at light levels below 3 Lux with respect to the operating cycle of the control. According to EN 230 stray light safety level has to be established in conjunction with the accompanying burner. Connecting the IRD 1010 or UVD 970, the correct wiring has to be observed.

#### 2.1 Stray light monitoring

The stray light check is performed at the end of the pre-purge time for the duration as mentioned in the technical datas.

### 3. Burner control

#### DKW 976 with oil preheater

The fuel heater of the burner has to have a temperature control switch. The closing contact-switch of the heater has to be connected between terminals 4 and 6. A special contact in the control unit connects the thermo-switch of the heater as soon as the burner is operating and a photocurrent is generated. Therefore an interruption of the burner operation due to a decrease in oil temperature is prevented (e.g. in case of high oil flow).

According to EN 230 A 2.1, the short circuiting of the thermostat is allowed only for an oil flow of max. 10 kg/h oil. Burners with a higher throughput have to shut down if the oil temperature gets below the allowed minimum. In such a case the thermo-switch has to be put in the phase-circuit and terminals 4 and 6 have to be connected with a link.

The contact of the release thermostat of the oil preheater is monitored. If the contact does not close within the pre-defined time (400 sec), the programmer goes into lock out mode.

Therefore excessive oil temperatures in the preheater over long periods can be prevented avoiding cracking of the oil and subsequent blocking of the preheater or nozzle.

#### DKW 976 without oil preheater

In such a case the terminals 4 and 6 have to be connected with a link.



#### Attention

The switch of the release thermostat for the oil preheater must never be linked between 4 and 9 or 6 and 9!

During lockout, the preheater will not be separated from power. This could lead to a defective pre-heater due to burn out its heating winding.

### 4. Lock out and reset

The unit can be reset or brought into lock out mode in two different ways:

#### Internal

In the lock out case the unit can be reset by pushing the built-in button meaning a new start-up cycle is performed.

#### External

Instead of using the built-in lock out button the same function can be achieved by using an external button which connects terminal 9 with A (see also circuit and block diagram).

If the pushbutton (internal or external) is pressed during normal operation or during the start sequence for more than 3 sec. and afterwards released, the control box will perform a shutdown.



#### Please note

The unit can only be brought to lockout mode or be reset if power is applied to the unit.

### 5. Low-voltage protection

The mains voltage has to be more than  $187 V_{eff}$  in order to allow the unit to perform a start-up.

The mains voltage is not only monitored in the start-up phase but also permanently during operation. If the voltage drops below  $< 160 V_{eff}$  during start-up or run time the control box goes into lock out mode. If the voltage rises again, the control box performs automatically a start-up as soon as the mains voltage is  $> 187 V_{eff}$ .

### 6. Safety

The design and control sequence of the DKW 972/976 controls will comply with the currently applicable standards and regulations (see also TECHNICAL DATA).

The controller is recycling. This means in case of loss of flame during operation the shut-off valves close immediately and a post-purge of 60 seconds is follows. Afterwards a new start up will be performed.

### 7. Mounting and electrical wiring

Wiring base:

- 3 earth terminals with additional terminal for burner earthing
- 3 neutral terminals with internal permanent connection to neutral terminal 8
- 2 independant spare terminals (S1 and S2)
- extra terminals A, B and C are standard
- 2 slide-in plates and 2 easy knock out holes (PG11 thread) plus 2 knock out holes in the base bottom facilitate the base wiring

The digital controls are ideally wired on the new wiring bases S98, which are equipped with (terminals B and C are only for some special types of DMO or DMG) terminal A, which is used for the remote reset / remote lockout functions.



#### Please note

To assist trouble-free operation the main neutral connection terminal in the wiring base must be fully tightened. The terminal screws are already in the undone position. To connect a wire to the terminal, the screw only needs to be fastened.

General: The control box and detector probes should not be subjected to excessive vibration.

## INSTALLATION INSTRUCTIONS AND MAINTENANCE

### 1. Important notes

- The controls must be installed by qualified personnel only. The relevant national regulations have to be observed.
- On commissioning the wiring has to be carefully checked according to the appropriate diagram, incorrect wiring can damage the unit and endanger the installation.
- The fuse rating has to ensure that the limits specified in TECHNICAL DATA will not be exceeded. If these precautions are not observed, the effect of a short circuit can cause severe damage to the control and installation.
- For safety reasons a minimum of one control shutdown per 24 hours has to be observed.
- Disconnect the mains before the control box is plugged in or out.
- The control box is a safety device and must not be opened!

### 2. Function control

For safety reasons the flame detection system should be tested on commissioning the installation as well as after a service or longer shut-down.

- Start-up with covered flame detector
  - After safety time is over the unit has to go into lock out mode!
- Start-up with exposed flame detector
  - After 17 sec prepurge time the unit has to go into lock out mode!
- Normal start up with burner in the normal/operation position, cover up the flame detector.
  - The shut-off valve must close immediately and a post-purge of 60 seconds must follow.
  - Afterwards a normal start up should follow and at the end of safety time the unit has to go into lock out mode!

### 3. Fault finding

The built-in information system facilitates the trouble shooting in the case of problems occurring during start-up or during operation.

A list of possible lock out messages can be found in APPLICATION FEATURES chapter 1.2.

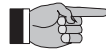

#### Please note:

**The control box is locked in lock out mode and the reason for the lock out is displayed until the control box is reset, either by an internal or external reset (see also subject "3. Lock out and reset").**

Removing the control box from its wiring base or by interrupting the supply line may not reset a lock out (according to EN 230). Therefore, by applying power, the fan motor/nozzle preheater switches on for 2-3 secs. before the control box goes to lock out again and the cause of the last lock out.

Error	Possible fault
Burner not working	<ul style="list-style-type: none"><li>- Thermostat circuit open</li><li>- Faulty electrical wiring</li><li>- Oil preheater defective</li><li>- mains voltage &lt; 187 V</li></ul>
Fan motor/nozzle preheater starts for a short period of time, control box goes to lock out	<ul style="list-style-type: none"><li>- Control box has not been reset</li></ul>
Burner starts, flame not established, lock out	<ul style="list-style-type: none"><li>- Stray light on flame detector</li><li>- No ignition or no fuel</li></ul>
Burner starts, flame established, after safety time, lock out	<ul style="list-style-type: none"><li>- Dirty or faulty flame detector</li><li>- Insufficient light on detector</li><li>- Sensitivity adjustment too low on IRD</li></ul>

**CIRCUIT AND TIMING DIAGRAM DKW 972**

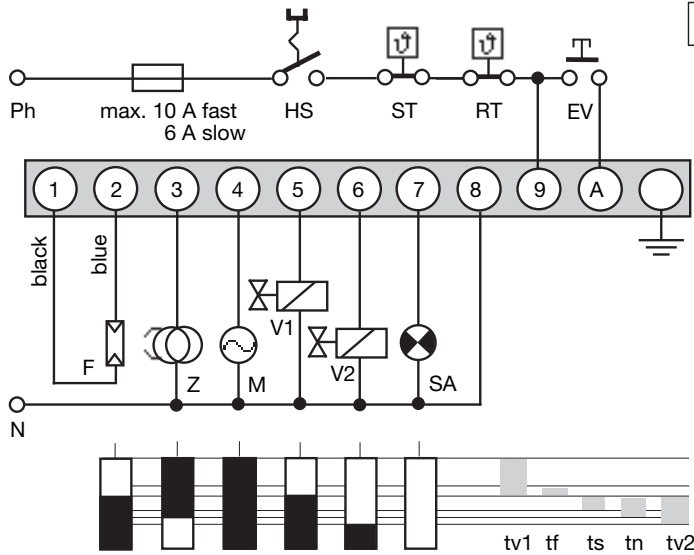

**IRD-/UVD-CONNECTION**

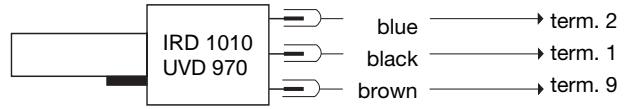

- HS Mains switch
- ST Limit thermostat
- RT Control thermostat
- EV External reset and lock out button
- F Flame detector MZ 770 S (IRD 1010,UVD 970 see separate diagram)
- Z Ignition
- M Burner motor
- V1 Oil solenoid valve, 1st-stage
- V2 Oil solenoid valve, 2nd-stage
- SA External lock out signal
- tv1 Pre-purge and pre-ignition time
- tf stray light monitoring
- ts Lock out safety time
- tn Post-ignition time
- tv2 Delay time to oil V2

**CIRCUIT AND TIMING DIAGRAM DKW 976**

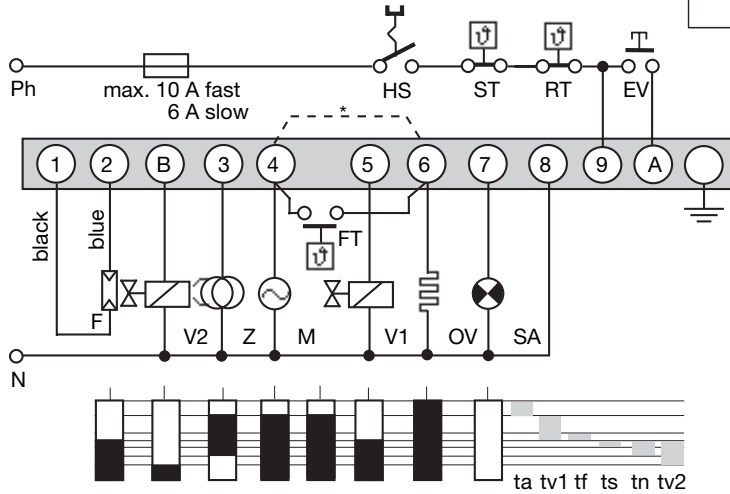

**IRD-/UVD-CONNECTION**

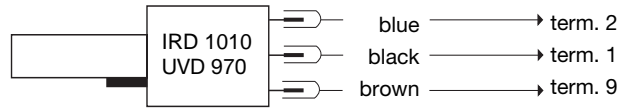

- HS Mains switch
- ST Limit thermostat
- RT Control thermostat
- EV External reset and lock out button
- F Flame detector MZ 770 S (IRD 1010,UVD 970 see separate diagram)
- Z Ignition
- M Burner motor
- V1, V2 Solenoid valves
- OV Oil preheater
- FT Release thermostat oil preheater
- \* For burners without fuel heaters term. 4 and 6 have to be connected with a link
- SA External lock out signal
- ta Pre-heat-time oil preheater
- tv1 Pre-purge and pre-ignition time
- tf stray light monitoring
- ts Lock out safety time
- tn Post-ignition time
- tv2 Delay time to oil V2

**BLOCK DIAGRAM DKW 972**

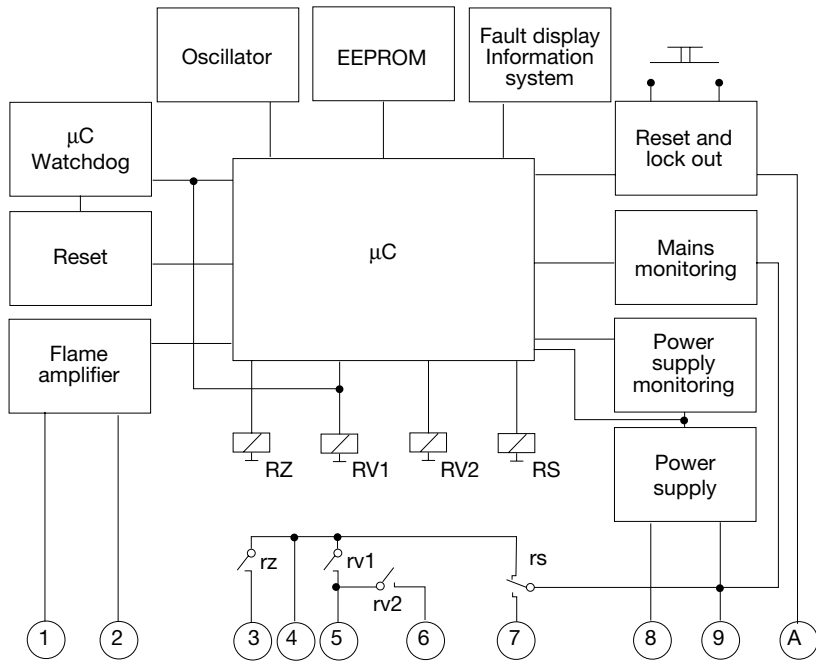

**BLOCK DIAGRAM DKW 976**

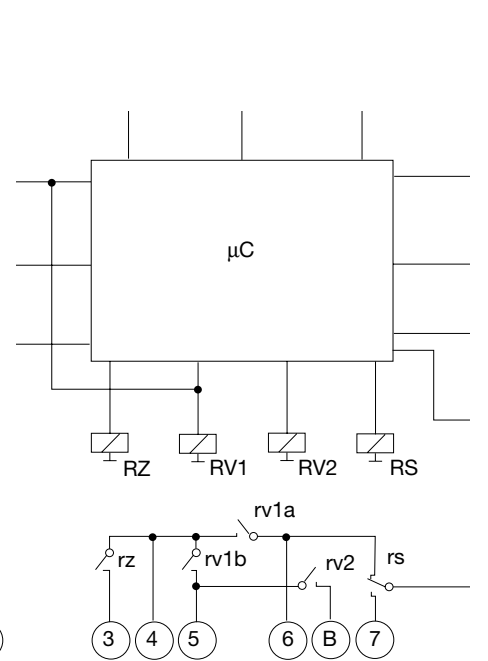

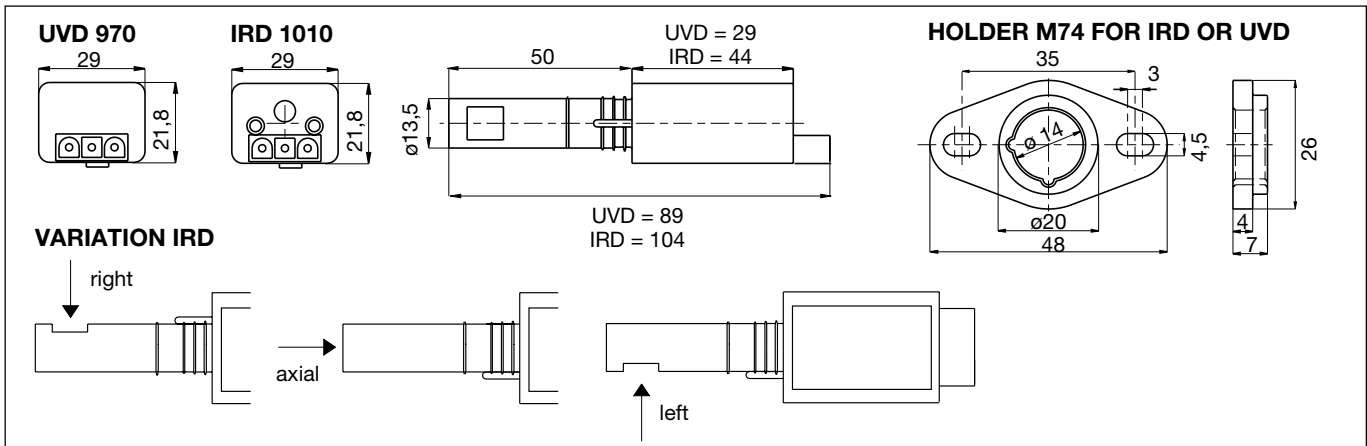
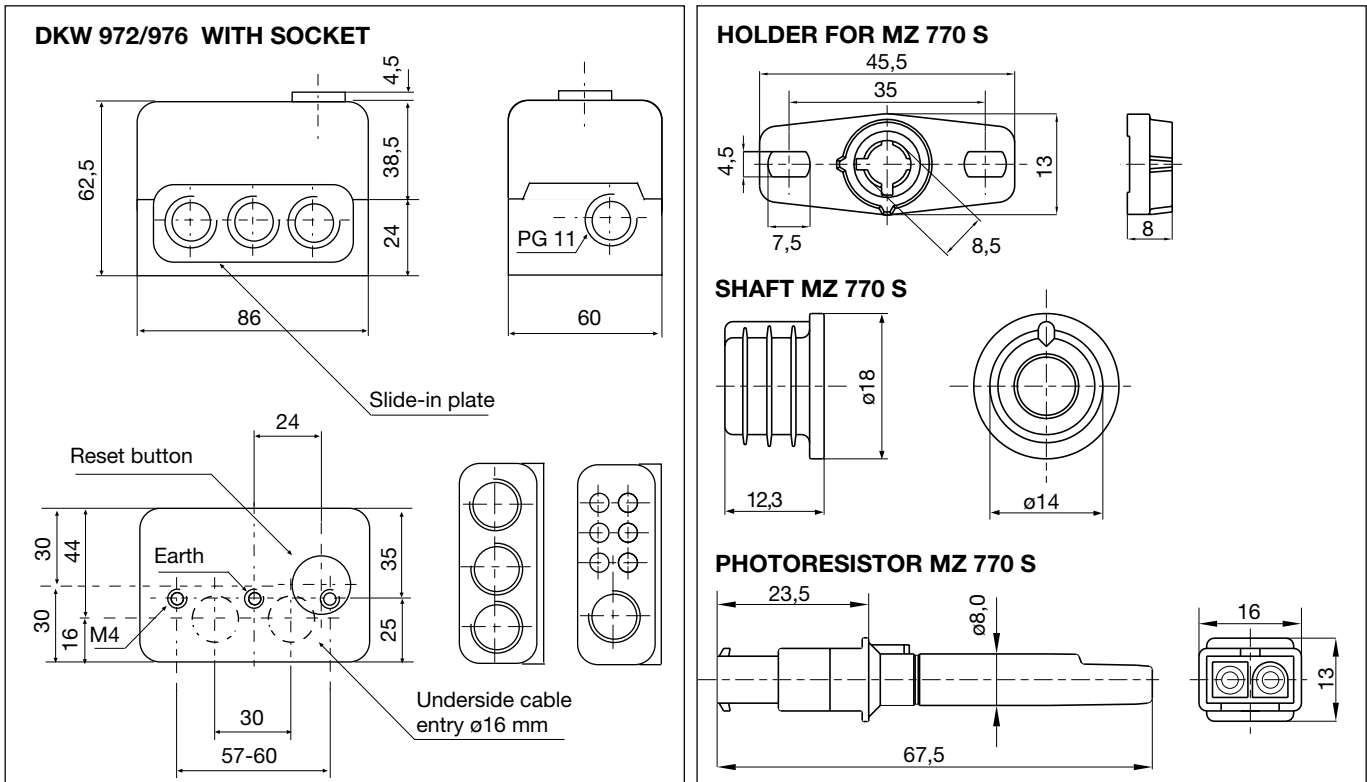

**ORDERING INFORMATION**

ITEM	DESIGNATION	ITEM NO.
Control box	Typ DKW 972 Mod. 05	0322005
or	Typ DKW 976 Mod. 05	0326005
Socket	Wiring base S98 / 12 terminals	75310
Insert plate	PG-Plate	70502
optional	Cable entry plate	70501
Flame detector	MZ 770 S	50001
optional	MZ 770 S with shaft	51001
optional	IRD 1010 right	16501
	IRD 1010 end-on	16502
	IRD 1010 left	16503
optional	UVD 970	16702
Support for flame detector	Holder for MZ 770 S	59101
optional	Holder M 74 for IRD or UVD	59074
Connection cable	Plug type, 3 core cable, 0.6 m with tag wire ends	7236001
Connection cable	Plug type, 2 core cable, 0.5 m with tag wire ends	7225001

The above ordering information refers to the standard version.  
Special versions are also included in our product range.

Specifications subject to change without notice

**DKW 972/976**



A Honeywell Company

Satronic AG  
Brüelstrasse 7  
Postfach 324  
CH-8157 Dielsdorf

## Oil Burner Safety Control

For 1- or 2-stage oil burners up to 30 kg/h throughput and intermittent operations with or without oil preheating facility to connect an air damper motor

### Flame detection:

- Photoresistor MZ 770 S
- Infrared-flicker detector IRD 1010
- UV flame sensor UVD 970

### INTRODUCTION

The DMO 976 oil burner safety control boxes are suitable for oil burners with or without preheater with throughputs up to 30 kg/h. They will be approved and certified according to the applicable European standards and regulations.

The microprocessor-based programming sequence ensures extremely stable timings independent of voltage variations, ambient temperature and/or switch-on cycles. The built-in information system not only provides a continuous monitoring of the actual state of the box (very helpful especially for monitoring the start-up phase) but also informs about the cause of a possible lock out. The lock out cause is stored in such a way that it can be retrieved even after a power failure.

The control box is designed for maximum safety in case of fluctuations in the voltage supply. If the mains voltage drops below the permitted level, operation is interrupted and the control box automatically prevents the start sequence from being repeated. In this way, the safety of the system is not put at risk by a drop in the mains voltage. This low-voltage protection works not only during start-up but also permanently during operation.

### CONSTRUCTIONAL FEATURES

The control box circuitry is protected by a flame resistant, transparent plug-in type plastic housing. A central fixing screw locks the control box to the wiring base.

The plug-in control box incorporates the microprocessor based timer, flame check and reset circuits.

Manual reset from lock out and set to lock out is provided by a push button with an integrated lock out signal lamp.

The wiring base S98 is equipped with spare- and extraterminals and allows together with a variety of cable entry points utmost flexibility of electrical wiring.



### TECHNICAL DATA

Operating voltage	220 / 240 V (-15... +10%) 50 Hz (±5%)
Fuse rating	10 A fast, 6 A slow
Power consumption	ca. 15 VA
Max. load per output	
- term. 3 ignition trafo	1.0 A, cos φ 0.2
- term. 4 motor	2.0 A, cos φ 0.4
- term. 5 + B solenoid valves	1.0 A, cos φ 0.4
- term. 6 oil preheater	2.0 A, cos φ 1.0
- term. 7 alarm indicator	1.0 A, cos φ 0.4
- term. C air damper	1.0 A, cos φ 0.4
total load	4.0 A, cos φ 0.4 max. 10 A during 0.5 sec
Reset time from lock out	none
Flame detectors	< 3 m length of cable
MZ 770 S	side-on and end-on viewing better 6 Lux
Light sensitivity	side-on or end-on viewing
IRD 1010	end-on viewing
UVD 970	
Weight incl. Wiring base	190 g
Mounting position	any
Protection class	IP 40
Approved ambient parameter for control and flame detector	max. 95% bei 30° C
- for operation	0° C... +60° C
- for storage	-20° C... +80° C
Build-up of ice, penetration of water and condensing water are	inadmissible
Approvals according to European standards	EN 230, as well as all other relevant Directives and standards

### Timings (sec.)

Model	waiting time start	max. warm up time oil preheater <b>ta</b>	Pre-purge and pre-ignition time <b>tv1</b>	LK-open command during pre-purge <b>tlk</b>	LK- close movement <b>tr</b>	Stray light monitoring <b>tf</b>	safety time <b>ts</b>	Post-ignition time after V1 <b>tn</b>	delay time terminal B / C <b>tv2</b>
<b>01</b>	0	400	22	17	5	10	5	7	13

## APPLICATION FEATURES

### 1. Information system

The information system is microprocessor based and reports on all aspects of burner control box operation and flame supervision. It informs continuously about the actual programming sequence the unit is just performing. Besides monitoring of the programming sequence it also allows to identify errors during start-up of operation without any additional testing devices. The automatically performed diagnoses is a valuable tool which facilitates service/maintenance work and therefore saves costs. The analyses of the error cause can be done directly on stage or if not possible afterwards as the lock out reason is stored in a non-volatile lock out mode memory.

The information system communicates with the outside world using a LED (the used Flash-Code is similar to the Morse-Code). The messages are optically transmitted by flashing appropriately a LED. Using an (optional) additional terminal the messages can be recorded and displayed in easy readable form.

#### 1.1 Programming sequence display

The built-in microprocessor controls not only the programming sequence but the information system too. The individual phases of the programming sequence are displayed as Flash-Code.

The following messages can be distinguished:

Message	Flash-Code
waiting for control thermostat	.
Pre-purge with air damper open	.
pre-ignition tv1	.
safety time ts post ignition tn	■   .
delay 2nd stage tv2	■     .
running	_
low mains voltage	■ ■ _

#### Description

| = short pulse

■ = long pulse

. = short pause

\_ = long pause

### 1.2 Lock-out diagnoses

In case of a failure the LED is permanently illuminated. Every 10 seconds the illumination is interrupted by a flash code, which indicates the cause of the error. Therefore the following sequence is performed which is repeated as long as the unit is not reset.

Sequence:

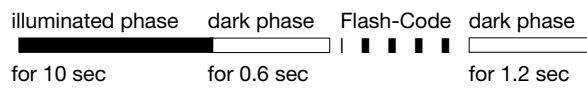

#### Error diagnosis

Error message	Flash-Code	Possible fault
lock out	■ ■ ■ ■	within lock out safety time no flame establishment
stray light	■ ■ ■	stray light during monitored phase, detector may be faulty
limit thermostat time-out	■ ■	contact of limit thermostat does not close within 400 sec.

#### Flash-Code for manual lock out

manual/external lock out	■ ■ ■ _ ■ ■ ■ ■ ■
--------------------------	-------------------

(see also 4. lock out and reset)

## 2. Flame control

The following detectors can be used for flame supervision:

- for yellow oil flame: photoresistor MZ 770 S
- for blue or yellow flame: infrared-flicker detector type IRD 1010 or as an alternative the UV solid state flame sensor UVD 970

Generally, the no flame signal is generated at light levels below 3 Lux with respect to the operating cycle of the control. According to EN 230 stray light safety level has to be established in conjunction with the accompanying burner. Connecting the IRD 1010 or UVD 970, the correct wiring has to be observed.

### 2.1 Stray light monitoring

The stray light check is performed at the end of the pre-purge time for the duration as mentioned in the technical datas.

### 3. Burner control

#### With oil preheater

The fuel heater of the burner has to have a temperature control switch. The closing contact-switch of the heater has to be connected between terminals 4 and 6. A special contact in the control unit connects the thermo-switch of the heater as soon as the burner is operating and a photocurrent is generated. Therefore an interruption of the burner operation due to a decrease in oil temperature is prevented (e.g. in case of high oil flow).

According to EN 230 A 2.1, the short circuiting of the thermostat is allowed only for an oil flow of max. 10 kg/h oil. Burners with a higher throughput have to shut down if the oil temperature gets below the allowed minimum. In such a case the thermo-switch has to be put in the phase-circuit and terminals 4 and 6 have to be connected with a link.

The contact of the release thermostat of the oil preheater is monitored. If the contact does not close within the pre-defined time (400 sec), the programmer goes into lock out mode.

Therefore excessive oil temperatures in the preheater over long periods can be prevented avoiding cracking of the oil and subsequent blocking of the preheater or nozzle.

#### Without oil preheater

In such a case the terminals 4 and 6 have to be connected with a link.



#### Attention

The switch of the release thermostat for the oil preheater must never be linked between 4 and 6 or 6 and 9!

During lockout, the preheater will not be separated from power. This could lead to a defective pre-heater due to burn out its heating winding.

### 4. Lock out and reset

The unit can be reset or brought into lock out mode in two different ways:

#### Internal

In the lock out case the unit can be reset by pushing the built-in button meaning a new start-up cycle is performed.

#### External

Instead of using the built-in lock out button the same function can be achieved by using an external button which connects terminal 9 with A (see also circuit and block diagram).

If the pushbutton (internal or external) is pressed during normal operation or during the start sequence for more than 3 sec. and afterwards released, the control box will perform a shutdown.

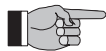

#### Please note

The unit can only be brought to lockout mode or be reset if power is applied to the unit.

### 5. Low-voltage protection

The mains voltage has to be more than  $187 V_{eff}$  in order to allow the unit to perform a start-up.

The mains voltage is not only monitored in the start-up phase but also permanently during operation. If the voltage drops below  $< 160 V_{eff}$  during start-up or run time the control box goes into lock out mode. If the voltage rises again, the control box performs automatically a start-up as soon as the mains voltage is  $> 187 V_{eff}$ .

### 6. Safety

The design and control sequence of the DKO 974/976 controls will comply with the currently applicable standards and regulations (see also TECHNICAL DATA).

### 7. Burner with an air damper motor

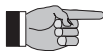

The position of the air damper during pre-purge has to be assured by suitable actions

### 8. Mounting and electrical wiring

Wiring base:

- 3 earth terminals with additional terminal for burner earthing
- 3 neutral terminals with internal permanent connection to neutral terminal 8
- 2 independent spare terminals (S1 and S2)
- extra terminals A, B and C are standard
- 2 slide-in plates and 2 easy knock out holes (PG11 thread) plus 2 knock out holes in the base bottom facilitate the base wiring

The digital controls are ideally wired on the new wiring bases S98, which are equipped with (terminals B and C are only for some special types of DMO or DMG) terminal A, which is used for the remote reset / remote lockout functions.

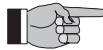

#### Please note

To assist trouble-free operation the main neutral connection terminal in the wiring base must be fully tightened. The terminal screws are already in the undone position. To connect a wire to the terminal, the screw only needs to be fastened.

General: The control box and detector probes should not be subjected to excessive vibration.

## INSTALLATION INSTRUCTIONS AND MAINTENANCE

### 1. Important notes

- The controls must be installed by qualified personnel only. The relevant national regulations have to be observed.
- On commissioning the wiring has to be carefully checked according to the appropriate diagram. Incorrect wiring can damage the unit and endanger the installation.
- The fuse rating has to ensure that the limits specified in TECHNICAL DATA will not be exceeded. If these precautions are not observed, the effect of a short circuit can cause severe damage to the control and installation.
- For safety reasons a minimum of one control shutdown per 24 hours has to be observed.
- Disconnect the mains before the control box is plugged in or out.
- The control box is a safety device and must not be opened!

### 2. Function control

For safety reasons the flame detection system should be tested on commissioning the installation as well as after a service or longer shut-down.

- Start-up with covered flame detector
  - After lock out safety time is over the unit has to go into lock out mode!
- Start-up with exposed flame detector
  - After 12 sec prepurge time the unit has to go into lock out mode!
- Normal start-up with burner in the normal position, cover up the flame detector
  - After start-up, and end of lock out safety time the unit has to go into lock out mode!

### 3. Fault finding

The built-in information system facilitates the trouble shooting in the case of problems occurring during start-up or during operation.

A list of possible lock out messages can be found in APPLICATION FEATURES chapter 1.2.

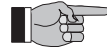

#### Please note:

**The control box is locked in lock out mode and the reason for the lock out is displayed until the control box is reset, either by an internal or external reset (see also subject "3. Lock out and reset").**

Removing the control box from its wiring base or by interrupting the supply line may not reset a lock out (according to EN 230). Therefore, by applying power, the fan motor/nozzle preheater switches on for 2-3 secs. before the control box goes to lock out again and the cause of the last lock out.

Error	Possible fault
Burner not working	- Thermostat circuit open - Faulty electrical wiring - Oil preheater defective - mains voltage < 187 V
Fan motor/nozzle preheater starts for a short period of time, control box goes to lock out	- Control box has not been reset
Burner starts, flame not established, lock out	- Stray light on flame detector - No ignition or no fuel
Burner starts, flame established, after safety time, lock out	- Dirty or faulty flame detector - Insufficient light on detector - Sensitivity adjustment too low on IRD

**CIRCUIT AND TIMING DIAGRAM DMO 976  
WITH AIR DAMPER MOTOR**

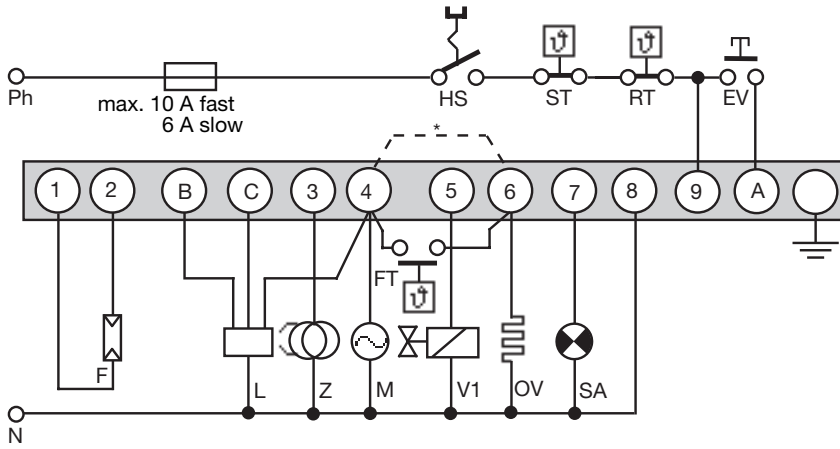

- HS Mains switch
  - ST Limit thermostat
  - RT Control thermostat
  - EV External reset and lock out button
  - F Flame detector MZ 770 S (IRD 1010, UVD 970 see separate diagram)
  - Z Ignition
  - M Burner motor
  - V1, V2 Oil solenoid valve
  - OV Oil preheater
  - FT Release thermostat oil preheater
  - \* For burners without fuel heaters term. 4 and 6 have to be connected with a link
  - SA External lock out signal
  - L Air damper motor
- 
- ta Pre-heat-time oil preheater
  - tv1 Pre-purge and pre-ignition time
  - tlk LK-open command during pre-purge
  - tr LK-close movement
  - tf stray light monitoring
  - ts Lock out safety time
  - tn Post-ignition time
  - tv2 Delay terminal 6

**WITHOUT AIR DAMPER MOTOR**

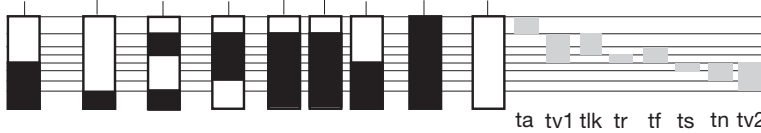
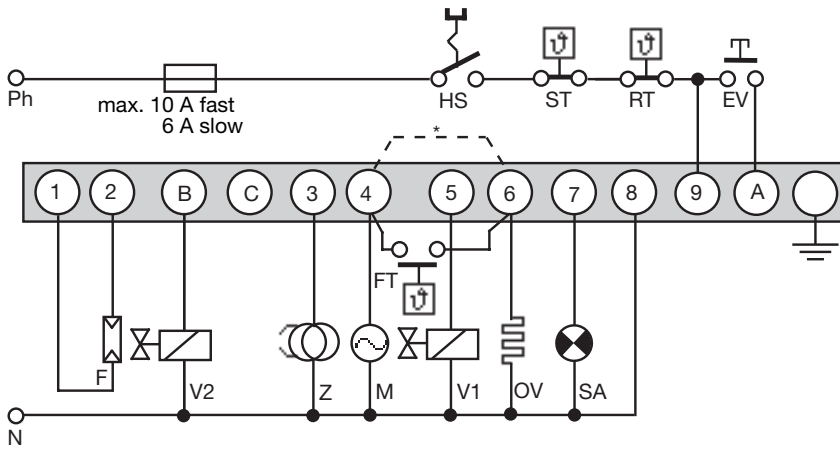

**IRD-/UVD-CONNECTION**

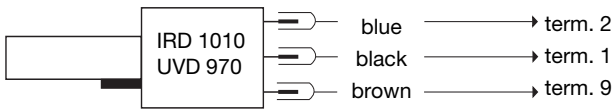

**BLOCK DIAGRAM DMO 976**

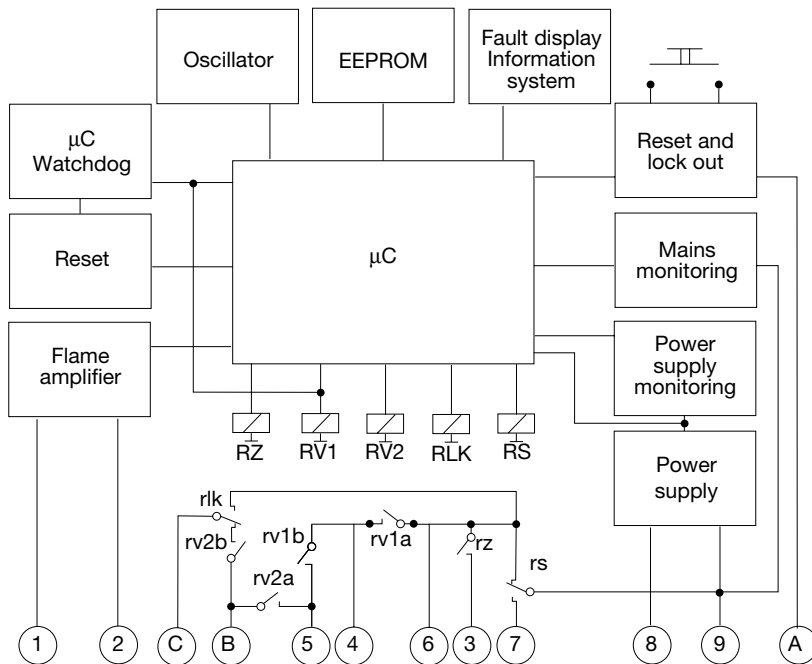

DMO 976

### DKO 974/976 AND SOCKET

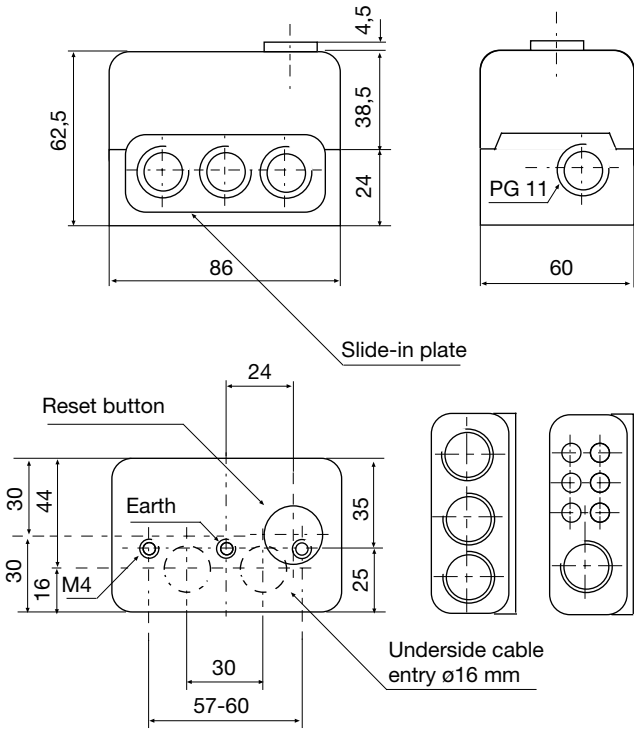

### HOLDER FOR MZ 770 S

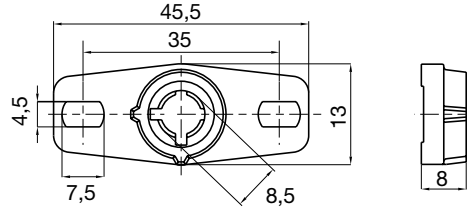

### SHAFT MZ 770 S

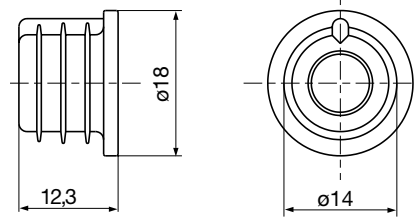

### PHOTORESISTOR MZ 770 S

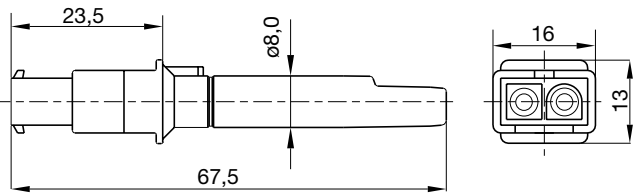

### UVD 970

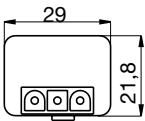

### IRD 1010

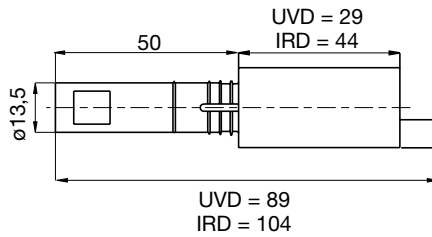
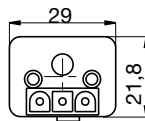

### HOLDER M74 FOR IRD OR UVD

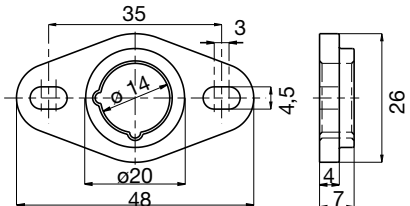

### VARIATION IRD

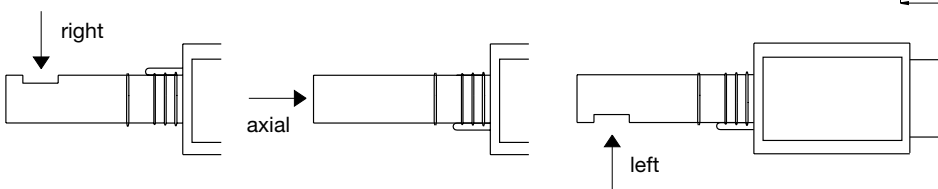

### ORDERING INFORMATION

ITEM	DESIGNATION	ITEM NO.
Control box	DMO 976 Mod. 01	0346001
Socket	Wiring base S98	75310
Insert plate	PG-Plate	70502
optional	Cable entry plate	70501
Flame detector	MZ 770 S	50001
optional	MZ 770 S with shaft	51001
optional	IRD 1010 right	16501
	IRD 1010 end-on	16502
	IRD 1010 left	16503
optional	UVD 970	16702
Support for flame detector	Holder for MZ 770 S	59101
optional	Holder M 74 for IRD or UVD	59074
Connection cable	Plug type, 3 core cable, 0.6 m with tag wire ends	7236001
Connection cable	Plug type, 2 core cable, 0.5 m with tag wire ends	7225001

The above ordering information refers to the standard version.  
Special versions are also included in our product range.

Specifications subject to change without notice

# DMO 976

A Honeywell Company

Satronic AG  
Brüelstrasse 7  
Postfach 324  
CH-8157 Dielsdorf

## Gas Burner Control Box

**For 2-stage atmospheric gas burners**

**Possible flame detectors:**  
 - Ionisation probe  
 - Infra-red flicker detector

### INTRODUCTION

The TFI 812.2 gas burner control boxes are capable of controlling and monitoring atmospheric gas burners. They have been tested and approved as per DIN 4788 part 3 edition 04.89 and with the European standard EN 298. They are also suitable for use with stationary warm air generators (as per DIN 4794).

The control boxes are designed for maximum safety in case of fluctuations in the voltage supply. If the mains voltage drops below the permitted level, operation is interrupted and the control box automatically prevents the start sequence from being repeated. In this way, the safety of the system is not put at risk by a drop in the mains voltage.

The control box and the monitoring function which it performs is not negatively affected by occasional stray ignition sparks jumping to the ionisation electrode.

The FR 870 remote reset (item no. 70700) can be connected, and allows remote reset of the control box (see doc. no. 750).

The TFI 812 mod.5 can be installed in place of the TFI 712 F, and the TFI 812 mod.10 can be employed to replace the TFI 712.

It is not necessary to rewire or replace the baseplate. The difference in the heights of the units can be compensated by attaching the reset button extension (item no. 70601).

The difference between the TFI 812.1 and the TFI 812.2 is that the TFI 812.2 control boxes are equipped with the voltage drop fail-safe function. Otherwise, they are identical in terms of operation and possible applications.

### CONSTRUCTIONAL FEATURES

The control box is well protected by a flame-resistant, transparent, plug-in type plastic housing which encloses the thermo-mechanical temperature-compensated timing unit, the flame monitoring unit and the reset device.

The reset button, which incorporates an indicator lamp, and the central screw fastening, are situated on the upper part of the control box.

The baseplate, which can be equipped with additional terminals, together with the various optional cable entry points, makes universal wiring possible.



### TYPES AVAILABLE

TFI 812.2 mod. 5	Safety interval 5 sec. Pre-ignition time approx. 15 sec. appropriate nominal capacity according to the appliance standort or the gas appliance directive.
TFI 812.2 mod. 10	Safety interval 10 sec. Pre-ignition time approx. 10 sec. appropriate nominal capacity according to the appliance standort or the gas appliance directive.
TFI 812.2 B mod. 5	dito – without Pre-ignition time
TFI 812.2 B mod. 10	dito – without Pre-ignition time

### TECHNICAL DATA

Supply voltage	220/240 V (-15... +10%) 50 Hz (40 - 60 Hz)
Fuse rating	10 A rapid or 6 A slow
Power consumption	5 VA
Max. current per output terminal	4 A
Max. current total	6 A
Pre-ignition time	15 or 10 sec.
Delay, post-ignition time	none
Safety interval	5 or 10 sec.
2nd stage delay	approx. 20 sec.
Reset delay after lockout	approx. 60 sec.
Permissible ambient temperature	-20° C to +60° C
Sensitivity	1.5 µA
Min. ionisation current required	2 - 3 µA
Ionisation probe insulation	probe - earth greater than 50 MΩ
Stray capacitance	probe - earth less than 1000 pF (max. 20 m cable)
Insulation standard	IP 44
Weight incl. baseplate	250 g
Mounting attitude	any

## TECHNICAL FEATURES

### 1. Flame detection

The following types of flame detectors are suitable:

- Ionisation probe, temperature resistant material, well insulated (material and insulation same as for ignition electrode).
- IRD 1020 infra-red flicker detector (see doc. 746)

Flame detection using an ionisation probe is only possible in conjunction with mains supplies which provide a neutral earth connection.

### 2. Safety

In terms of design/construction and programme sequence, the TFI 812 control boxes conform to the presently applicable European standards and regulations.

### 3. Installation

At the baseplate:

- 3 earth terminals, with an additional tag for the burner earth.
- 3 neutral terminals, with a fixed, internal through connection to the neutral input, terminal 8.
- 2 independent terminals, which can be used as desired.
- 2 separate slide-in plates and 2 fixed, threaded knock-outs (PG 11 thread) as well as 2 knock-outs underneath, facilitate wiring of the baseplate.

General:

- Can be mounted in any position, insulated as per IP 44 standard (unaffected by water spray).  
The control box and detector probe should not, however, be subjected to excessive vibration.
- The applicable installation regulations must be observed during installation.

## COMMISSIONING AND MAINTENANCE

### 1. Important notes

- The wiring must be checked exactly when commissioning the installation. Incorrect wiring could damage the control box, putting the safety of the burner system at risk.
- The chosen fuse rating must not, on any account, be higher than the value given in the technical data. Failure to observe this instruction could, in the case of a short circuit, have serious consequences for the control box or burner system.
- For safety reasons, it must be ensured that the control box performs at least one normal shut-down during every 24 hour period.
- Switch off or disconnect the power before plugging in or unplugging the unit.
- Burner control boxes are responsible for the safety of the system and should not be opened.

### 2. Routine checks

On commissioning or after servicing the burner system, or if the system has not been in operation for a long period, a check of the safety-relevant control box functions must be made.

- a) Attempt to start with gas valve closed:
  - At the end of the safety interval  
-> Lockout
- b) After a normal start, with the burner in operation, close the gas valve:
  - At the end of the safety interval, system attempts to restart  
-> Lockout

### 3. Possible faults

Burner does not start:

- Fault in electrical supply, thermostat OFF
- Mains voltage too low

Switches to lockout after attempted start without establishing flame:

- No ignition or no fuel reaching burner
- Flame signal during the pre-purge phase
- Mains voltage more than 15% below nominal value

Burner starts, flame is established but control box switches to lockout after elapse of safety interval:

- No flame signal or signal too weak
- Flame detector dirty or defective

**WIRING AND SEQUENCE DIAGRAMS TFI 812.2**

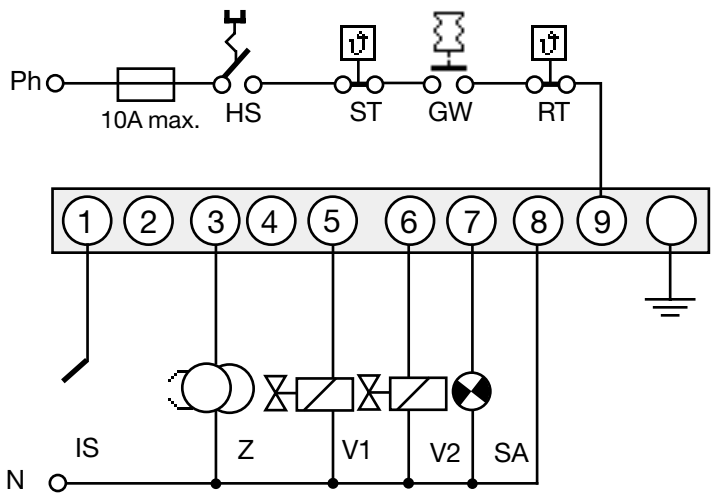

- HS Main switch
  - GW Gas proving switch
  - ST Safety thermostat
  - RT Controlling thermostat
  - IS Ionisation probe
  - Z Ignition
  - V1 Solenoid valve, 1st stage
  - V2 Solenoid valve, 2nd stage
  - SA remote lockout indicator
- 
- tw Pre-ignition time  
approx. 15 sec. (mod. 5)
  - ts Safety time 5 sec. (mod. 5)  
10 sec. (mod. 10)
  - tv2 2nd stage delay approx. 20 sec.

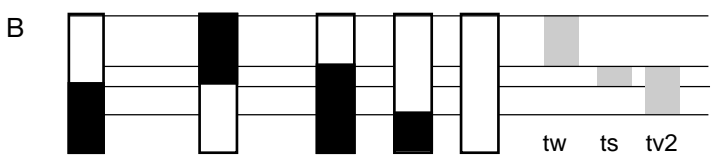

**IRD CONNECTION**

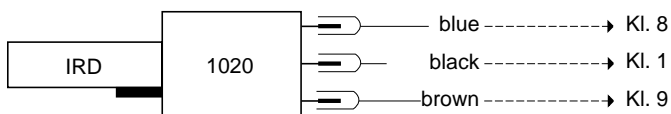

**GENERAL CIRCUIT DIAGRAM TFI 812.2**

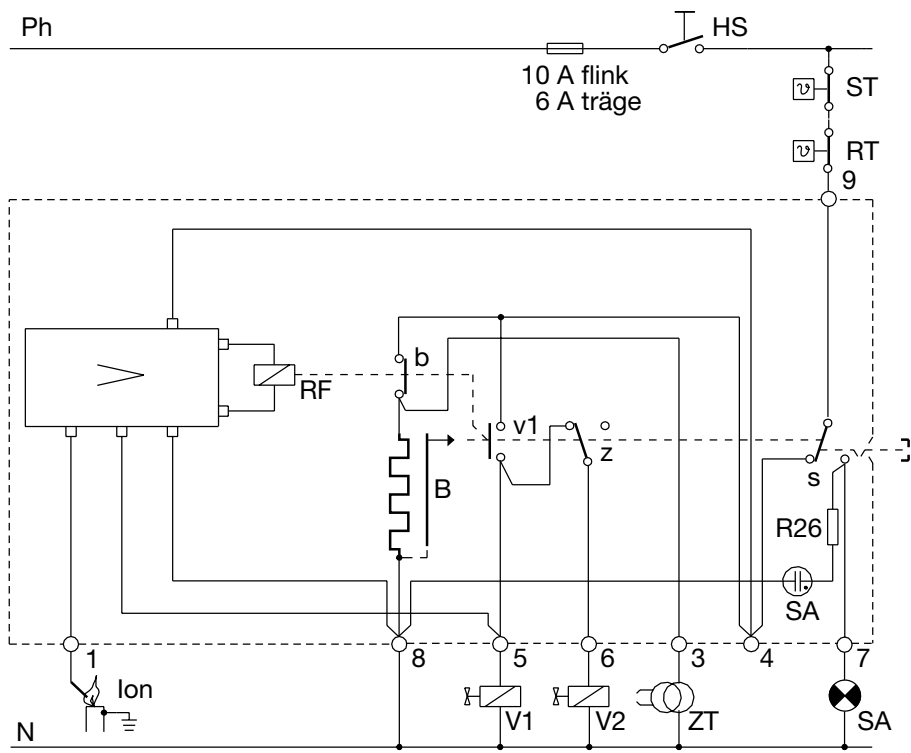

- HS Main switch
- RT Controlling thermostat
- B Thermal timing unit
- R26 Resistor
- Ion Ionisation probe
- ZT Ignition
- ST Safety thermostat
- RF Flame relay
- V1 Valve1
- V2 Valve 2
- SA Lockout indicator
- > Amplifier IV7

### DIMENSIONS WITH BASEPLATE TFI 812

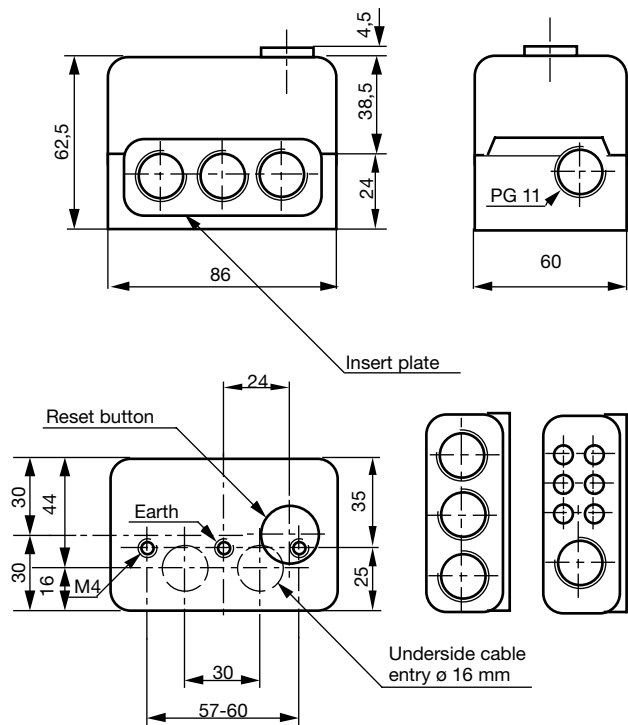

### MEASUREMENT OF THE FLAME SIGNAL

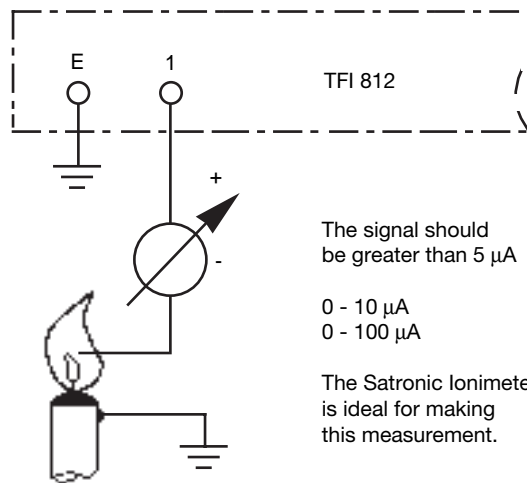

### IRD 1020

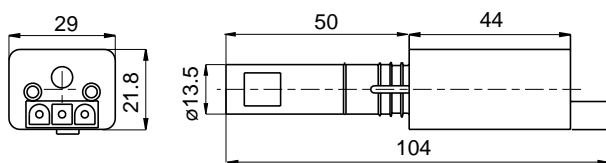

### HOLDER M93

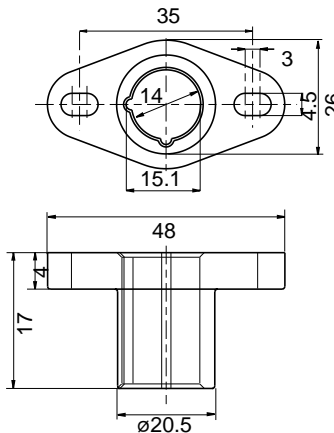

### ORDERING INFORMATION

ITEM	DESIGNATION	ITEM NO.
Control box	TFI 812.2 mod. 5	02601
Control box	TFI 812.2 mod. 10	02602
Control box	TFI 812.2 B mod. 5	02607
Control box	TFI 812.2 B mod. 10	02608
Base	701 ABEN base	70001
Insert plate	PG plate	70502
optionally	Cable entry plate	70501
Flame detector	IRD 1020 end-on viewing	16522
Flame detector	IRD 1020 side-on left	16523
Flame detector	IRD 1020 side-on right	16521
IRD mounting flange	IRD Holder M93	59093
Flame detector cable	3-wire, 0.6 m	7236001

The above ordering information refers to the standard version. Special versions are also included in our product range.

Specifications subject to change without notice.

# TFI 812

**satronic**  
A Honeywell Company

Satronic AG  
Brüelstrasse 7  
Postfach 324  
CH-8157 Dielsdorf

## Gas burner automatic safety control

**For 2-stage forced draught and combi oil/ gas burners**

**Possible flame detectors:**

- Ionization probe
- Infrared flicker detector

### INTRODUCTION

The gas burner automatic safety control MMI controls and monitors blown gas- and combined burners of any nominal thermal load (tested and certified according to EN 298).

The automatic safety controls MMI 810.1 models 13, 33 and 35 can also be utilized for burners on fixed hot air heaters (Direct air heaters according to DIN 4794).

Various types and model designations differentiate the automatic safety controls with respect to the programme times, as well as with regard to differing national standards.

### TYPES AVAILABLE

MMI 810.1	Mod. 13 *	Art. Nr. 0620720
	Mod. 33	Art. Nr. 0620220
	Mod. 35	Art. Nr. 0620920
	Mod. 43	Art. Nr. 0622520
	Mod. 55	Art. Nr. 0621320
MMI 811.1	Mod. 35	Art. Nr. 0621120
	Mod. 63	Art. Nr. 0620420

\* Must only be used on boilers or other applications where the 10 second pre-purge time is sufficient to provide at least 3 volume changes of the combustion chamber.

### CONSTRUCTIONAL FEATURES

The automatic control is housed in a non-inflammable, transparent, plug-in type plastic case and contains:

- Synchronous motor with speed reducer gears as the drive for the switching cam
- Switching cam with informative programme display in colour
- 12 times cam drive for controlling the programme sequence
- Plug-in type circuit boards with the electronic components

The following important indicating - and operating elements are located on the front panel of the automatic control:

- Illuminated pushbutton for indication of malfunctions and reset
- Programme display in colour
- Screw for central mounting



### TECHNICAL DATA

Operating voltage	220 / 240 V (-15... +10%)
Differing frequency	50 Hz (50 - 60 Hz) Results in a proportional deviation of the time.
Rating fuse	max. 10 A rapid, 6 A slow
Power consumption	10 VA
Max. load per output:	
- term. 3	2A, cos φ 0.2
- term. 4, B	2A, cos φ 0.4
- term. 5, 6	1A, cos φ 0.4
total load	5A, cos φ 0.4
Amplifier sensitivity	1 μA
Minimum required ionization current	5 μA
Flame detector cable	max. 20 m cable length
Air pressure monitor	working contact 4 A, 230 V
Waiting time for malfunction remedy	None
Flame detector	
- Ionization probe	
- Infrared flicker detector	IRD 1020
Weight, incl. base	350 g
Mounting position	any
Insulation standard	IP 44
Admissible ambient temperature for controller and flame detector	-20° C... +60° C
Classified acc. to EN 298	BTLXN

program	MMI 810.1					811.1	
	13	33	35	43	55	35	63
timings (sec.)							
Modell							
Waiting time at start ca.	6	9	9	9	9	9	6
Max. reaction time for air proving switch	3.5	6	6	6	17	6	5
Pre-purge time	3	24	24	40	20	24	55
Pre-ignition time	2	3	3	3	15	3	3
T. ignition time	5	6	8	6	20	8	5.5
Safety time	3	3	5	3	5	5	3
Time delay term.6/term.C	6	10	10	10	10	10	6

For external resetting, the remote reset device FR 870 (art. No. 70700) can be utilized. (Refer to doc. 750).

## APPLICATION TECHNOLOGY FEATURES

### 1. Flame Monitoring

The flame monitoring can be effected with the following flame detectors:

- With ionization electrodes in power grids with earthed neutral conductor, utilizable with gas burners (interference effects of the ignition spark cannot influence the formation of the flame signal).
- With infrared flicker detector type IRD 1020 for all types of burners.

### 2. Burner Control

- The burner controls features a low-voltage protection. If the supply voltage drops below 160 V during operation, the burner switches-off. When the supply voltage raises above 180 V, the burner performs a restart independently.
- The automatic burner controls MMI only operate, when a load is connected to terminal 5. If the fuel valve is interrupted by an external contact during the pre-purging phase, a resistance of max. 22 kW, 4 Watt has to be applied between the terminals 5 and 8.
- Functional test of the air pressure monitor before the startup and monitoring of the air pressure during the pre-purging time, as well as in the operating condition of the burner. For normal applications a working contact with a power rating of 4 A / 230 V is sufficient.
- In the case of the automatic control MMI 810.1, contacts can be installed between the terminals 1 and 9 (e.g., valve limit position contacts). These are checked for their correct closing position when the unit is started up. The connection 1 - 9 has to be closed during the starting phase of the automatic control.

### 3. Safety

With respect to design and programme sequence, the gas burner automatic safety controls of the MMI type range comply with the currently applicable European standards and regulations.

### 4. Mounting and Electrical Installation

On the base:

- 3 earth conductor terminals with additional strap for the earthing of the burner.
- 3 neutral conductor terminals with an internal, fixed connection to the neutral conductor input, terminal 8.
- 2 individual slide-in plates and 2 fixed knock-out apertures with thread PG 11, as well as 2 knock-out apertures from below, make the wiring of the base more easy.

General:

- Mounting position as required, insulation standard IP 44 (splash-proof). The automatic control and sensor should, however, not be exposed to excessive vibration.
- During mounting and installation, the applicable regulations for installation have to be observed.

## COMMISSIONING AND SERVICE/MAINTENANCE

### 1. Important Remarks

- Before commissioning, the wiring has to be accurately checked. Faulty wiring can damage the unit and endanger the safety of the installation.
- The mains fuse has to be selected so that the limit values indicated under "Technical Specifications" are under no circumstances exceeded. Non-compliance with this regulation can have very serious consequences for the control unit and for the installation in the case of a short-circuit.
- For safety reasons, at least one control shut-down per 24 hours must be assured.
- The control unit must be plugged-in or -out only when the mains supply has been disconnected.
- Automatic burner safety controls are safety devices and must not be opened.

### 2. Functional Check

During commissioning and after an overhaul of the burner, the following checks have to be carried out:

- a) Starting test with closed manual valve and bridged gas monitor contact:
  - The device must go into a fault condition after the safety period has elapsed.
- b) Close the manual valve in operating position with the gas monitor contact bridged.
  - The device must go into a fault condition after a flame failure.
- c) Air pressure monitor contact interrupted:
  - Device goes into a fault condition.
- d) Bridge air pressure monitor contact before starting:
  - Device must not start.

### 3. Trouble Shooting

Burner does not go into operation, programme indication remains:

- Electrical connection defective.
- Thermostat or gas monitor "OFF".

Burner does not go into operation, programme indication rotates continuously:

- Air pressure monitor defective, respectively, not in starting position. (Working contact must be open).
- Connection term. 1 - term. 9 interrupted
- mains voltage < 180V

The automatic control switches to fault condition shortly after the start of the pre-purge time (line within the blue zone):

- Air pressure monitor contact does not close.
- No load on terminal 5.
- Flame signal.

Automatic control switches to fault condition during the pre-purging (blue zone):

- No flame formation (ignition missing, valve does not open, etc.)
- No flame signal or too weak flame signal (flame does not adhere, poor insulation of the flame detector, burner not properly connected to the earth conductor).

Automatic control switches to fault condition during the operating position (red, resp. green zone):

- Flame lift-off
- Air pressure monitor contact opens
- Flame signal too weak.

**SCHEMATIC CONNECTION DIAGRAM AND PROCESS DIAGRAM MMI 810.1**

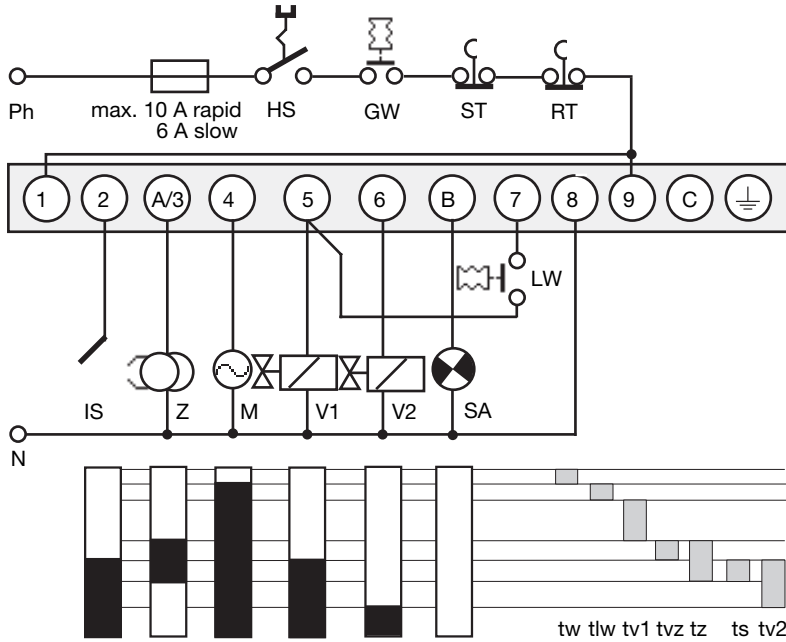

- HS Main switch
- GW Gas pressure switch
- ST Limit thermostat
- RT Control thermostat
- IS Ionization probe
- Z Ignition
- M Burner motor
- V1 Solenoid valve 1st stage
- V2 Solenoid valve 2nd stage
- LW Air pressure monitor
- SA External fault indication
- SV Safety valve

**SCHEMATIC CONNECTION DIAGRAM AND PROCESS DIAGRAM MMI 811.1**

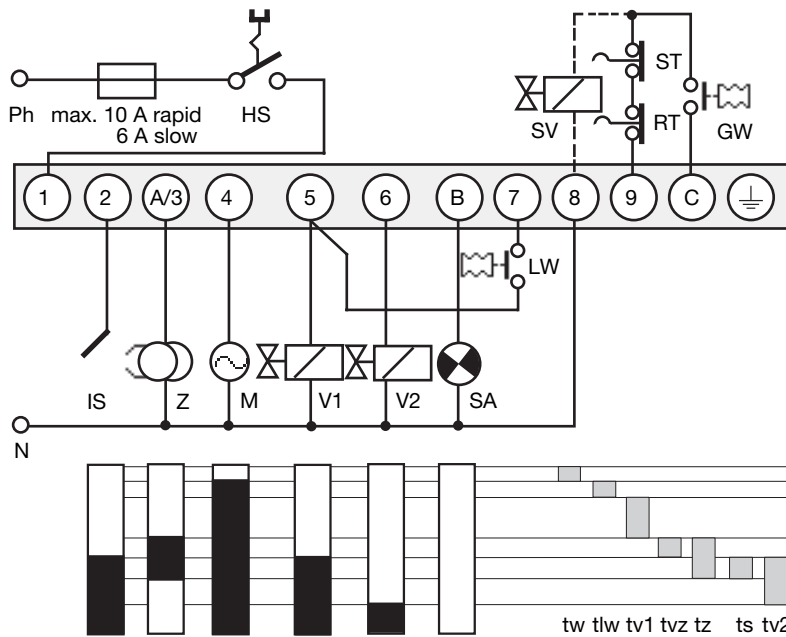

- tw Waiting time at start-up
- tlw Max. reaction time for air proving switch
- tv1 Pre-purge time
- tvz Pre-ignition time
- tz Total ignition time
- ts Safety time
- tv2 Time delay term.6 / term.C

**IRD CONNECTION**

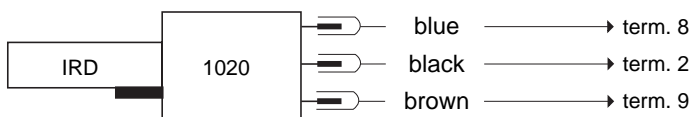

**SCHEMATIC DIAGRAM MMI 810.1**

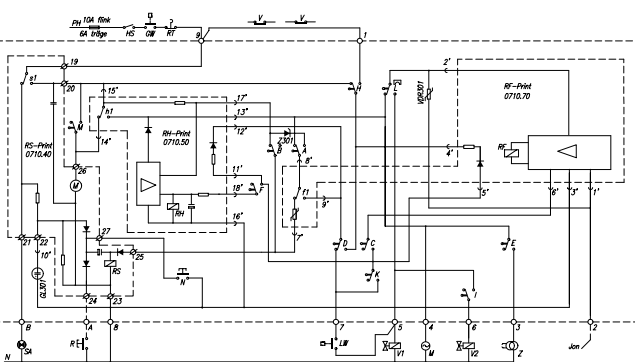

**SCHEMATIC DIAGRAM MMI 811.1**

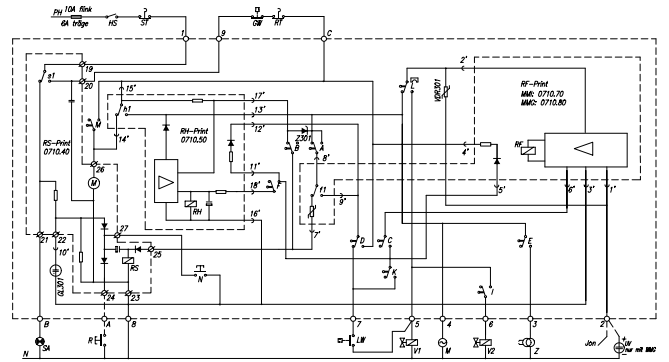

### MMI WITH BASE

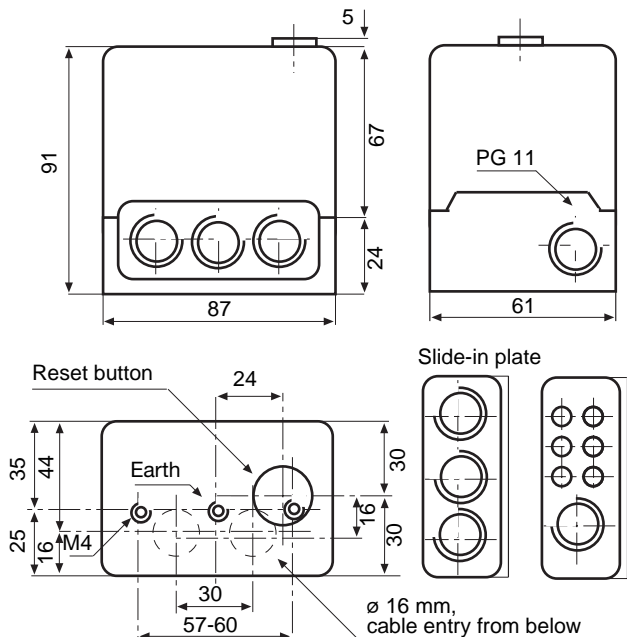

### MEASUREMENT OF THE FLAME SIGNAL

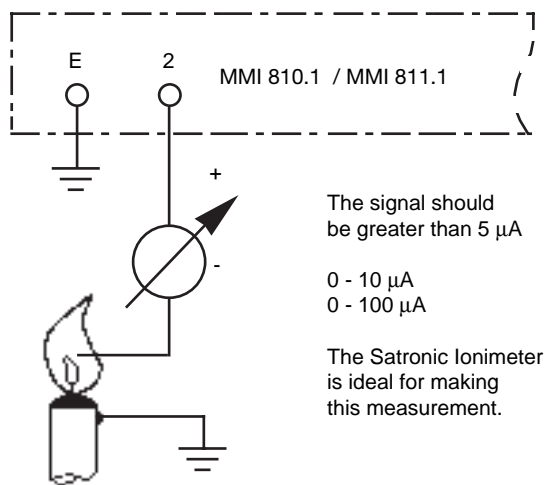

The signal should be greater than 5  $\mu$ A

0 - 10  $\mu$ A  
0 - 100  $\mu$ A

The Satronic Ionimeter is ideal for making this measurement.

### IRD 1020

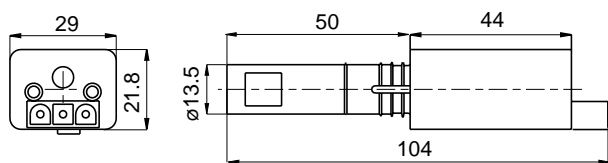

### HOLDER M93

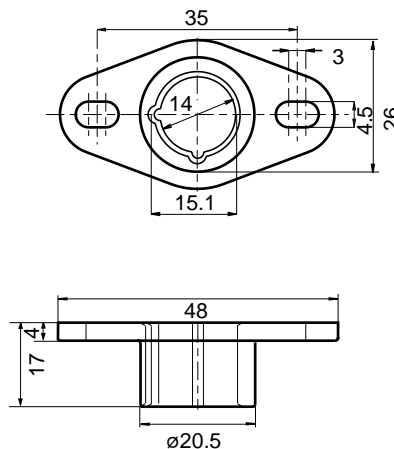

### ORDERING INFORMATION

ITEM	DESIGNATION	ITEM NO.
Control unit	Type MMI 810.1 mod. 33	0620220
or	Type MMI 811.1 mod. 35	0621120
Base for MMI 810.1	Base 701 TTG-EN	70101
Base for MMI 811.1	Base 710 TTG-FN	70102
Slide-in plate	PG-plate	70502
optionally	Cable clamping plate	70501
Flame detector	IRD 1020 end-on viewing	16522
Flame detector	IRD 1020 side-on left	16523
Flame detector	IRD 1020 side-on right	16521
IRD mounting flange	IRD Holder M93	59093
Flame detector cable	3-wire, 0.6 m	7236001

The above ordering information refers to the standard version. Special versions are also included in our product range.

Specifications subject to change without notice.

# MMI 810.1 / 811.1

A Honeywell Company

Satronic AG  
Brüelstrasse 7  
Postfach 324  
CH-8157 Dielsdorf

## MMI 812

# Gas burner automatic safety control

**For 2-stage forced draught gas burners  
 Facility to connect an air damper unit**

**Possible flame detectors:**

- Ionization probe
- Infrared flicker detector

## INTRODUCTION

The gas burner automatic safety control MMI 812 controls and monitors blown gas- and combined burners of any nominal thermal load (tested and certified according to EN 298).

If an air damper unit is connected, a 2-stage operation with two fuel valves or a modulating operation with one fuel valve is possible.

Various types and model designations differentiate the automatic safety controls with respect to the programme times, as well as with regard to differing national standards.

## TYPES AVAILABLE

MMI 812.1	Modell 23	Art. Nr. 06223
MMI 812	Modell 33	Art. Nr. 06205

## CONSTRUCTIONAL FEATURES

The automatic control is housed in a non-inflammable, transparent, plug-in type plastic case and contains:

- Synchronous motor with speed reducer gears as the drive for the switching cam
- Switching cam with informative programme display in colour
- 10 times cam drive for controlling the programme sequence
- Plug-in type circuit boards with the electronic components

The following important indicating - and operating elements are located on the front panel of the automatic control:

- Illuminated pushbutton for indication of malfunctions and reset
- Programme display in colour
- Screw for central mounting



## TECHNICAL DATA

Operating voltage	220 / 240 V (-15... +10%) 50 Hz (40 - 60 Hz)
Differing frequency	Results in a proportional deviation of the time.
Rating fuse	max. 10 A rapid, 6 A slow
Power consumption	10 VA
Max. load per output	4 A
Overall	6 A
Amplifier sensitivity	1 $\mu$ A
Minimum required ionization current	5 $\mu$ A
Flame detector cable	max. 20 m cable length
Air pressure monitor	1 working contact 4 A, 230 V
Waiting time for malfunction remedy	None
Flame detector	
- Ionization probe	
- Infrared flicker detector	IRD 1020
Weight, incl. base	350 g
Mounting position	Any
Insulation standard	IP 44
Admissible ambient temperature for controller and flame detector	-20° C... +60° C
Classified acc. to EN 298	BTLLXN

program timings (sec.)		MMI 812.1	MMI 812
Modell		23	33
Waiting time at start-up	tw	8	5
Max. reaction time for air proving switch	tlw	15	18
Pre-purge time	tv1	30	42
LK open signal	tlk	36	49
Pre-ignition time	tvz	3	3
Total ignition time	tz	5.5	5.5
Safety time	ts	3	3
Time delay term.6 / term.C	tv2	6	6

For external resetting, the remote reset device FR 870 (art. No. 70700) can be utilized. (Refer to doc. 750).

## APPLICATION TECHNOLOGY FEATURES

### 1. Flame Monitoring

The flame monitoring can be effected with the following flame detectors:

- With ionization electrodes in power grids with earthed neutral conductor, utilizable with gas burners (interference effects of the ignition spark cannot influence the formation of the flame signal).
- With infrared flicker detector type IRD 1020 for all types of burners.

### 2. Burner Control

- The automatic burner controls MMI only operate, when a load is connected to terminal 5. If the fuel valve is interrupted by an external contact during the pre-purging phase, a resistance of max. 22 k $\Omega$ , 4 Watt has to be applied between the terminals 5 and 8.
- Functional test of the air pressure monitor before the startup and monitoring of the air pressure during the pre-purging time, as well as in the operating condition of the burner. For normal applications a working contact with a power rating of 4 A / 230 V is sufficient.
- In the case of the automatic control MMI 810, contacts can be installed between the terminals 1 and 9 (e.g., valve limit position contacts). These are checked for their correct closing position when the unit is started up. The connection 1 - 9 has to be closed during the starting phase of the automatic control.
- No fuel valve must be connected to terminal 6.

### 3. Safety

With respect to design and programme sequence, the gas burner automatic safety controls of the MMI type range comply with the currently applicable European standards and regulations.

### 4. Mounting and Electrical Installation

On the base:

- 3 earth conductor terminals with additional strap for the earthing of the burner.
- 3 neutral conductor terminals with an internal, fixed connection to the neutral conductor input, terminal 8.
- 2 individual slide-in plates and 2 fixed knock-out apertures with thread PG 11, as well as 2 knock-out apertures from below, make the wiring of the base more easy.

General:

- Mounting position as required, insulation standard IP 44 (splash-proof). The automatic control and sensor should, however, not be exposed to excessive vibration.
- During mounting and installation, the applicable regulations for installation have to be observed.

## COMMISSIONING AND SERVICE/MAINTENANCE

### 1. Important Remarks

- Before commissioning, the wiring has to be accurately checked. Faulty wiring can damage the unit and endanger the safety of the installation.
- The mains fuse has to be selected so that the limit values indicated under "Technical Specifications" are under no circumstances exceeded. Non-compliance with this regulation can have very serious consequences for the control unit and for the installation in the case of a short-circuit.
- For safety reasons, at least one control shut-down per 24 hours must be assured.
- The control unit must be plugged-in or -out only when the mains supply has been disconnected.
- Automatic burner safety controls are safety devices and must not be opened.

### 2. Functional Check

During commissioning and after an overhaul of the burner, the following checks have to be carried out:

- Starting test with closed manual valve and bridged gas monitor contact:
  - The device must go into a fault condition after the safety period has elapsed.
- Close the manual valve in operating position with the gas monitor contact bridged.
  - The device must go into a fault condition after a flame failure.
- Air pressure monitor contact interrupted:
  - Device goes into a fault condition.
- Bridge air pressure monitor contact before starting:
  - Device must not start.

### 3. Trouble Shooting

Burner does not go into operation, programme indication remains:

- Electrical connection defective.
- Thermostat or gas monitor "OFF".

Burner does not go into operation, programme indication rotates continuously:

- Air pressure monitor defective, respectively, not in starting position. (Working contact must be open).

The automatic control switches to fault condition shortly after the start of the pre-purge time (line within the blue zone):

- Air pressure monitor contact does not close.
- No load on terminal 5.
- Flame signal.

Automatic control switches to fault condition during the pre-purging (blue zone):

- No flame formation (ignition missing, valve does not open, etc.)
- No flame signal or too weak flame signal (flame does not adhere, poor insulation of the flame detector, burner not properly connected to the earth conductor).

Automatic control switches to fault condition during the operating position (red, resp. green zone):

- Flame lift-off
- Air pressure monitor contact opens
- Flame signal too weak.

# SCHEMATIC CONNECTION DIAGRAM AND PROCESS DIAGRAM MMI 812

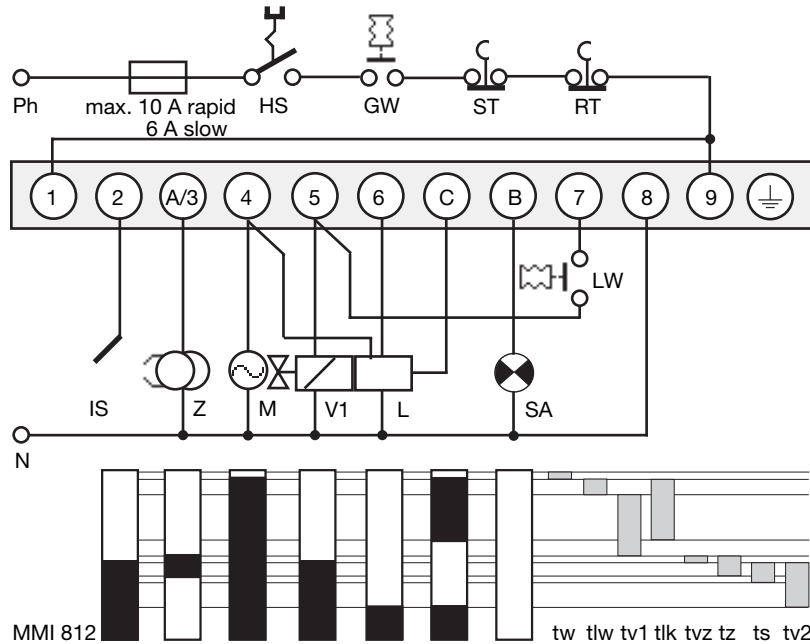

- HS Main switch
- GW Gas pressure switch
- ST Limit thermostat
- RT Control thermostat
- IS Ionization probe
- Z Ignition
- M Burner motor
- V1 Solenoid valve 1st stage
- L Air damper unit
- LW Air pressure monitor
- SA External fault indication
  
- tw Waiting time at start-up
- tlw Max. reaction time for air proving switch
- tv1 Pre-purge time
- tlk LK open signal
- tvz Pre-ignition time
- tz Total ignition time
- ts Safety time
- tv2 Time delay term.6 / term.C

## IRD CONNECTION

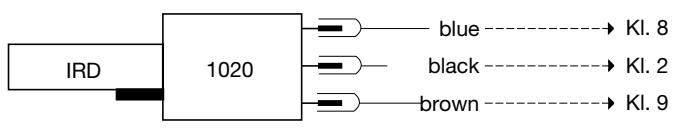

## SCHEMATIC DIAGRAM MMI 812

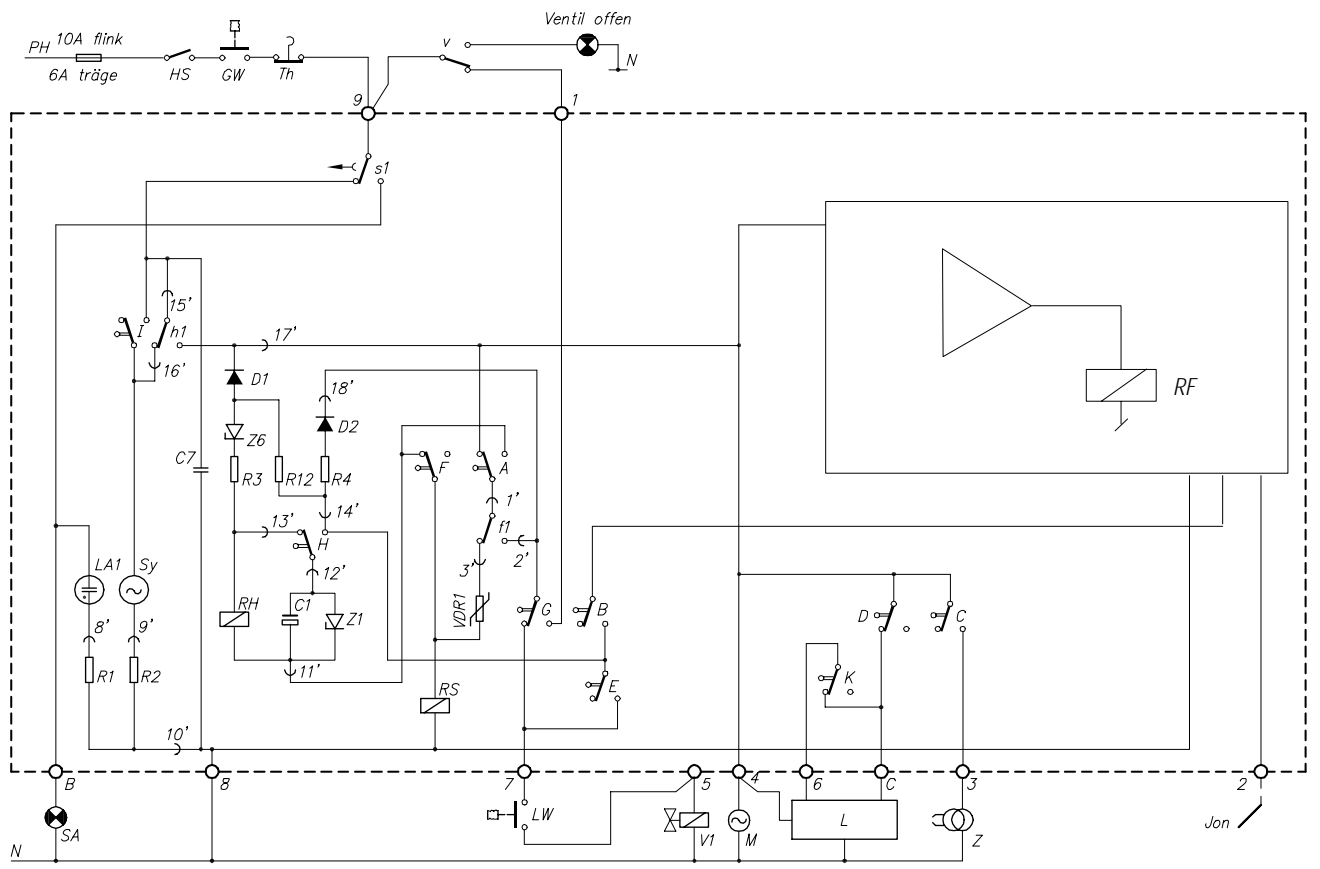

MMI 812

### MMI WITH BASE

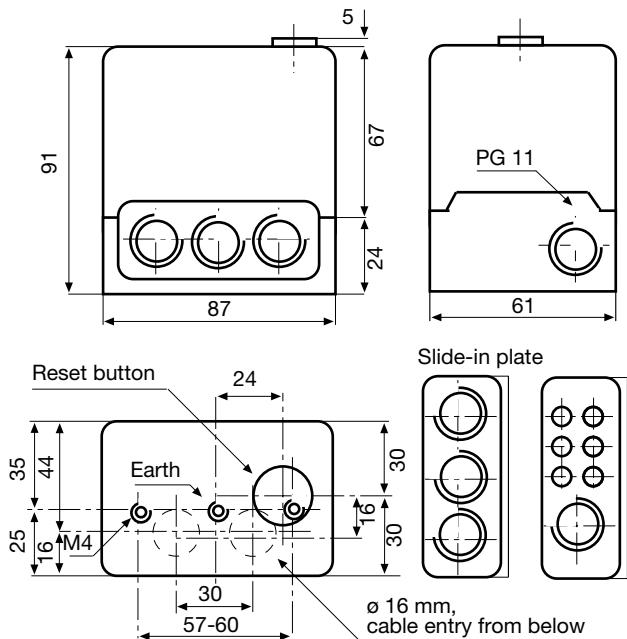

### MEASUREMENT OF THE FLAME SIGNAL

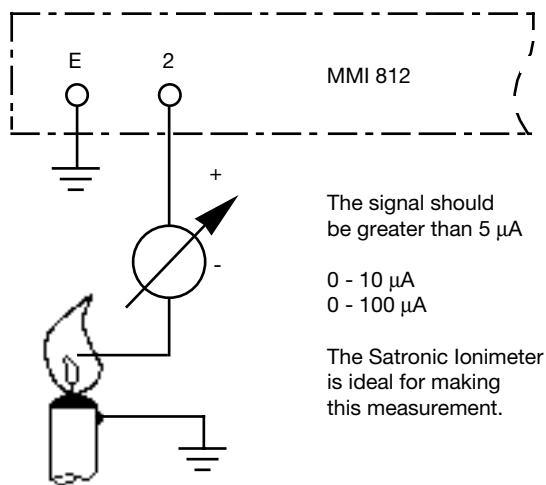

### IRD 1020

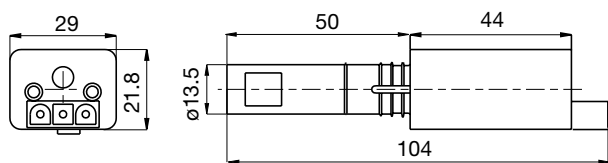

### HOLDER M93

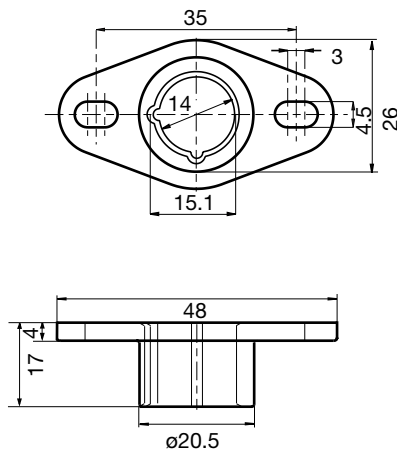

### ORDERING INFORMATION

ITEM	DESIGNATION	ITEM NO.
Control unit	Type MMI 812.1 mod. 23	06223
or	Type MMI 812 mod. 33	06205
Base for MMI 811	Base 710 TTG-FN	70102
Slide-in plate	PG-plate	70502
optionally	Cable clamping plate	70501
Flame detector	IRD 1020 end-on viewing	16522
Flame detector	IRD 1020 side-on left	16523
Flame detector	IRD 1020 side-on right	16521
IRD mounting flange	IRD Holder M93	59093
Flame detector cable	3-wire, 0.6 m	7236001

The above ordering information refers to the standard version. Special versions are also included in our product range.

Specifications subject to change without notice.

## MMI 812

**satronic**  
A Honeywell Company

Satronic AG  
Brüelstrasse 7  
Postfach 324  
CH-8157 Dielsdorf

## Gas burner automatic safety control

**For 2-stage forced draught gas burners  
 Designated for an air damper control**

**Possible flame detectors:**

- Ionization probe
- Infrared flicker detector

### INTRODUCTION

The gas burner automatic safety control MMI 813.1 controls and monitors blown gas- and combined burners of any nominal thermal load (tested and certified according to EN 298).

Together with an air damper motor, a 2-stage burner with 2 fuel valves, a 2-stage operation with 1 fuel valve or a modulating system are possible.

### CONSTRUCTIONAL FEATURES

The automatic control is housed in a non-inflammable, transparent, plug-in type plastic case and contains:

- Synchronous motor with speed reducer gears as the drive for the switching cam
- Switching cam with informative programme display in colour
- 12 times cam drive for controlling the programme sequence
- Plug-in type circuit boards with the electronic components

The following important indicating - and operating elements are located on the front panel of the automatic control:

- Illuminated pushbutton for indication of malfunctions and reset
- Programme display in colour
- Screw for central mounting



### TECHNICAL DATA

Operating voltage	220 / 240 V (-15... +10%)
Differing frequency	50 Hz (50 - 60 Hz) results in a proportional deviation of the time.
Rating fuse	max. 10 A rapid, 6 A slow
Power consumption	10 VA
Max. current per output	
term. 3	2A, cos φ 0.2
term. 4, B	2A, cos φ 0.4
term. 5, 6, C	1A, cos φ 0.4
Total load	5A, cos φ 0.4
Amplifier sensitivity	1 μA
Minimum required	
ionization current	5 μA
Flame detector cable	max. 20 m cable length
Air pressure monitor	1 working contact 4 A, 220 V
Waiting time for malfunction remedy	none
Running time	
air damper for 90°	max. 15 sec.
Flame detector	
- Ionization probe	
- Infrared flicker detector	IRD 1020
Weight, incl. base	350 g
Mounting position	any
Insulation standard	IP 44
Admissible ambient temperature for controller and flame detector	-20° C... +60° C
Classification acc. EN 298	BTLXN

Automatic Control	MMI 813.1
Model	23
Waiting time at start approx. tw	9
Maximum reaction time of air pressure monitor t <sub>lw</sub>	10
Pre-purge time tv <sub>1</sub>	34
Air damper open signal during pre-purge t <sub>lk</sub>	36.5
Pre-ignition time tv <sub>z</sub>	3
Ignition time, overall tz	6
Ignition safety time ts	3
Delay time terminal 6 tv <sub>2</sub>	6

For external resetting, the remote reset device FR 870 (art. No. 70700) can be utilized. (Refer to documentation 750).

## APPLICATION TECHNOLOGY FEATURES

### 1. Flame Monitoring

The flame monitoring can be effected with the following flame detectors:

- With ionization electrodes in power grids with earthed neutral conductor, utilizable with gas burners (interference effects of the ignition spark cannot influence the formation of the flame signal).
- With infrared flicker detector type IRD 1020 for all types of burners.

### 2. Burner Control

- The burner controls features a low-voltage protection. If the supply voltage drops below 160 V during operation, the burner switches-off. When the supply voltage raises above 180 V, the burner performs a restart independently.
- The automatic burner controls MMI only operate, when a load is connected to terminal 5. If the fuel valve is interrupted by an external contact during the pre-purging phase, a resistance of max. 22 kW, 4 Watt has to be applied between the terminals 5 and 8.
- Functional test of the air pressure monitor before the startup and monitoring of the air pressure during the pre-purging time, as well as in the operating condition of the burner. For normal applications a working contact with a power rating of 4 A / 220 V is sufficient.
- In the case of the automatic control MMI 813.1, contacts can be installed between the terminals 1 and 9 (e.g., valve limit position contacts). These are checked for their correct closing position when the unit is started up. The connection 1-9 has to be closed during the starting phase of the automatic control.

### 3. Safety

With respect to design and programme sequence, the gas burner automatic safety controls of the MMI type range comply with the currently applicable European standards and regulations.

### 4. Mounting and Electrical Installation

Wiring base:

- 3 earth terminals with additional terminal for burner earthing
- 3 neutral terminals with internal permanent connection to neutral terminal 8
- 2 independent spare terminals (S1 and S2)
- extra terminals A, B and C are standard
- 2 slide-in plates and 2 easy knock out holes (PG11 thread) plus 2 knock out holes in the base bottom facilitate the base wiring

General:

- Mounting position as required, insulation standard IP 44 (splash-proof). The automatic control and sensor should, however, not be exposed to excessive vibration.
- During mounting and installation, the applicable regulations for installation have to be observed.

## COMMISSIONING AND SERVICE/MAINTENANCE

### 1. Important Remarks

- Before commissioning, the wiring has to be accurately checked. Faulty wiring can damage the unit and endanger the safety of the installation.
- The mains fuse has to be selected so that the limit values indicated under "Technical Specifications" are under no circumstances exceeded. Non-compliance with this regulation can have very serious consequences for the control unit and for the installation in the case of a short-circuit.
- For safety reasons, at least one control shut-down per 24 hours must be assured.
- The control unit must be plugged-in or -out only when the mains supply has been disconnected.
- Automatic burner safety controls are safety devices and must not be opened.

### 2. Functional Check

During commissioning and after an overhaul of the burner, the following checks have to be carried out:

- a) Starting test with closed manual valve and bridged gas monitor contact:
  - The device must go into a fault condition after the safety period has elapsed.
- b) Close the manual valve in operating position with the gas monitor contact bridged.
  - The device must go into a fault condition after a flame failure.
- c) Air pressure monitor contact interrupted:
  - Device goes into a fault condition.
- d) Bridge air pressure monitor contact before starting:
  - Device must not start.

### 3. Trouble Shooting

Burner does not go into operation, programme indication remains:

- Electrical connection defective
- Thermostat or gas monitor "OFF"

Burner does not go into operation, programme indication rotates continuously:

- Air pressure monitor defective, respectively, not in starting position. (Working contact must be open).
- Connection term. 1 - term. 9 interrupted
- mains voltage < 180V

The automatic control switches to fault condition shortly after the start of the pre-purge time (line within the blue zone):

- Air pressure monitor contact does not close
- No load on terminal 5
- Flame signal

Automatic control switches to fault condition during the pre-purge (blue zone):

- Air pressure monitor contact open
- Flame signal (stray light)

Automatic control switches to fault condition during the safety time (yellow zone):

- No flame formation (ignition missing, valve does not open, etc.)
- No flame signal or too weak flame signal (flame does not adhere, poor insulation of the flame detector, burner not properly connected to the earth conductor).

Automatic control switches to fault condition during the operating position (red, resp. green zone):

- Flame lift-off
- Air pressure monitor contact opens
- Flame signal too weak.

**SCHEMATIC CONNECTION DIAGRAM AND PROCESS DIAGRAM MMI 813.1 WITH AIR DAMPER CONTROL**

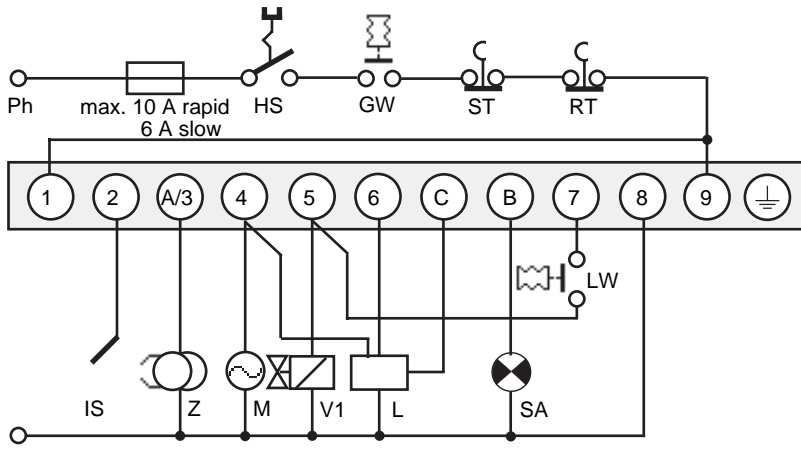

**WITHOUT AIR DAMPER CONTROL**

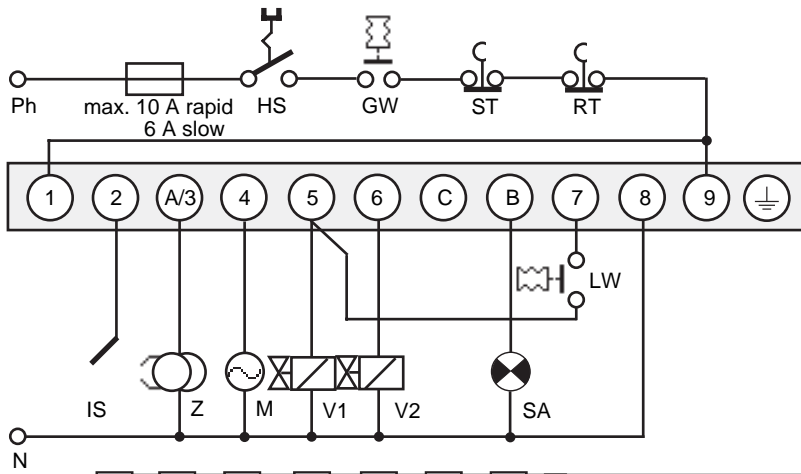

- HS Main switch
- GW Gas pressure switch
- ST Limit thermostat
- RT Control thermostat
- IS Ionization probe
- Z Ignition
- M Burner motor
- V1 Solenoid valve 1st stage
- V2 Solenoid valve 2nd stage
- L Air damper control unit
- LW Air pressure monitor
- SA External fault indication
- tw Waiting time at start-up
- tlw max. reaction time of air pressure monitor
- tv1 Pre-purge period
- tlk Air damper open signal during pre-purge
- tvz Pre-ignition period
- tz Overall ignition period
- ts Safety period
- tv2 Time delay terminal 6

**IRD CONNECTION**

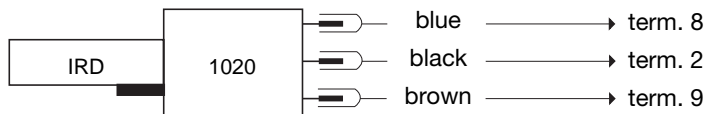

**SCHEMATIC DIAGRAM MMI 813.1**

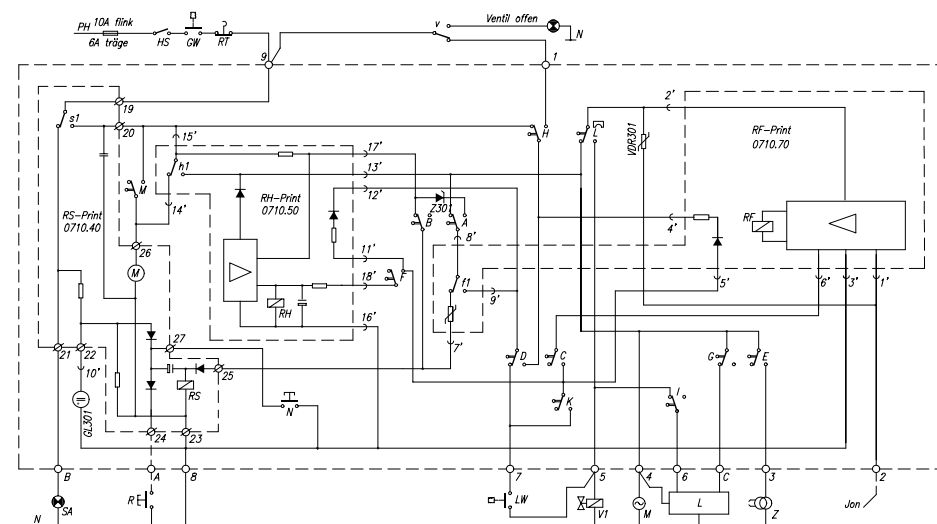



# Gas burner automatic safety control

**For power gas burners**  
**Terminals for air damper motor**  
**Built-in remote reset for lock-outs**

**Possible flame detectors:**

- Ionization probe
- Infrared flicker detector

## INTRODUCTION

The gas burner automatic safety control MMI 962.1 controls and monitors blown gas- and combined burners of any nominal thermal load (tested and certified according to EN 298).

If an air damper unit is connected, a 2-stage operation with two fuel valves or a modulating operation with one fuel valve is possible.

Various types and model designations differentiate the automatic safety controls with respect to the programme times, as well as with regard to differing national standards. The control box type MMI 962.1 Mod. 23 can be used instead of the types MMI 812 Mod. 23 or MMI 812.1 Mod. 23.

## CONSTRUCTIONAL FEATURES

The automatic control is housed in a non-inflammable, transparent, plug-in type plastic case and contains:

- Synchronous motor with speed reducer gears as the drive for the switching cam
- Switching cam with informative programme display in colour
- 12 times cam assembly for controlling the programme sequence
- Plug-in type circuit boards with the electronic components

The following important indicating - and operating elements are located on the front panel of the automatic control:

- Illuminated pushbutton for indication of malfunctions and reset
- Programme display in colour
- Screw for central mounting



## TECHNICAL DATA

Operating voltage	220 / 240 V (-15... +10%)
	50 Hz
Differing frequency	Results in a proportional deviation of the time max. 10 A rapid, 6 A slow
Rating fuse	
Power consumption	10 VA
Max. load per output:	
- term. 3	2A, cos φ 0.2
- term. 4, B	2A, cos φ 0.4
- term. 5, 6, C	1A, cos φ 0.4
total load	5A, cos φ 0.4
Amplifier sensitivity	1 μA
Minimum required ionization current	5 μA
Flame detector cable	max. 20 m cable length
Air pressure monitor	working contact 4 A, 230 V
Waiting time for malfunction remedy	None
Flame detector	
- Ionization probe	
- Infrared flicker detector	IRD 1020
Weight, incl. base	350 g
Mounting position	any
Insulation standard	IP 44
Admissible ambient temperature for controller and flame detector	-20° C... +60° C
Classified acc. to EN 298	BTLXN

program timings (sec.)	MMI 962.1
Model	23
Waiting time at start-up tw	8
Max. reaction time for air proving switch tlw	15
Pre-purge time tv1	30
LK open signal tlk	38
Pre-ignition time tvz	3
Total ignition time tz	6.6
Safety time ts	3
Time delay term.6 / term.C tv2	8

## APPLICATION TECHNOLOGY FEATURES

### 1. Flame Monitoring

The flame monitoring can be effected with the following flame detectors:

- With ionization electrodes in power grids with earthed neutral conductor, utilizable with gas burners (interference effects of the ignition spark cannot influence the formation of the flame signal).
- With infrared flicker detector type IRD 1020 for all types of burners. (siehe Dok. 746)

### 2. Burner Control

- The burner controls MMI 962.1 features a low-voltage protection. If the supply voltage drops below 160 V during operation, the burner switches-off. When the supply voltage raises above 180 V, the burner performs a restart independently.
- The automatic burner controls MMI only operates when a load is connected to terminal 5. If the fuel valve is interrupted by an external contact during the pre-purging phase, a resistance of max. 22 kW, 4 Watt has to be applied between the terminals 5 and 8.
- Functional test of the air pressure monitor before the startup and monitoring of the air pressure during the pre-purging time, as well as in the operating condition of the burner. For normal applications a working contact with a power rating of 4 A / 230 V is sufficient.
- In the case of the automatic control MMI 962.1, contacts can be installed between the terminals 1 and 9 (e.g., valve limit position contacts). These are checked for their correct closing position when the unit is started up. The connection 1-9 has to be closed during the starting phase of the auto-matic control.
- No fuel valve must be connected to terminal 6.

### 3. Safety

With respect to design and programme sequence, the gas burner automatic safety controls of the MMI 962 type range comply with the currently applicable European standards and regulations.

### 4. Mounting and Electrical Installation

Wiring base:

- 3 earth terminals with additional terminal for burner earthing
- 3 neutral terminals with internal permanent connection to neutral terminal 8
- 2 independant spare terminals (S1 and S2)
- extra terminals A, B and C are standard
- 2 slide-in plates and 2 easy knock out holes (PG11 thread) plus 2 knock out holes in the base bottom facilitate the base wiring

General:

- Mounting position as required, insulation standard IP 44 (splash-proof). The automatic control and sensor should, however, not be exposed to excessive vibration.
- During mounting and installation, the applicable regulations for installation have to be observed.

Remote reset for lock-outs:

- For the external reset, a temporary switch (push-button switch) has to be wired between terminals A and Mp.
- The terminal A can be broke-off if not used.

## COMMISSIONING AND SERVICE/MAINTENANCE

### 1. Important Remarks

- Before commissioning, the wiring has to be accurately checked. Faulty wiring can damage the unit and endanger the safety of the installation.
- The mains fuse has to be selected so that the limit values indicated under "Technical Specifications" are under no circumstances exceeded. Non-compliance with this regulation can have very serious consequences for the control unit and for the installation in the case of a short-circuit.
- For safety reasons, at least one control shut-down per 24 hours must be assured.
- The control unit must be plugged-in or -out only when the mains supply has been disconnected.
- Automatic burner safety controls are safety devices and must not be opened.

### 2. Functional Check

During commissioning and after an overhaul of the burner, the following checks have to be carried out:

- a) Starting test with closed manual valve and bridged gas monitor contact:
  - The device must go into a fault condition after the safety period has elapsed.
- b) Close the manual valve in operating position with the gas monitor contact bridged.
  - The device must go into a fault condition after a flame failure.
- c) Air pressure monitor contact interrupted:
  - Device goes into a fault condition.
- d) Bridge air pressure monitor contact before starting:
  - Device must not start.

### 3. Trouble Shooting

Burner does not go into operation, programme indication remains:

- Electrical connection defective.
- Thermostat or gas monitor "OFF".

Burner does not go into operation, programme indication rotates continuously:

- Air pressure monitor defective, respectively, not in starting position. (Working contact must be open).
- Connection term. 1 - term. 9 interrupted
- mains voltage < 180V

The automatic control switches to fault condition shortly after the start of the pre-purge time (line within the blue zone):

- Air pressure monitor contact does not close.
- No load on terminal 5.
- Flame signal.

Automatic control switches to fault condition during the pre-purging (blue zone):

- Air pressure monitor contact open
- Flame signal (stray light)

Automatic control switches to fault condition during the safety time (yellow zone):

- No flame formation (ignition missing, valve does not open, etc.)
- No flame signal or too weak flame signal (flame does not adhere, poor insulation of the flame detector, burner not properly connected to the earth conductor).

Automatic control switches to fault condition during the operating position (red, resp. green zone):

- Flame lift-off
- Air pressure monitor contact opens
- Flame signal too weak.

**SCHEMATIC CONNECTION DIAGRAM AND PROCESS DIAGRAM MMI 962.1**

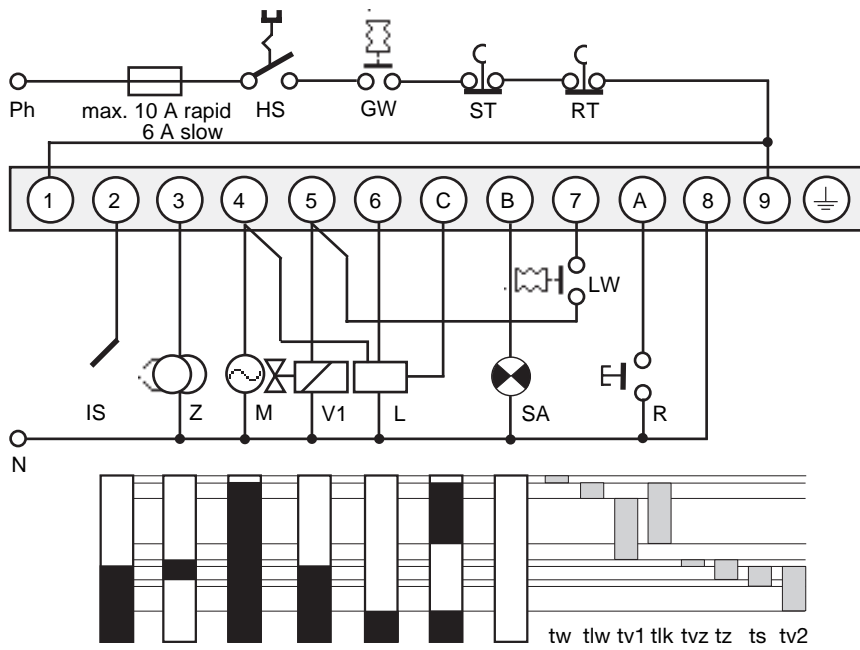

- HS Mains switch
- GW Gas pressure switch
- ST Limit thermostat
- RT Control thermostat
- IS Ionization probe
- Z Ignition
- M Burner motor
- V1 Solenoid valve 1st stage
- L Air damper unit
- LW Air pressure monitor
- SA External fault indication
- R Remote reset temporary switch
  
- tw Waiting time at start-up
- tlw Max. reaction time for air proving switch
- tv1 Pre-purge time
- tlk LK open signal
- tvz Pre-ignition time
- tz Total ignition time
- ts Safety time
- tv2 Time delay term. 6 / term. C

**IRD CONNECTION**

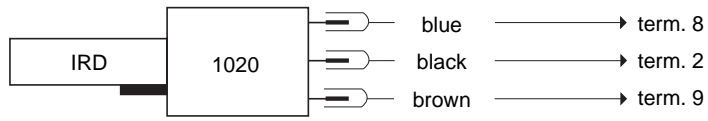

**SCHEMATIC DIAGRAM MMI 962.1**

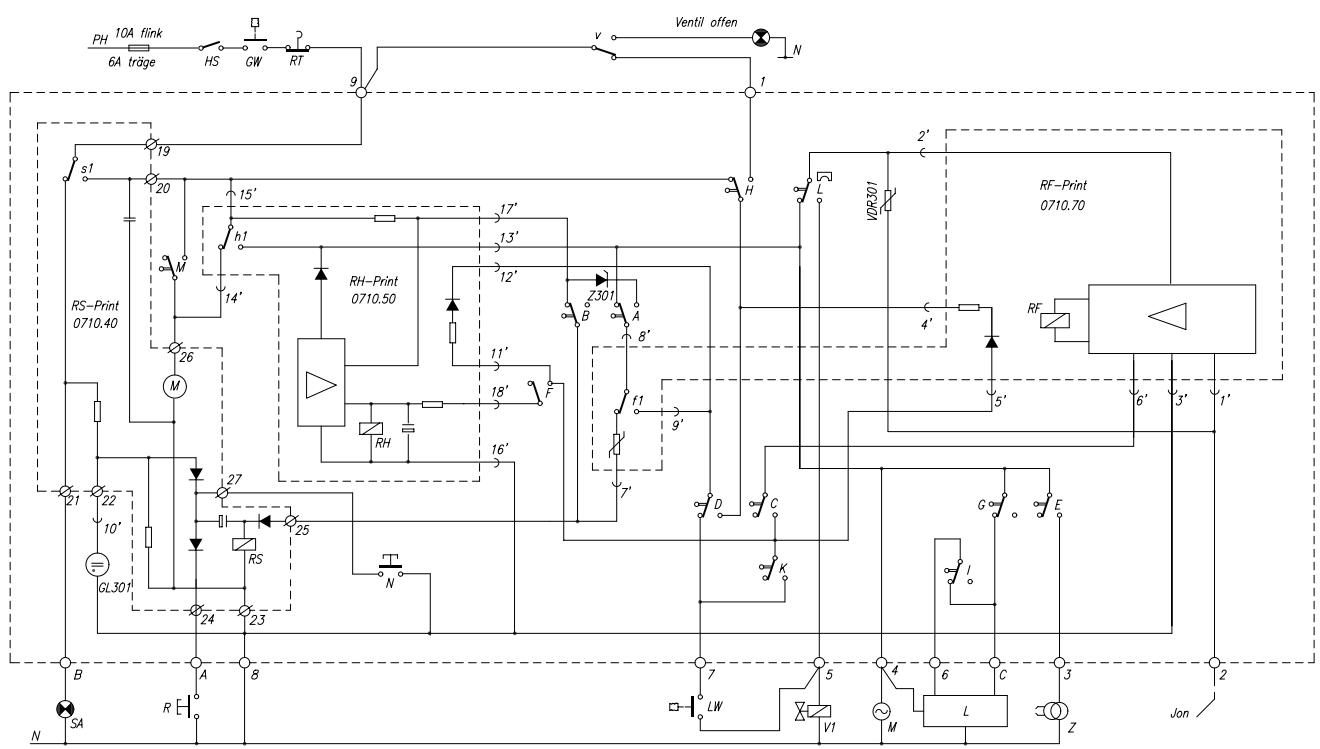

MMI 962.1

### MMI WITH BASE

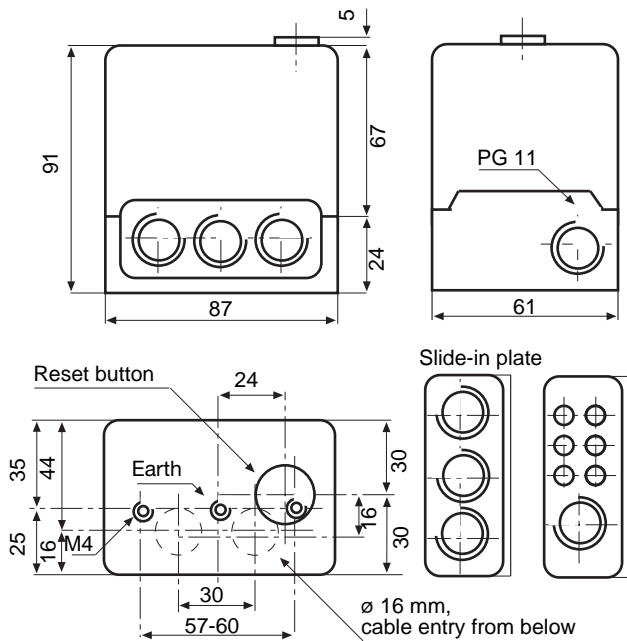

### MEASUREMENT OF THE FLAME SIGNAL

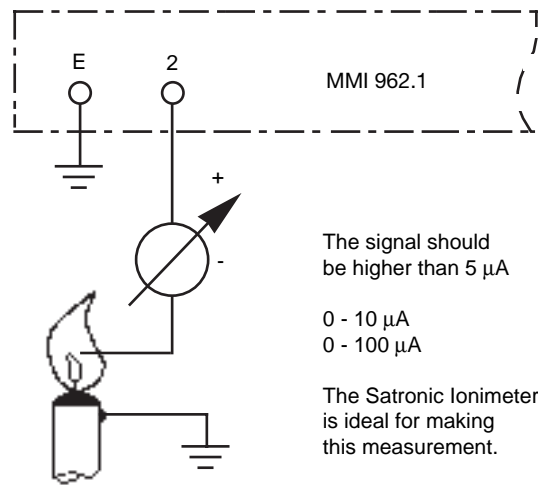

### IRD 1020

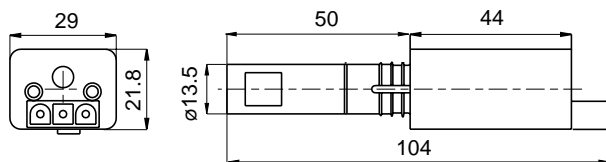

### HOLDER M 93

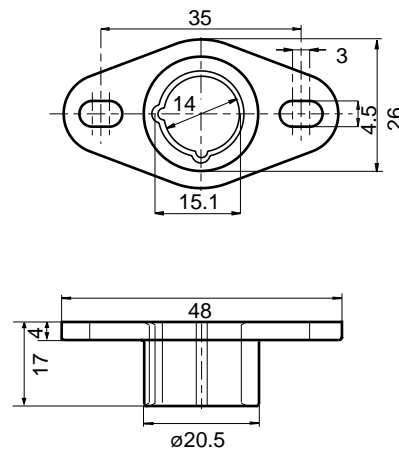

### ORDERING INFORMATION

ITEM	DESIGNATION	ITEM NO.
Control unit	Type MMI 962.1 mod. 23	06256
Socket	Wiring base S 98	75310
Multewire base	Wiring base MW 880 ABC	74001
Slide-in plate	PG-plate	70502
optionally	Cable clamping plate	70501
Flame detector	IRD 1020 end-on viewing	16522
Flame detector	IRD 1020 side-on left	16523
Flame detector	IRD 1020 side-on right	16521
IRD mounting flange	Mounting flange M 93 for IRD 1020	59093
Flame detector cable	3-wire, 0.6 m	7236001

The above ordering information refers to the standard version.  
Special versions are also included in our product range.

Specifications subject to change without notice.

## MMI 962.1

**satronic**  
A Honeywell Company

Satronic AG  
Brüelstrasse 7  
Postfach 324  
CH-8157 Dielsdorf

## Burner Control Box

**For 2-stage forced draught and combi oil/gas burners**

**Suitable flame detectors:**

- Ionisation probe
- UV sensor
- Infra-red flicker detector

### INTRODUCTION

The MMG burner control box is capable of controlling and monitoring forced draught and combi oil/gas burners of any nominal rating (tested and approved as per EN 298). The MMG 810.1 model 33 control boxes are also suitable for use in stationary warm air generators (Direct air heaters according to DIN 4794).

Different type and model designations identify the control boxes according to varying national standards, and to some extent, according to programme times.

### TYPES AVAILABLE

MMG 810.1	Mod. 33	Art. Nr. 0640220
	Mod. 43	Art. Nr. 0642520
	Mod. 45	Art. Nr. 0642620
MMG 811.1	Mod. 33	Art. Nr. 0640520
	Mod. 63	Art. Nr. 0640420

### CONSTRUCTIONAL FEATURES

The control box is enclosed in a protective, flame resistant, transparent, plug-in type plastic housing, and includes:

- Synchronous motor with reduction gearing driving cam switch
- Cam switch with informative, coloured programme indicator
- 12-way cam switch assembly controlling the programme sequence
- Electronic components on plug-in printed circuit

The following important indicators and operating controls are situated on the front of the control box:

- Reset button incorporating signal lamp for malfunction (lockout)
- Coloured programme indicator
- Central screw fastening



### TECHNICAL DATA

Supply voltage	220 / 240 V (-15... +10%)
AC frequency variations	50 Hz (50 - 60 Hz) result in proportional timing deviations
Fuse rating	max. 10 A rapid, 6 A slow
Power consumption	10 VA
Max. current per output term. 3	2A, cos φ 0.2
term. 4, B	2A, cos φ 0.4
term. 5, 6, C	1A, cos φ 0.4
Total load	5A, cos φ 0.4
Amplifier sensitivity	1 μA
Min. current from UV tube or ionisation probe	5 μA
Flame detector cable	max. 20 m cable length
Air proving switch	1 terminal 4 A, 230 V
Reset delay	none
Flame detector	
- Ionisation probe	
- Infra-red flicker detector	IRD 1020
- UV tube type	UVZ 780 red markings installed radially or axially
Infra red flare detector	IRD 1020
Weight incl. base	350 g
Mounting attitude	any
Insulation standard	IP 44
Permissible ambient temp.	-20° C... +60° C
Classified acc. to EN 298	BTLXN

program timings (sec.)	MMG 810.1			811.1	
Model	33	43	45	33	63
Waiting time at start-up					
tw	9	9	9	9	6
Max. reaction time for air proving switch					
tlw	6	6	6	6	5
Pre-purge time					
tv1	24	40	40	24	55
Pre-ignition time					
tvz	3	3	3	3	3
T. ignition time					
tz	6	6	8	6	5.5
Safety time					
ts	3	3	5	3	3
Time delay term.6 / term.C					
tv2	10	10	10	10	6

For external resetting, the remote reset device FR 870 (art. No. 70700) can be utilized. (Refer to doc. 750).

## TECHNICAL FEATURES

### 1. Flame detection

The following types of flame detector can be employed:

- Ionisation electrode, where the mains supply provides a neutral earth connection. Suitable for gas burners (signal current from flame cannot be influenced by interference from ignition spark).
- UV sensor type UVZ 780 red, suitable for gas and combi burners.
- Infra-red flicker detector type IRD 1020 for all types of burner.

### 2. Burner Control

- The burner controls features a low-voltage protection. If the supply voltage drops below 160 V during operation, the burner switches-off. When the supply voltage raises above 180 V, the burner performs a restart independently.
- The MMG control boxes only operate when a load is connected to terminal 5. If the fuel valve is isolated during the pre-purge by way of an external switch contact, a resistor with a value of max. 22 k $\Omega$ /4 watts, must be connected between terminals 5 and 8.
- Functional check of the air proving switch before the start, and monitoring of the air pressure during pre-purge as well as during normal operation. In normal use, switch contacts with a rating of 4 A / 220 V are sufficient.
- On the MMG 810.1, switch contacts (e.g. valve end contact) can be wired between terminals 1 and 9. These contacts are checked for proper closure during the burner start phase. The connection between terminals 1 and 9 must be complete during the start phase.
- The MMG 810.1 control box monitors the ignition spark if the UVZ 780 (red) is used for flame detection, and terminals C and 9 are wired together.

### 3. Safety

The design/construction and programme sequence of the control boxes in the MMG series conform to the present applicable European standards and regulations.

### 4. Installation

At the base:

- 3 earth terminals, with an additional tag for the burner earth.
- 3 neutral terminals, with a fixed internal through connection to the neutral input, terminal 8.
- 2 separate slide-in plates and 2 fixed, threaded knock-outs (PG 11 thread) as well as 2 knock-outs underneath, facilitate wiring of the base.

General:

- Can be mounted in any position, insulated as per IP 44 standard (unaffected by water spray). The control box and detector probes should however not be subjected to excessive vibration.
- The applicable installation regulations must be observed during installation.

## COMMISSIONING AND MAINTENANCE

### 1. Important

- The wiring must be checked exactly when commissioning the installation. Incorrect wiring could damage the control box, putting the safety of the burner system at risk.
- The chosen fuse rating must not, on any account, be higher than the value given in the technical data. Failure to observe this instruction could, in the case of a short circuit, have serious consequences for the control box or burner system.
- For safety reasons, it must be ensured that the control box performs at least one normal shut-down during every 24 hour period.
- Switch off or disconnect the power before plugging in or unplugging the unit.
- Control boxes are safety devices and should not be interfered with.

### 2. Functional Check

During commissioning and after an overhaul of the burner, the following checks have to be carried out:

- a) Starting test with closed manual valve and bridged gas monitor contact:
  - The device must go into a fault condition after the safety period has elapsed.
- b) Close the manual valve in operating position with the gas monitor contact bridged.
  - The device must go into a fault condition after a flame failure.
- c) Air pressure monitor contact interrupted:
  - Device goes into a fault condition.
- d) Bridge air pressure monitor contact before starting:
  - Device must not start.

### 3. Trouble Shooting

Burner does not go into operation, programme indication remains:

- Electrical connection defective.
- Thermostat or gas monitor "OFF".

Burner does not go into operation, programme indication rotates continuously:

- Air pressure monitor defective, respectively, not in starting position. (Working contact must be open).
- Connection term. 1 - term. 9 interrupted
- mains voltage < 180V

The automatic control switches to fault condition shortly after the start of the pre-purge time (line within the blue zone):

- Air pressure monitor contact does not close.
- No load on terminal 5.
- Flame signal.

Automatic control switches to fault condition during the pre-purging (blue zone):

- No flame formation (ignition missing, valve does not open, etc.)
- No flame signal or too weak flame signal (flame does not adhere, poor insulation of the flame detector, burner not properly connected to the earth conductor).

Automatic control switches to fault condition during the operating position (red, resp. green zone):

- Flame lift-off
- Air pressure monitor contact opens
- Flame signal too weak.

**SCHEMATIC CONNECTION DIAGRAM AND PROCESS DIAGRAM MMG 810.1**

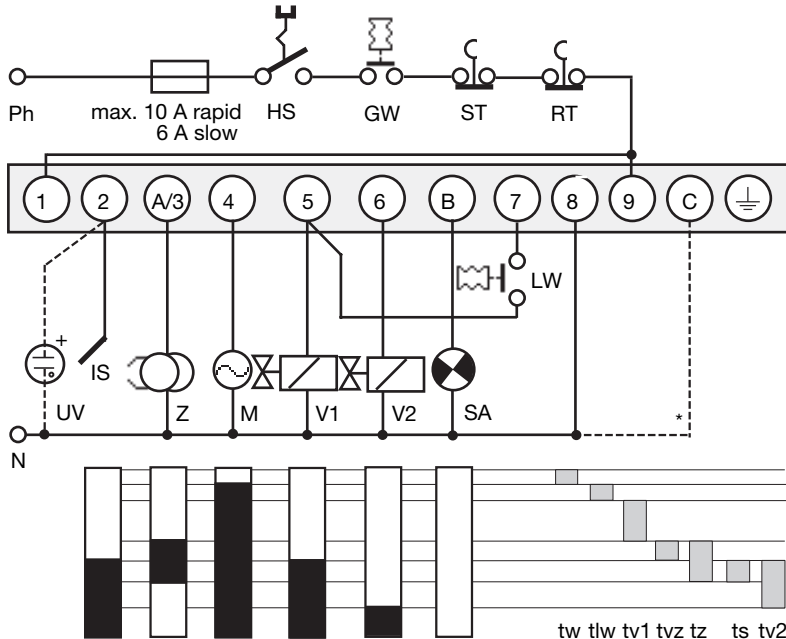

\* for ign. spark detection only

- HS Mains switch
- GW Gas pressure switch
- ST Limit thermostat
- RT Control thermostat
- IS Ionisation probe
- UV UV sensor
- Z Ignition
- M Burner motor
- V1 Solenoid valve, 1st-stage
- V2 Solenoid valve, 2nd-stage
- LW Air pressure monitor
- SA External lock-out signal for spark detection only
- SV Safety valve

- tw Waiting time at start-up
- tlw Max. reaction time for air proving switch
- tv1 Pre-purge time
- tvz Pre-ignition time
- tz Total ignition time
- ts Safety time
- tv2 Time delay term.6 / term. C

**SCHEMATIC CONNECTION DIAGRAM AND PROCESS DIAGRAM MMG 811.1**

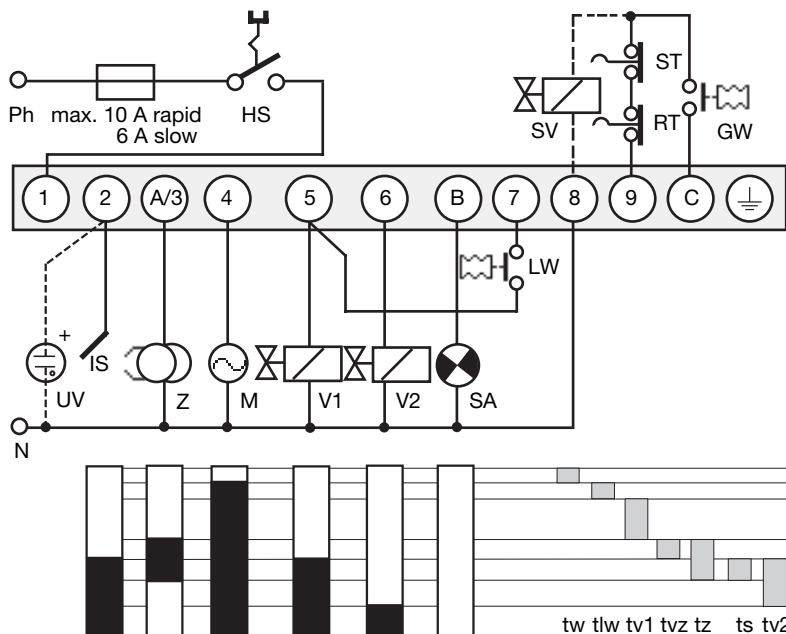

**IRD CONNECTION**

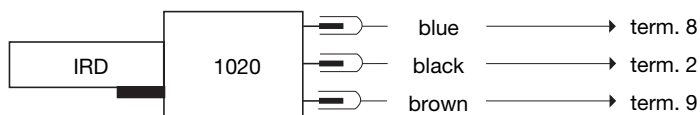

**SCHEMATIC DIAGRAMM MMG 810.1**

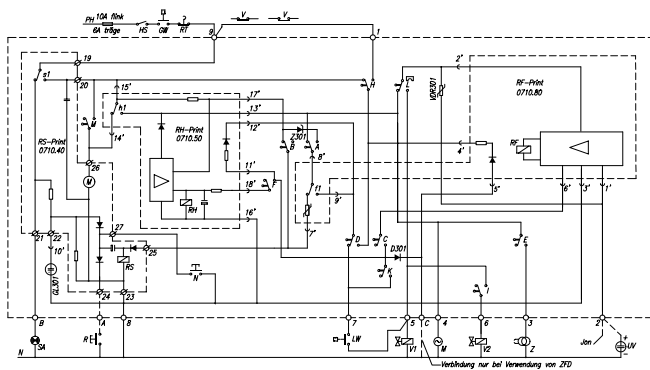

**SCHEMATIC DIAGRAMM MMG 811.1**

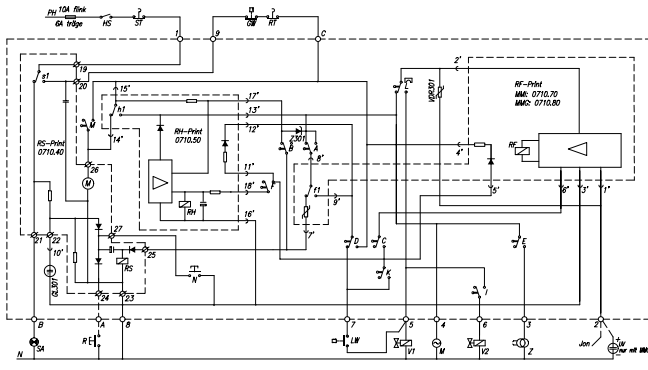

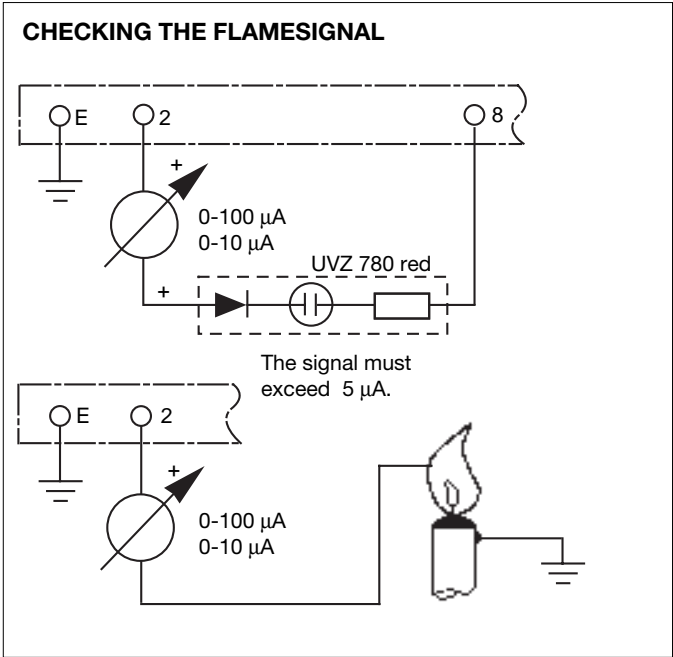
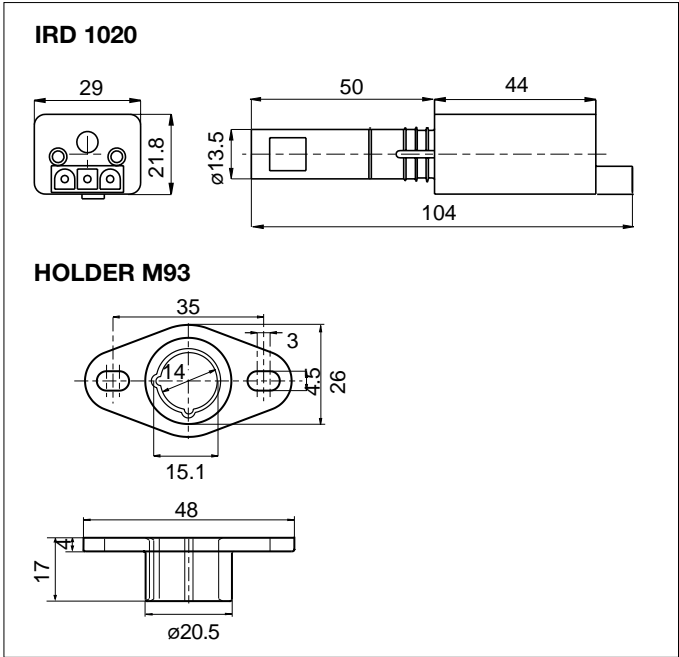
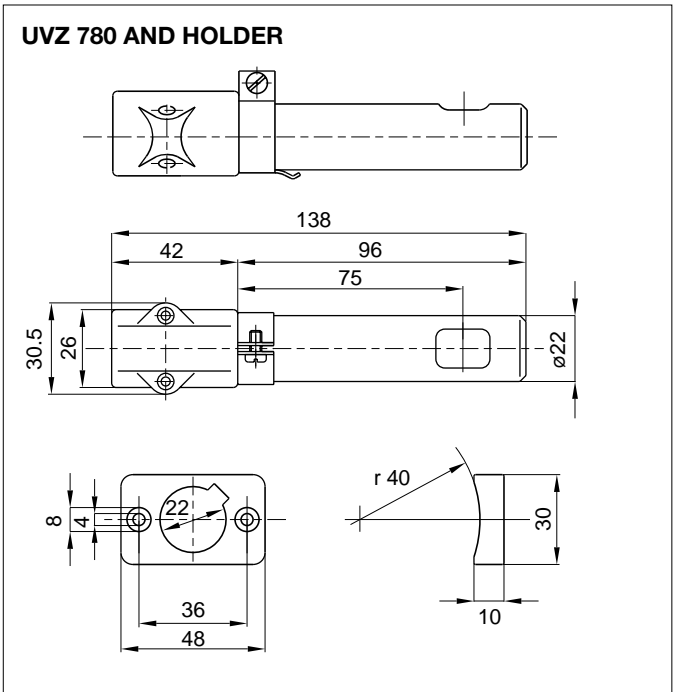
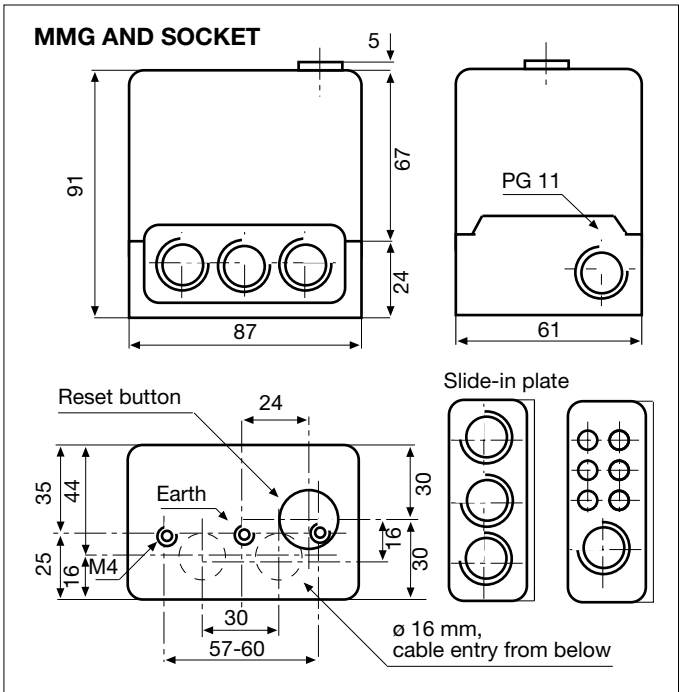

ITEM	DESIGNATION	ITEM NO.
Control box	Type MMG 810.1 mod. 33	0640220
or	Type MMG 811.1 mod. 33	0640520
Socket for MMG 810.1	Socket 701 TTG-EN	70101
Socket for MMG 811.1	Socket 701 TTG-FN	70102
Slide-in plate	Cable terminal plate	70502
or	PG-plate	70501
Flame detector	IRD 1020 end-on viewing	16522
Flame detector	IRD 1020 side-on left	16523
Flame detector	IRD 1020 side-on right	16521
Flame detector	UVZ 780 red	18813
IRD mounting flange	IRD Holder M93	59093
UVZ mounting flange	UVZ Holder	18807
Flame detector cable	3-wire, 0.6 m	7236001

The above ordering information refers to the standard version.  
Special versions are also included in our product range.

Specifications subject to change without notice.

**MMG810.1/811.1**



Satronic AG  
Brüelstrasse 7  
Postfach 324  
CH-8157 Dielsdorf

## Burner Control Box

**For high performance forced draught and dual fuel burners in intermittent operation (single or two stage versions).**

**Suitable flame detectors:**

- Ionisation probe
- UV sensor
- Infra-red flicker detector

### INTRODUCTION

The TMG 740-3 burner control box is capable of controlling and monitoring medium to high performance forced draught and dual fuel oil/gas burners in single or two stage versions. It can be used, as preferred, for multi-stage or modulating operation with burners of any nominal rating as well as in direct air heaters (as per DIN 4794).

Different model designations identify the control boxes according to programme times for varying national standards, or for special applications e.g. high-speed steam generators. A special version is available for operation with ignition spark monitoring in conformance with French national regulations.

The TMG 740-3 is fully interchangeable with the earlier versions -1 and -2.

### CONSTRUCTIONAL FEATURES

The control box is enclosed in a protective, flame resistant, transparent, plug-in type plastic housing, and includes:

- Synchronous motor with gearbox driving cam switch
- Cam switch with informative, coloured programme indicator
- 16-way cam switch assembly controlling the programme sequence
- 2 DC relays and 1 remanence relay on common yoke
- Plug-in printed circuit board with mains transformer, LED display and electronic components

On the underside of the unit are robust plug terminals where the air proving switch and monitoring of the ignition spark can be programmed via two wire links which can be cut as required. The flame detector selection switch is also situated on the the underside of the unit.

The following important indicators and operating controls can be found on the front of the control box:

- Reset button incorporating signal lamp for malfunction (lockout)
- Coloured programme indicator
- Flame signal indicator with 5 LED's
- Central screw fastening



### TECHNICAL DATA

Supply voltage	220 / 240 V (-15... +10%) 50 HZ (40 - 60 Hz)
AC frequency variations	result in proportional timing deviations
Fuse rating	10 A rapid, 6 A slow
Power consumption	approx. 15 VA
Max. current per output terminal	4 A
Total	6 A
Sensitivity	
Ionisation input	1.6 µA
UV input	70 µA
Min. sensor current	
Ionisation/IR probe	5 µA = 2 LED
UV tube	250 µA = 2 LED
Air proving switch	6 A, 220 V
Reset delay	none
Flame detector cable	
Ionisation	50 m normal cable 100 m screened cable
UV tube	100 m normal cable 200 m screened cable
UV tube	UVZ 780 blue low sensitivity UVZ 780 white medium sensitivity UVZ 780 red high sensitivity
Weight incl. base	1100 g
Mounting attitude	any
Insulation standard	IP 44
Permissible ambient temp.	-20° C to +60° C incl.
Classified acc. to EN 298	BTLLXN

Model No.	32-32 sec.	63-55 sec.	43-35 sec.	13-53* sec.
Pre-purge time supervised	24	60	32	4
Pre-purge time with air damper open	30	60	40	6
Pre-ignition time fixed	3	4	4	1
Start valve safety interval	2	3	3	3
Pilot valve safety interval	3	5	3	5
Pilot valve switch on time	11	13.5	14	8
Main valve 1 safety interval	2	5	5	3
Valve 1 delay	9	10	10	6
Valve 2 delay	6	20	10	4
Post-purge	7	16	10	-

\* For high-speed steam generators. Prescribed ventilation must be verified.

## TECHNICAL FEATURES

### 1. Flame detection

The following types of flame detector can be used:

- Ionisation electrode, where the mains supply provides a neutral earth connection. Suitable for gas burners (signal current from flame cannot be influenced by interference from ignition spark).
- UV sensor type UVZ 780 red, suitable for gas, oil and dual fuel burners.
- Infra-red flicker detector type IRD 820 and 1020 for all types of burner.

The flame signal amplifier is adjusted to the the type of detector probe fitted by using the flame detector selection switch on the underside of the unit. If the IRD flicker detector is used, the selection switch must be adjusted to the "ION" position.

Flame detection is only operational when the switch position selected corresponds to the type of detector probe connected.

By optimally matching the amplifier to the detector probe, considerably longer signal transmission distances with less sensitivity to interference can be achieved.

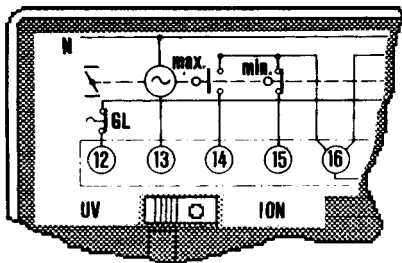

The flame signal current indicator consists of a five stage LED display which shows the signal current continuously. An indication of the strength of the flame signal current is therefore always given. Fluctuations in the monitoring sensitivity can be noticed at an early stage, and appropriate corrective action can be taken.

If the infra-red flicker detector IRD 820 or 920 is employed, the flame signal current indicator on the control box is not relevant. In this case, the IRD indicator is the decisive indication of flame signal strength.

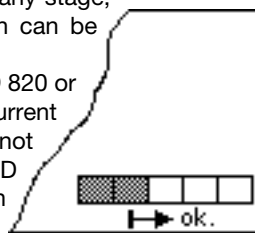

Flame signal current indicator

### 2. Burner Control

- Burners can be operated with or without post-purge. This varies according to model (see technical data) and is activated when the burner motor is connected to terminal 19.
- Air damper operation is monitored to ensure the nominal air volume during pre-purge and in the starting position before fuel is released. If confirmation of the damper positions "MIN" and "MAX" is not received, the control box start sequence is interrupted.
- The air proving switch is checked for correct operation before the start, and air pressure is monitored during pre-purge as well as during normal operation. In normal use, switch contacts with a rating of 6A/220V are sufficient. Additional switch contacts which are to be monitored can be connected between terminal 18 and the air proving switch working contact. In this case, jumper II on the underside of the control box should be cut.

- A separate connection for a pilot valve PV is provided, which is again closed at the end of the second safety interval. The heat output of the gas flow which is controlled by this valve must not exceed 120kW.
- The terminal for the start valve SV must not be used when connecting the pilot valve PV.
- Together with the start valve SV, a total of 3 power levels are available for use. The gas flow controlled by valves SV, V1 and V2 must lead to a common nozzle unit.
- To determine the heating power of the gas flow controlled by the pilot- and start valve, EN 676 has to be consulted.
- In addition to the built-in button with signal lamp, it is also possible to connect a remote lockout indicator and reset switch.
- For monitoring of the ignition spark, link 1 on the base of the control box must be cut. In this case, flame detection is carried out by a UVZ 780 ultra-violet sensor.

### 3. Safety

The design and programme sequence employed in the control boxes in the TMG 740-3 series conform to the presently applicable European standards and regulations. The following features exceed the requirements of most standards, and therefore ensure additional safety:

- After a normal shutdown, the stray light test is started immediately by the control box which directs an increased voltage to the UV sensor. The very important extinguishing function of the sensor can therefore be checked. If the fuel valve does not close correctly, or a sensor or amplifier malfunction occurs, shutdown and lockout take place after approx. 20 sec., even if the controlling thermostat is open.
- The contacts responsible for the release of fuel are checked when the programme starts, to ensure that they have not become welded together.

### 4. Mounting and Electrical Installation

At the base:

- 3 earth terminals, with an additional tag for the burner earth.
- 3 neutral terminals, with a fixed internal through connection to the neutral input, terminal 8.
- 2 separate slide-in plates and 4 fixed, threaded knockouts (PG 11 thread) as well as a wiring opening from below, to facilitate wiring of the base.
- A keyed fit ensures that the wrong control box type cannot be fitted to the base. The corresponding control box designation is shown in lettering on the base.

General:

- Can be mounted in any position, insulated as per IP 44 standard (unaffected by water spray). The control box and detector probes should not however be subjected to excessive vibration. With the UVZ 780 ultra-violet sensor, care should be taken to ensure that a good electrical contact to the burner exists via the metal flange.
- If an ionisation electrode is used, appropriate protective measures are required in order to avoid contact with the electrode while installation work is being carried out. Trouble-free operation with this type of flame detection is not possible if a voltage of over 25 volts is measured between neutral and earth. In this case, provision must be made for a separate isolating transformer.
- The maximum lengths for the detector probe cables, depending on the type of cable installed, are listed in the technical data and must be adhered to without fail. Laying the cables parallel to mains cabling over long distances should be avoided, and the use of multiple core cable is also not permitted.

### WIRING DIAGRAMS

### IRD CONNECTION

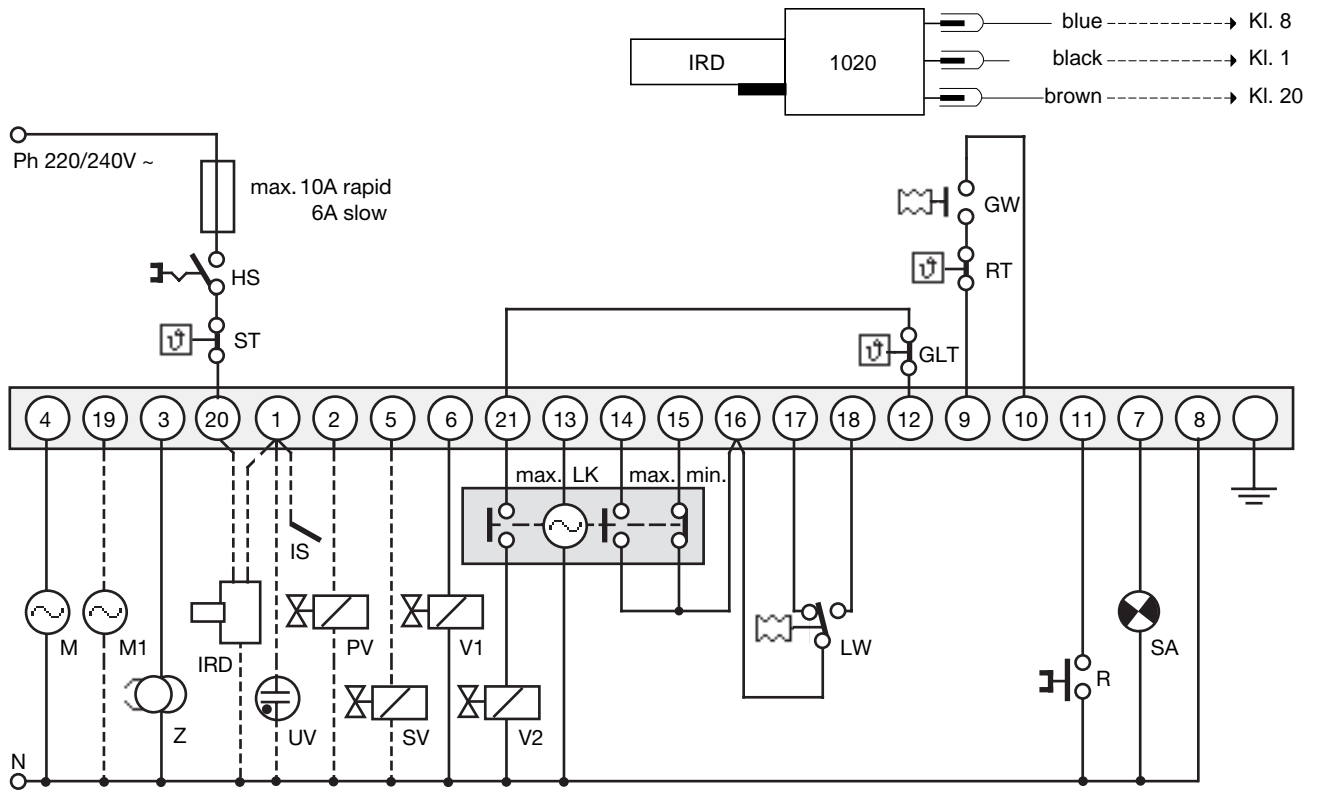

- |     |                               |    |  |
|-----|-------------------------------|----|--|
| HS  | Mains switch                  | IS | Flame ionisation probe                   |
| ST  | Limit thermostat              | PV | Pilot flame gas valve                    |
| GW  | Gas Pressure proving switch   | SV | Start flame gas valve                    |
| RT  | Control thermostat            | V1 | Main flame gas valve                     |
| GLT | High/low operation thermostat | V2 | High flame or modulation stage gas valve |
| M   | Burner motor                  | LK | Air damper motor or actuator             |
| M1  | Burner motor for post-purge   | LW | Air pressure proving switch              |
| Z   | Ignition transformer          | R  | Remote reset switch                      |
| IRD | Infra-red flicker detector    | SA | External lockout signal lamp             |
| UV  | UV-cell                       |    |  |

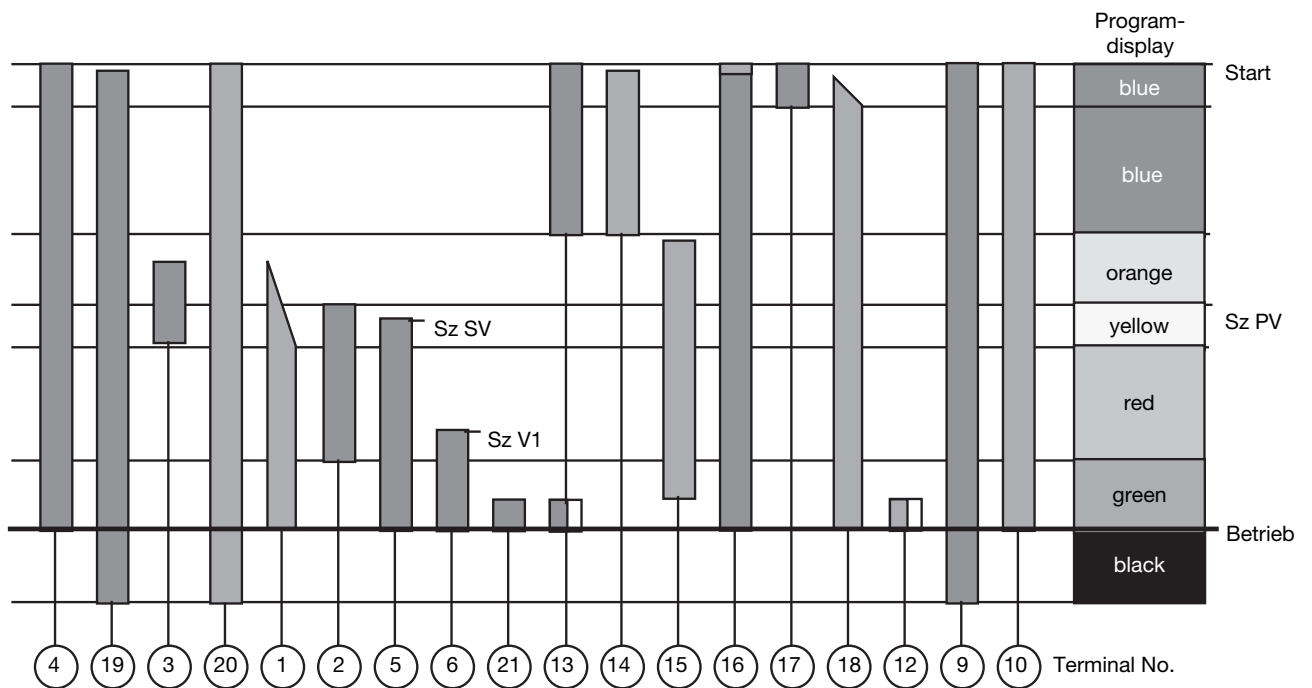

required Input
  Output

## COMMISSIONING AND MAINTENANCE

### 1. Important

The wiring must be checked exactly when commissioning the installation. Incorrect wiring could damage the control box, putting the safety of the burner system at risk. When mounting and wiring the control box, the applicable installation regulations must be observed.

- The chosen fuse rating must not, on any account, be higher than the value listed in the technical data.
- Failure to observe this instruction could, in the case of a short circuit, have serious consequences for the control box or burner system.
- For safety reasons, it must be ensured that the control box performs at least one normal shutdown during every 24 hour period.
- Switch off or disconnect the power before plugging in or unplugging the unit.
- Burner control boxes are safety devices and should not be opened.

### 2. Routine Checks

An inspection of the technical safety of the flame detection system must be carried out during commissioning of the unit as well as after servicing, or if the system has not been in operation over a long period.

For test a), the gas proving switch should be bridged.

- a) Attempt to start with the hand valve closed:
  - After the first safety interval has elapsed
  - > Lockout
- b) During normal operation, interrupt detector probe or cut off light:
  - In less than 1 sec.
  - > Lockout

### Fault finding

Fault finding is considerably simplified by making use of the coloured programme indicator. Irregularities during commissioning, normal operation or a normal shutdown pause can be localised via the programme indicator disc. If a malfunction occurs, it is useful to note the exact position of the indicator before operating the control switch or reset button.

The following list is designed to assist with fault finding.

COLOUR	WHERE	WHAT	REASON
BLUE	beginning	doesn't start	- no power, break in control circuit, air proving switch not in resting position
	line end anywhere	continuous ventilation lockout continuous ventilation lockout	- end switch "MAX" air damper doesn't operate - air proving switch doesn't switch over or is too late - end switch "ignition position", air damper doesn't operate - stray light
YELLOW	end	lockout	- flame establishment pilot or start valve impossible no flame signal current or too weak (min. 2 LED's) flame detector selector switch set incorrectly
RED	end	lockout	- no flame signal current or too weak after end of second safety interval (double fuel feed burner)
GREEN	end	lockout	- loss of flame during operation, air pressure too low
BLACK	end	lockout	- stray light due to burning on, UVZ sensor tube reached end of life and activates shutoff, defect in flame detector circuit

A test baseplate is available for checking the burner control box functions (model designation UP 7520, item no. 18601)

### BURNER 1- OR 2-STAGE

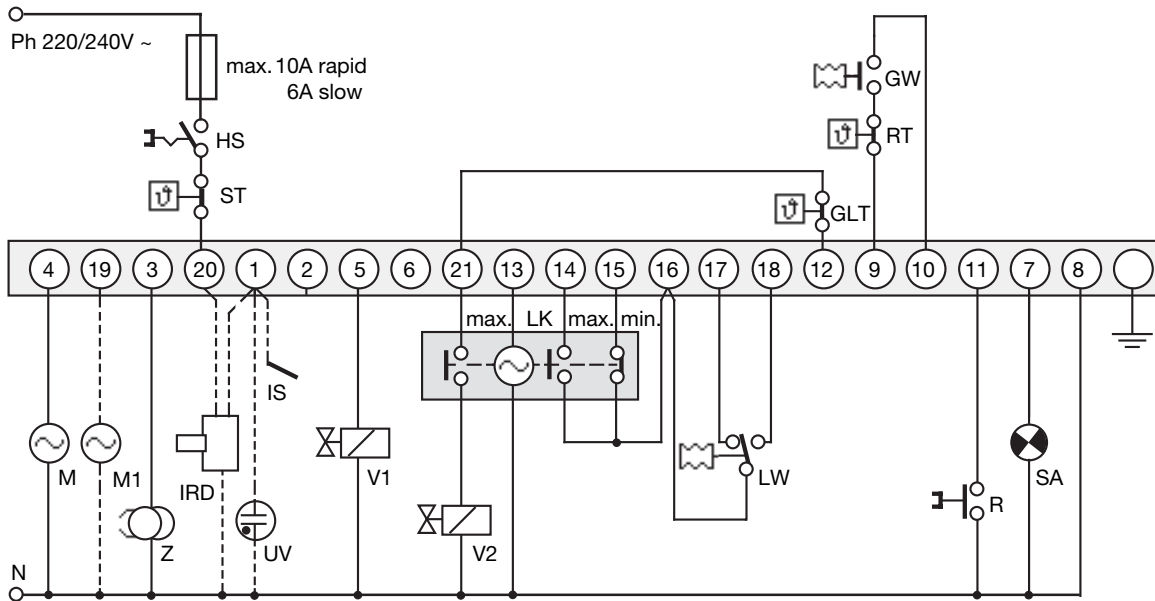

### BURNER WITH START-VALVE

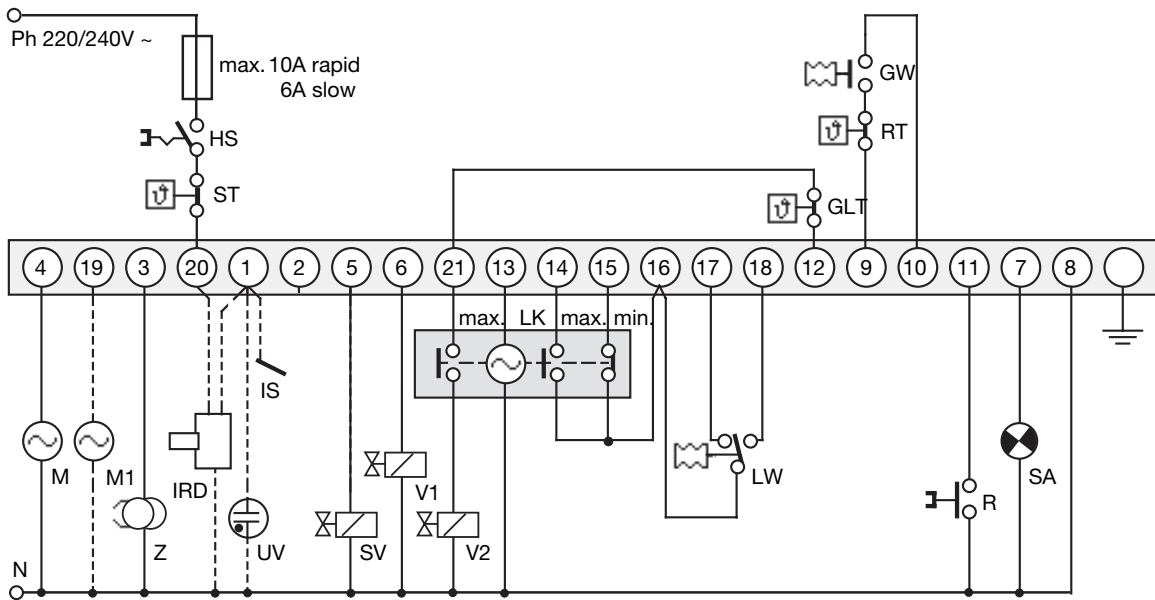

### 2 NOZZLE BURNER

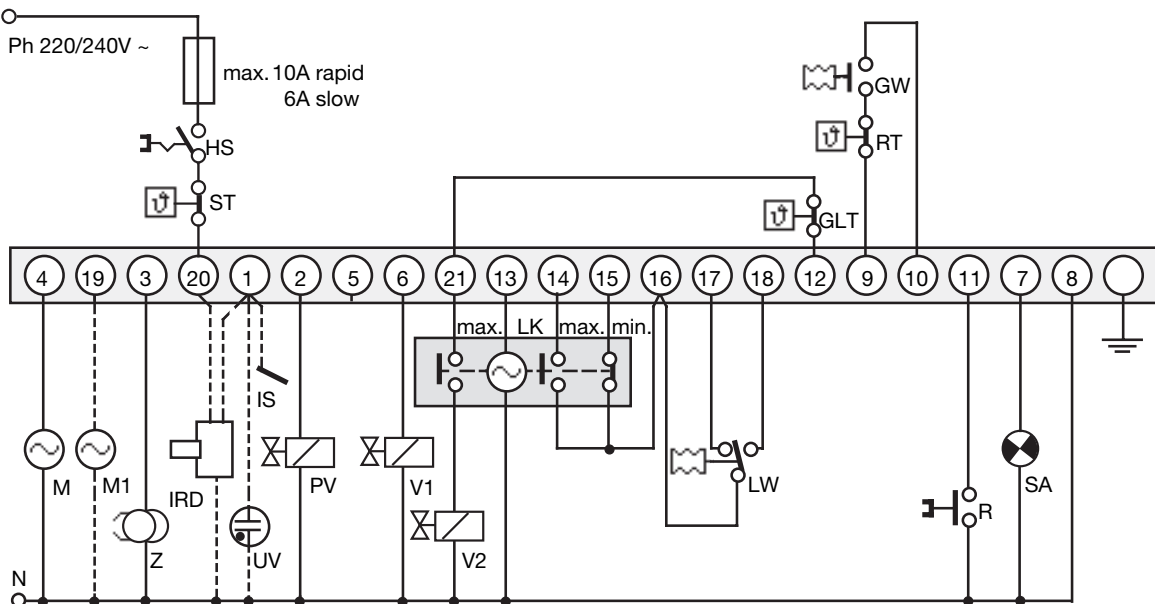

## SCHEMATIC DIAGRAMM

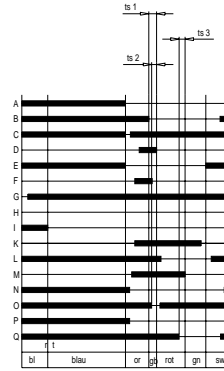
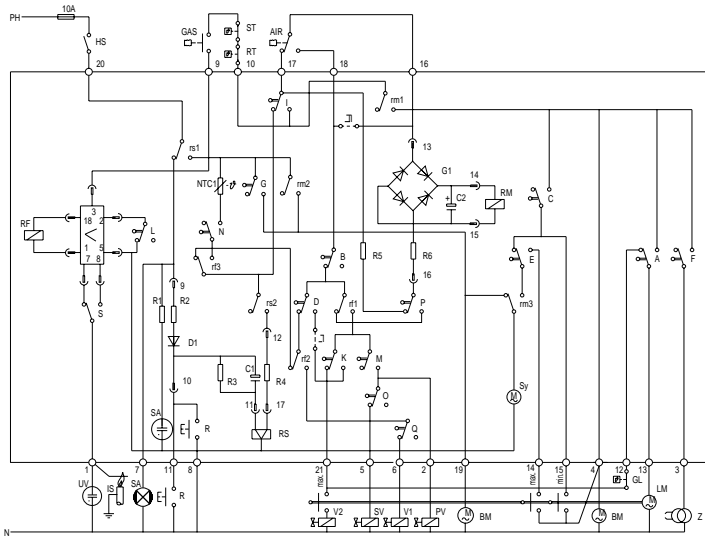

ts1 = Pilot valve safety interval  
 ts2 = Start valve safety interval  
 ts3 = Main valve 1 safety interval

I = cut for monitoring of the ignition spark  
 II = cut for additional switch contacts

## TMG 740-3 WITH SOCKET

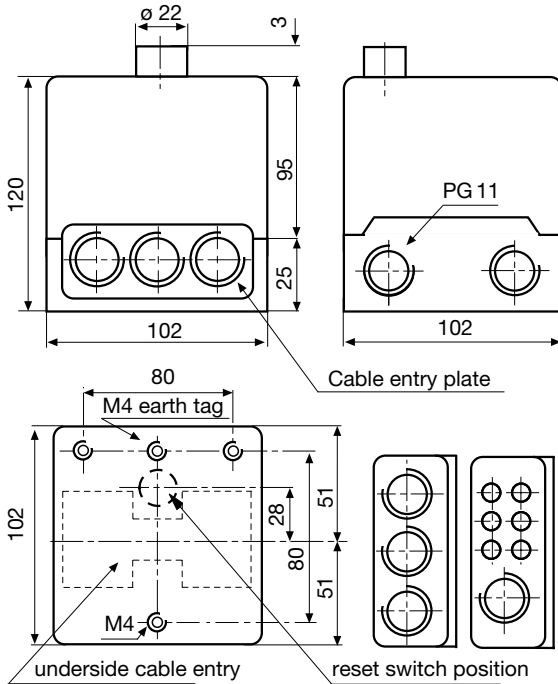

## UVZ 780 WITH SUPPORT

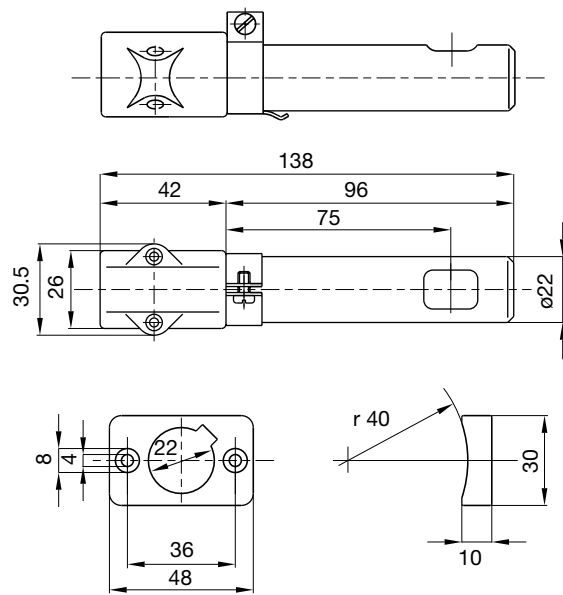

## ORDERING INFORMATION

ITEM	DESIGNATION	ITEM NO.
Burner control box	Type TMG 740-3 Mod. 32-32	08211
Socket	Socket TMG	70205
Insert plate	PG-plate	70502
optional	Cable entry plate	70501
Flame detector	UVZ 780 white	18814
or	UVZ 780 blue	18812
or	UVZ 780 red	18813
Flame detector	IRD 820	16201
Flame detector	IRD 1020 end-on viewing	16522
Flame detector	IRD 1020 side-on left	16523
Flame detector	IRD 1020 side-on right	16521
IRD mounting flange	IRD Holder M93	59093
Flame detector cable	3-wire, 0.6 m	7236001

The above ordering information refers to the standard version.  
 Special versions are also included in our product range.

Specifications subject to change without notice.

# TMG 740-3

A Honeywell Company

Satronic AG  
 Brüelstrasse 7  
 Postfach 324  
 CH-8157 Dielsdorf



Programme timing Model 33-33	secs.
pre-purge time supervised	30
pre-purge time with open air damper	37
response time for air-proving switch	9
pre-ignition time (short)	3.5
pre-ignition time (long)	46
safety time, pilot valve	3
safety time, start valve	3
safety time main valve	3
time to lockout during operation	<1
activated time of pilot	11
delay time to valve 1	9
delay time to valve 2	6
post-purge	8.5



## APPLICATION FEATURES

### 1. Information system – SGU 930i

The information system for the SGU 930i is controlled by a microprocessor. It is designed to report on every aspect of the burner control box's operation and on flame supervision. It records continuously every function of the control box. In the case of a lock-out, it offers a fault diagnosis and also stores the number of lock-outs which occur. The information is conveyed by means of an LED display and a serial interface. The micro-processor is used only for information purposes and is not connected with the safety functions of the control box. All signals which are checked by the information system are electrically isolated from the remainder of the control box circuit.

### 1.2. Reconstruction of the cycle and lockout-diagnosis

The information system uses certain signals of the control box to reconstruct the programme cycle. The system measures these signals at every stage of the cycle, checks them and decides if the next stage of the programme cycle has been reached.

### 1.3. Report

The programme cycle is observed and recorded continuously by the information system. As soon as a new stage is reached, a message is passed through the serial interface. The report line contains the time between "thermostat ON" and the function, the input and output signals, the strength of the flame signal in percentages (refer to 2.1) and a comment in simple language. The report lines for the lockouts are the same.

### 1.4 Report line format

Title.

Is printed when control thermostat switches on

```

          F L M S V Flame Cycle
h : m : s T I H P L Signal step
-----
hh:mm:ss .|.|. . . . . F xx% Text      reportline
hh:mm:ss

```

h : m : s hours :minutes :seconds – since Controlthermostat on

.|.|. Input/Output signals

| signal valid (e.g. thermostat is switched on)

. signal not valid (e.g. thermostat is switched off)

F flame relay

T control thermostat

L air proving switch

I safety relay

M synchronous motor

H main relay

S lockout relay

P pilot valve

V main valve 1

L high flame thermostat

F flame signal in xx% of max. current

Text programme stage or lockout in simple language



## 1.12 Supervision functions

The microprocessor in the information system is also used to carry out the following additional supervisory functions:

- supervision of the damper running time, and cause lock-out after >100 sec.
- supervision of the cam assembly during the safety times
- supervision of the control box life, a "heart-attack" occurs after 250 000 cycles (A warning is given after 240 000 cycles by the information system; but an emergency operation facility exists).

## 1.13 LED information system code

The dual-coloured LED display contains 5 independent LED's and is mounted on the front of the control box. With this visual information display, 11 different programme stages and 10 different lockout causes can be shown.

### programme stages

- start
- waiting for damper max. position
- pre-purge
- waiting for damper min. position
- flame establishment
- safety time
- operation stage 1
- operation stage 2
- post-purge
- return to start
- pause

### lockout-stages and warning

- air proving switch
- air proving switch at start
- stray light
- stray light at start
- flame not established
- flame extinguished
- damper running time
- safety time check
- approaching end-of-life
- heart attack

green  green flashing  red  red flashing

## 1.14 Serial Interface

The serial interface works according the RS 422 standard with power level between 0V and 5V. The data transfer is 9600 baud, bidirectional, 8 data bit, 1 stop bit, none parity bit.

The levels of the transmit signals are as follows:

- logical 1: transmit +  $\approx$  4.5V; transmit -  $\approx$  0.5V
- logical 0: transmit +  $\approx$  0.5V; transmit -  $\approx$  4.5V

The receive signals require the following levels:

- logical 1: difference betw. receive+ and receive- > 0.5V
- logical 0: difference betw. receive - and receive+ > 0.5V

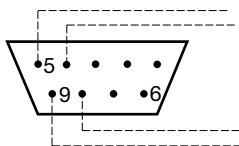

Overlay 9pol Dsub SGU:

- 4 Tx+ 5Tx-
- 8 Rx+ 9Rx-

## 1.15 Serial Interface

Generally speaking, any printer or computer with a serial interface type RS 422 can be connected to the SGU 930i, otherwise through a converter.

Possible configurations

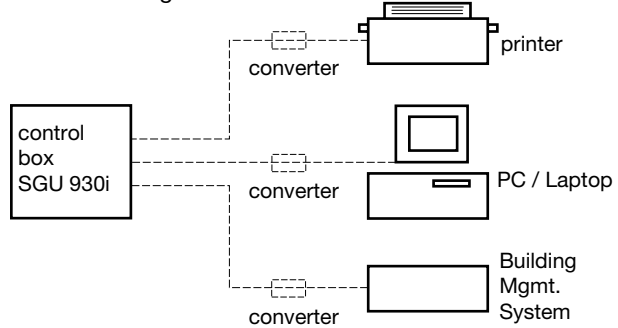

## 1.16 Configuration of the Info-system

Simple adjustments as well as requests for additional information can be done through a PC or laptop in conjunction with any terminal program. Below you will find the different commands which must be entered in capital letters confirmed by the return key. By writing to the report the info-system then will acknowledge the reception accordingly to the command. This message acts as a proof that the command has been received.

### SPRA1/SPRA2

The info-system is designed to handle two languages. The second language can be selected by the commands "SPRA1" for German and "SPRA2" for English.

### LWBRE/LWBRA

The operation of burners with no air pressure switch requires the bridging of the terminals 9, 10 and 11. This must be communicated to the info-system with the command "LWBRA" to avoid confusion. The command "LWBRA" returns the info-system to operation with air pressure switch.

### SGUIN

Print out of the additional information as well as of the lockout history.

### PROTZ

With this command one always will receive the print out of a protocol line informing about the current status of the burner. The info-system only delivers a protocol line when it comes to an other program step. During the operation it therefore could be the case, that there won't be any print out for a long time. With the above mentioned command "PROTZ" a protocol line always can be requested.

### PMOD1 / PMOD0

The "PMOD1" switches into the protocol mode 1. The Info system then delivers an extended protocol which includes all changes of the input signals. Usually the system works in the protocol mode 0. This mode only reports the single program steps. Not all proceedings are important for the program phases and therefore will not always being reported. With the mode 1 also these proceedings will be visible. The command "PMOD0" returns the system back to protocol mode 0.

## INIAN

This command is used to check the self control function of the processor software and therefore whether the processor software itself works correctly. When the command "INIAN" is sent to the info system the following response must be reported:

SGU INFORMATIONSSYSTEM  
VERSION 1.X.X

If this report does not appear, then the processor itself is defective.

## 2. Flame supervision

Flame supervision can be carried out by one of the following detectors:

- ionisation rod                      where the mains supply provides a neutral earth connection
- U-V cell                              type UVZ 780 for oil/gas- and dual fuel burners
- Infra-red flicker detector      type IRD 1020 for all type of burners

The different flame detectors are connected to separate terminals on the base, so that each detector is linked in the best possible way to the flame amplifier.

The flame signal display at the front of the control box is a 5-digit row of LED's. It displays continuously the value of the flame current and provides a constant indication of the flame signal strength. Any change in flame signal strength can be recognised immediately and corrective action can be taken without delay.

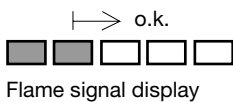

### 2.1 Relation between flame signal indication and probe current

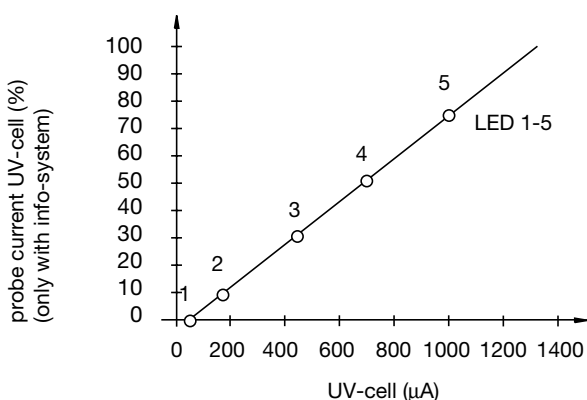
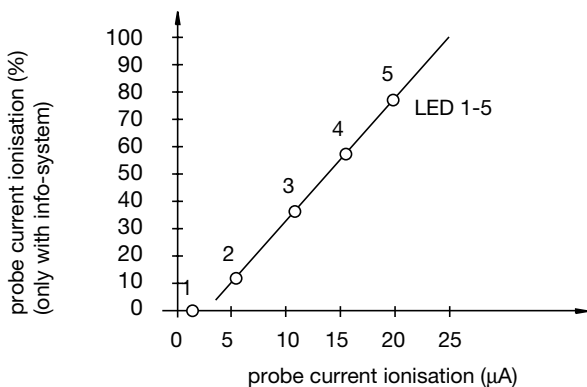

## 3. Control sequence for the burner

### 3.1 Selection of the programme

- The various control programmes can be selected by external selector switches or by the appropriate wiring to the base:
- long pre-ignition time (terminal 18) or short pre-ignition time terminal 19
  - lockout or recycling due to loss of flame, recycling is selected by a link between terminal 34 + 35
  - ignition spark detection by U-V cell, no link between terminal 36 + 37
  - fan motor with post-purge (terminal 17), or no post-purge terminal 16

### 3.2 Conditions to start

1. Control box at start position.  
Supply voltage connected to terminal 1 + N
2. Controlling thermostat calls for heat and safety interlocks are closed (between terminals 2 + 3)
3. Start command circuit SB, closed (terminals 7 + 8).  
These contacts may be open after approx. 6 secs.

### 3.3 Air damper control

With 3 separate output feeds, the air damper control can be set to either "closed", "low" air or "high" air positions. These monitored positions ensure "high" air for purging and "low" air before the initial release of fuel. Failure to reach both the "closed" and "high" air positions interrupt the control box sequence. If the air damper does not reach the required position within 100 seconds, the control box will go to lockout. Is no feed back from the air damper end position available, since no end contacts exist, then the terminals 28 and 2 must be connected together. Note, the air damper position is no longer controlled with this change. The output terminals of the air damper control are electrically isolated from the internal circuit of the control box after power is switched to the high flame or modulation stage thermostat. The modulation stage thermostat LR then controls the air damper, depending on the required firing rates of V1 (main flame) or V2 (high flame).

### 3.4 Air proving switch

The changeover contact of the air proving switch is connected to the safety circuit of the control box. Practically, a changeover contact for a switching current of 0.5 A will be used. If the contact is not in the "no air" position, the control sequence will not start. If this check is satisfied, the burner motor and air damper motor circuits are switched on. Combustion air supply must be proved within 9 seconds or the control box will go to lockout. Supervision of the combustion air supply ends with the interruption of the control thermostat circuit, the post-purge period is not monitored. To operate burner with no air proving switch, the terminals 9, 10 and 11 must be linked together.

Note, at SGU 930i this change must be told to the info-system (refer to 1.16 under LWBRE/LWBRA).

### 3.5 Valves

4 different valves can be connected, start valve or pilot valve, main valve (V1) and high flame or modulation stage valve (V2). On a single jet burner 3 firing rates can be achieved by use of the start valve and the main valves. Gas which flows through valves SV, V1 and V2 must join a common jet and the appropriate standards for the maximum firing rate of the start valve should be checked. Power is switched off to the pilot valve once the main flame is established. The maximum flow rate of the gas through the pilot valve is also limited by the relevant standard. It is not permitted to use the pilot valve and start valve at the same time.

### 3.6 Remote lockout facility

As a safety check, the control box can be put to lockout by closing the circuit between terminals 3 + 4. Reset from lockout can be achieved immediately by pressing the reset button at the front of the control box or by means of a remote switch.

## 4. Safety

The control boxes types SGU 930 and SGU 930i comply with the latest European standards - EN 230 for oil burner control boxes and EN 298 for gas burner control boxes. The control boxes also offer the following safety features in addition to those set down in EN 230 and EN 298:

### 4.1 Stray light check

The stray light check begins approximately 8 seconds after the end of a programme cycle by applying a higher voltage to the U-V cell. During a shutdown, a flame signal of more than several seconds duration will lead to a lockout. Any flame signal due to stray light or breakdown of the U-V cell during the pre-purge period will result in an immediate lockout.

### 4.2 Safety circuit

In the safety circuit, the input signals (e.g. from the air proving switch or flame relay) are checked by cam switches. This check begins after the start of the programme cycle. If the input signal does not match the required one, the safety circuit will be interrupted and lockout will occur immediately. The safety circuit has the advantage that it can be easily extended to add an unlimited number of input signals, which can be checked and are fail-safe.

### 4.3 Additional safety features

All output voltages to the valves are supplied via the cam switches and the flame relay as normal and in addition, via two independent contacts on the safety and main relays. Together with the lockout switch, five switches control the voltage supply to each of the valves.

The control box will not start unless the mains supply is above 175 V. If the voltage drops to 150 V during the control sequence, power to the burner is shut off. When power returns to normal, the control box will relight the burner.

The micro-processor in the information system of the SGU 930i does not affect the control functions in any way. However, the micro-processor provides additional safety functions by supervising the safety times and the age of the control box.

The cam assembly, which controls the different timings of the control programme, is monitored during the safety times by the information system. Any irregularity results in a lockout.

The cam and switch assembly of the SGU 930i has a guaranteed lifetime of 250 000 cycles. If a control box reaches this number of cycles, the information system induces a "heart attack". The control box will then run to the end of the programme cycle and lockout. After resetting this lockout, an additional start is possible in an "emergency".

## 5. Mounting and Installation

### 5.1 Base

In the new base with its 44 terminals, all burner components, detectors, control devices and other connections can be made with up to 2 wires per terminal, and is therefore more practical and easier to check. Despite the high number of terminals, the construction of the base allows easy access to each terminal. The terminal screws are enclosed in a metal shoe, thus preventing any damage to the wiring. Apart from the 38 terminals for the control box, additional terminals are also available. They are as follows:

- 7 extra neutral terminals, internally linked in the base to the main neutral terminal
- 6 earth terminals, linked to the main earth tag
- 16 knock-out cable entry holes  $\varnothing$  7 mm in diameter
- 4 knock-out cable entry holes with a PG 11 thread

To assist trouble free operation the main neutral connection terminal in the wiring base must be fully tightened.

A keying arrangement on the base prevents the possibility of the incorrect control box being fitted onto the base.



### 5.2 General

Any mounting attitude is possible, but it is recommended to mount it in a way so that the LED displays and the coloured programme indicator can be easily seen. The control box itself is resistant to spray water (IP 44), but the flame detectors may be sensitive to water and moisture. If the U-V cell UVZ 780 is used, good contact with the burner earth by means of the mounting flange is essential. Control box and flame detectors should be protected from harsh vibration.

Where flame supervision is by ionisation electrode, safety regulations require that it should be properly insulated in order to prevent the risk of an electric shock. A voltage in excess of 25 V between neutral and earth will prevent troublefree operation. In this case, use of an isolating transformer is recommended.

As listed under technical data, the maximum cable length for the flame detector should not be exceeded for trouble-free operation. It is not recommended to run the flame detector cables adjacent to power cables over long distances. Multi-cored cables should also not be used.

If during the test of the burner the click-rate (according to EN 55014) is higher than the max. allowed valve, a X2-capacitor of 0.1  $\mu$ F can be connected between terminal 1 and N.

# WIRING DIAGRAM

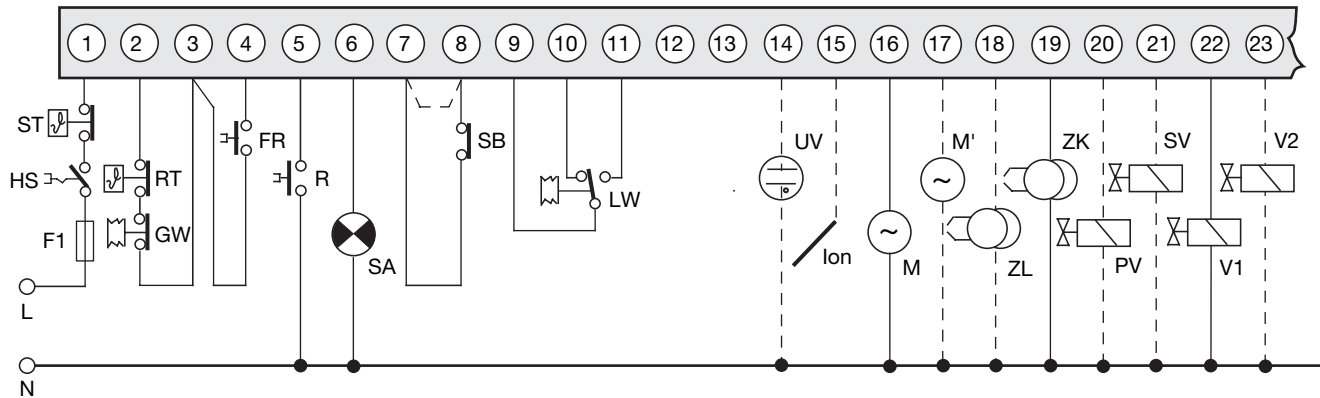

- HS mains switch
- LR high flame or modulation stage thermostat
- RT control thermostat
- ST limit thermostat
- GW gas pressure switch
- LW air pressure switch
- SB start interlock
- FR remote lockout
- R reset
- SA external lockout lamp
- M burner motor without post-purge
- M' burner motor with post-purge
- LK air damper motor
- Ion flame ionisation electrode
- UV U-V cell
- IRD I-R flicker detector
- PV pilot valve
- SV start valve
- V1 main valve
- V2 high flame or modulation stage valve
- ZK ignition (short)
- ZL ignition (long)
- L,N mains voltage
- F1 external fuse

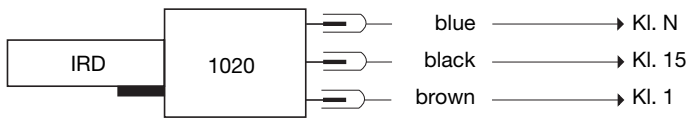
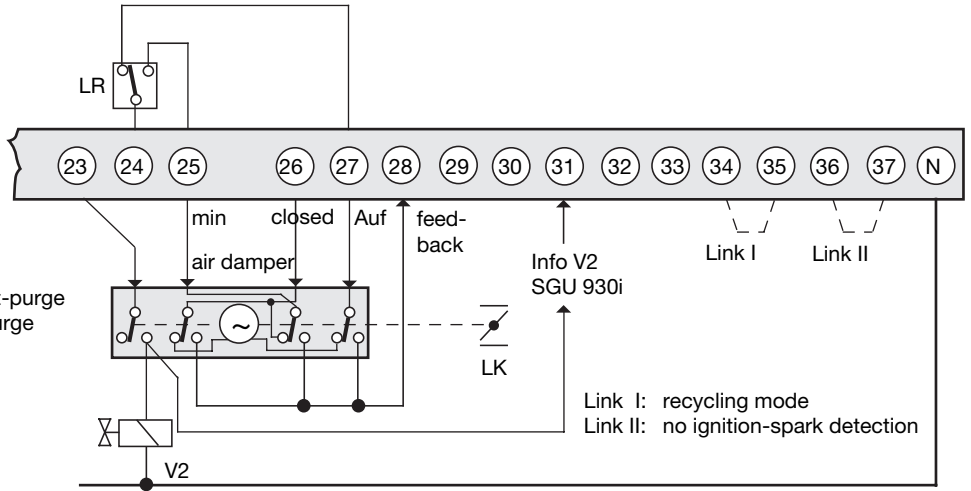

# PROGRAMME CYCLE

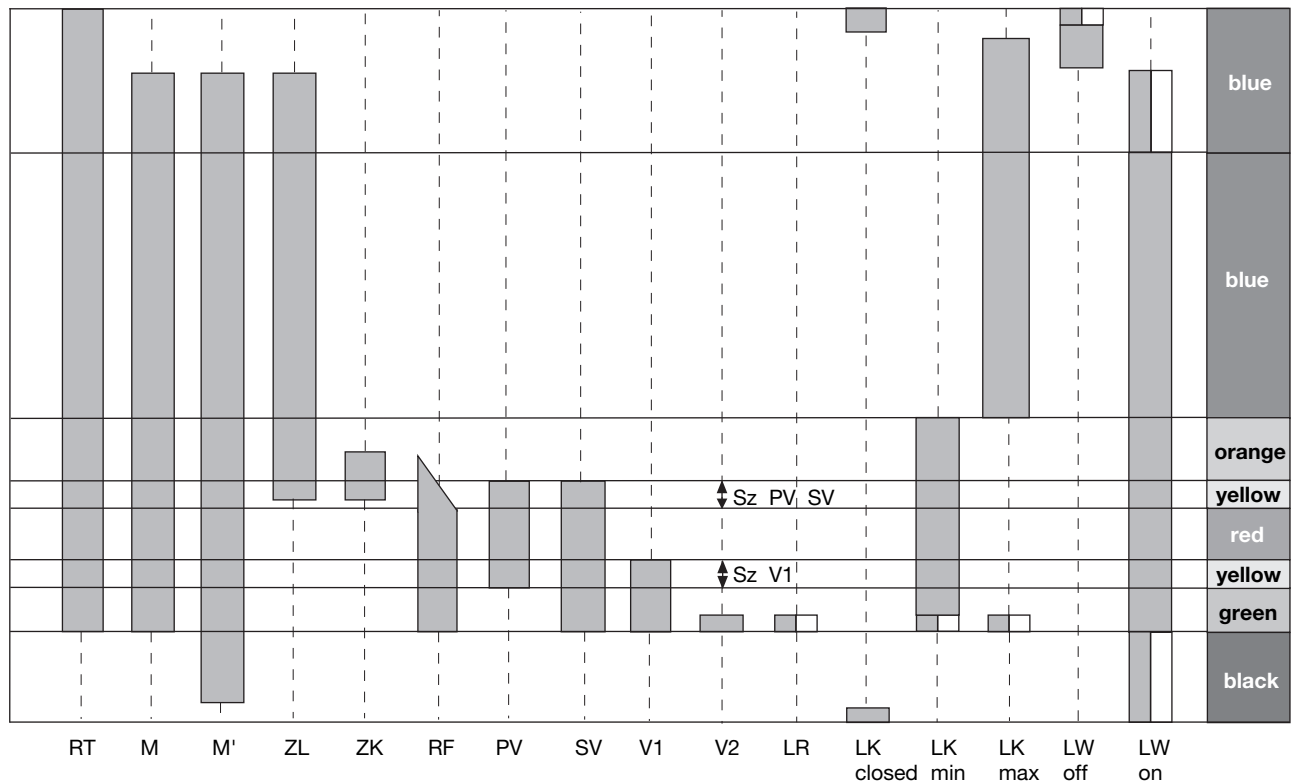

## INSTALLATION INSTRUCTIONS AND MAINTENANCE

### 1. Important notes

- Ensure that the control box is correctly wired in accordance with the appropriate diagram. Faulty or incorrect wiring could cause damage to the control box or installation.
- When mounting and wiring to the control box, the appropriate installation standards must be observed.
- The external fuse rating should be as stated in the technical data. The built-in fuse must only be exchanged by one of the same rating, T6.3 A slow, according to DIN 41571. If this is ignored, damage and hazardous conditions as a result of a short circuit could occur.
- In compliance with the relevant standards, a shutdown must occur at least once every 24 hours.
- Power must be switched off whenever removing or fitting the control box.
- Control boxes are safety equipment and therefore sealed. They must not be opened and any interference with the internal workings of the control box may have hazardous consequences.

### 2. Function test

The safety test for the flame detector must be carried out when the control box is installed, and at every routine maintenance check and after any lengthy break in operation.

- Shut off the fuel supply and link out the gas pressure switch and allow the burner to start:
  - at the expiry of the ignition safety time the control box must go to -> LOCKOUT
- When the burner is in the "run" position cover the flame detector:
  - LOCKOUT must occur if the lockout mode is selected
  - or burner will shutdown and attempt to relight if the recycling mode is selected

### 3. Trouble shooting

With the help of the information system, time consuming and expensive trouble shooting is no longer necessary. The recording of the programme cycle and the fault diagnosis are new "tools", resulting in less difficult fault finding procedures and saving on maintenance cost. If an interpretation of the lockout and information memory is not needed at the site of the application, the investigation can be done afterwards. The non-volatile memory can be later connected to a printer, laptop or a PC to analyse its contents while the burner is running with a replacement control box.

Another useful device to help follow the programme cycle and assist with trouble shooting is the built-in LED code display at the front of the control box. This shows all the various programme stages and lockouts or warnings. It is a continuous display and indicates at which stage the programme cycle has reached. When a lockout occurs, the reason for failure is shown on the display, it remains displayed until the control box is reset. Alongside the LED display, the most common codes are printed. Further decoding is listed in section 1.13 of this document. A detailed description of the complete information system can be found under the heading "APPLICATION FEATURES".

The coloured programme indicator of the cam assembly on control boxes without a built-in information system, at SGU 930, provides some help for trouble shooting. Faults during installation, operation or shutdown can be identified by this programme indicator. After lockout, it is recommended to make a note of the position of the indicator before re-setting.

The following list can be used for trouble shooting. Both cams of the SGU 930's cam assembly rotate synchronously and both programme indicators are identical.

Colour	Position	Fault	possible reason
BLUE	start	no start	no mains voltage, control or start circuit open
BLUE	after start	no start	air pressure switch not in "no air" position
BLUE	before red line	continuous	air damper not open (at "high" air position)
BLUE	red line	lockout	air pressure switch not in "air proved" position
BLUE	after red line	lockout	stray light, faulty flame detector
BLUE	after red line	burner stops	mains voltage <150 V
ORANGE	start	continuous	air damper not at "Low" air position
YELLOW	end	lockout	no flame established by start valve or pilot valve no flame signal or signal too weak ign. spark detection active without U-V cell no flame established after recycling
RED			
YELLOW	end	lockout	no flame signal after 2nd safety time or signal too weak (on 2-nozzle burners only)
GREEN	end	lockout	loss of flame in "run" position (in lockout mode) loss of combustion air supply
BLACK	end	lockout	stray light due to "after-burn" U-V cell failed the switch-off test due to aged or faulty U-V cell faulty flame detection circuit

### BURNER 1- OR 2-STAGE

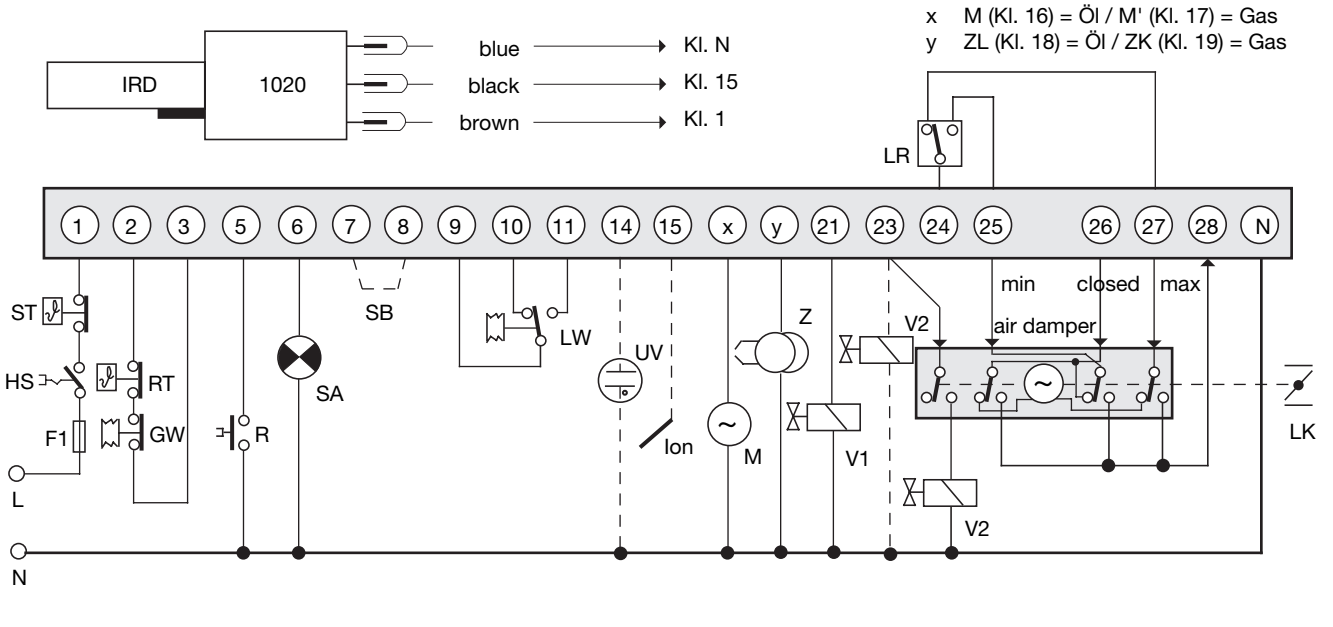

### BURNER WITH START-VALVE

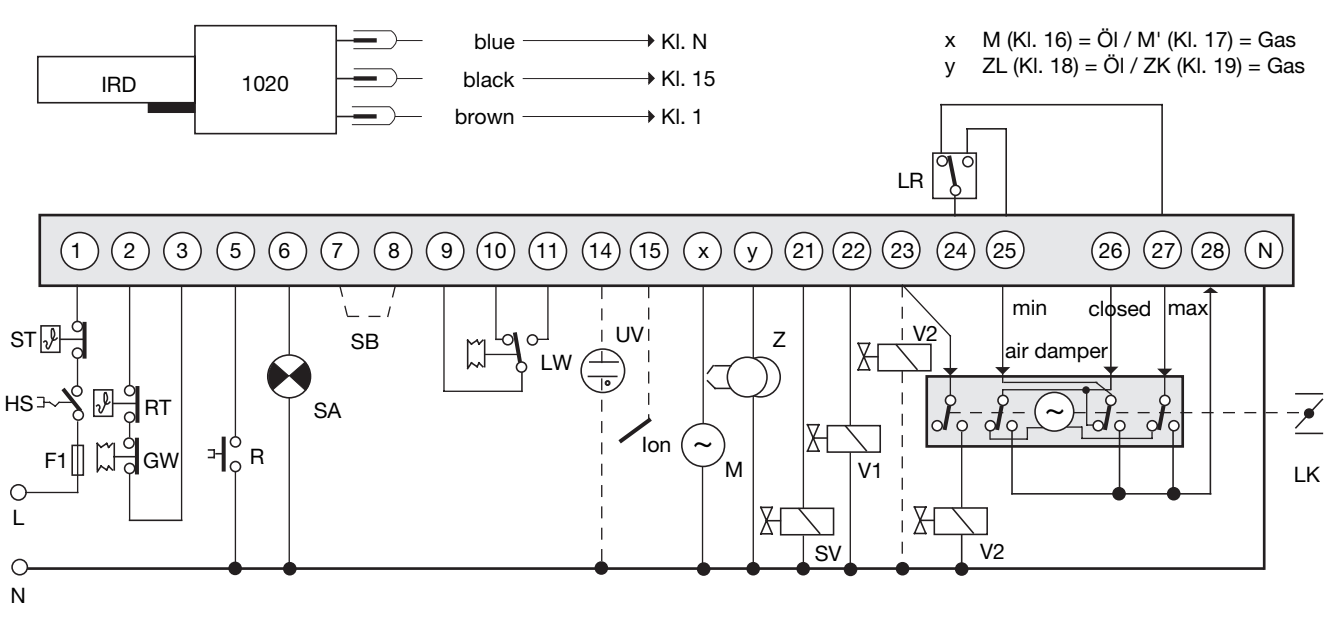

### BURNER WITH 2 NOZZLES

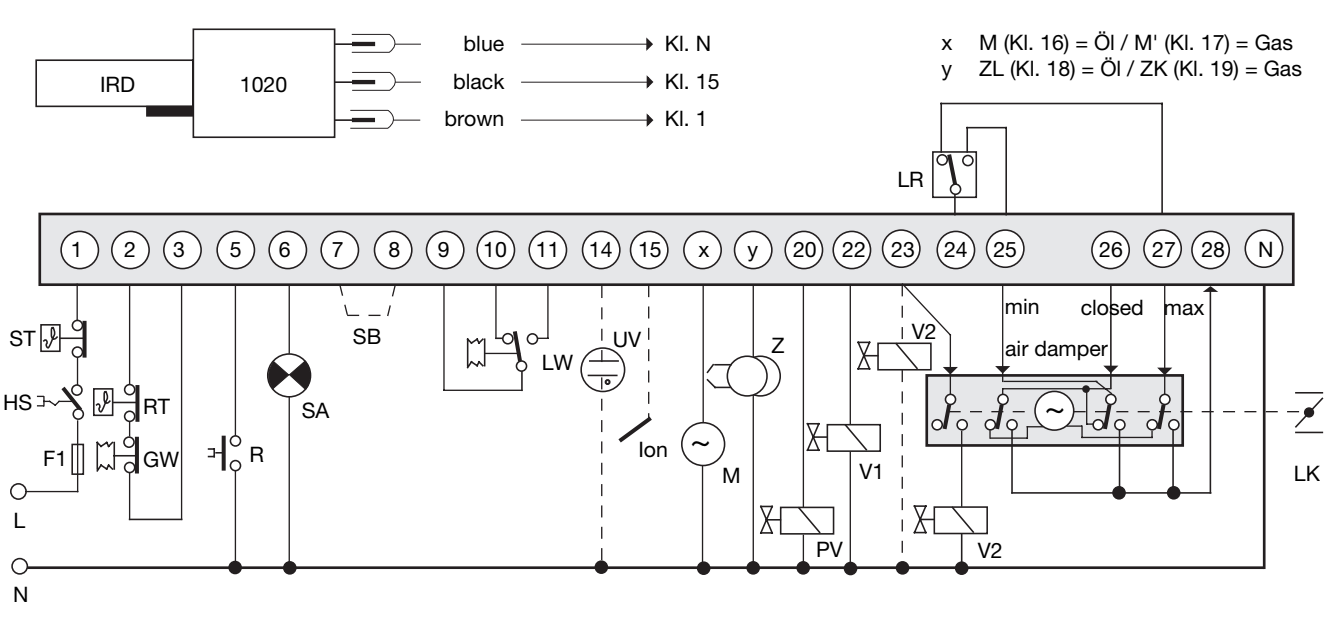

**UVZ 780**

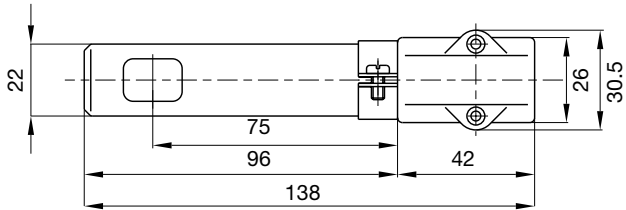

**IRD 1020**

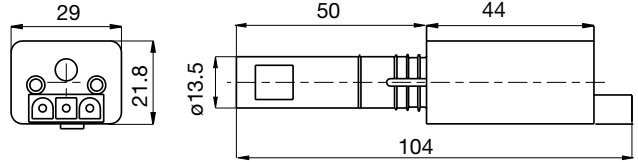

**SGU 930 AND SGU 930i WITH BASE**

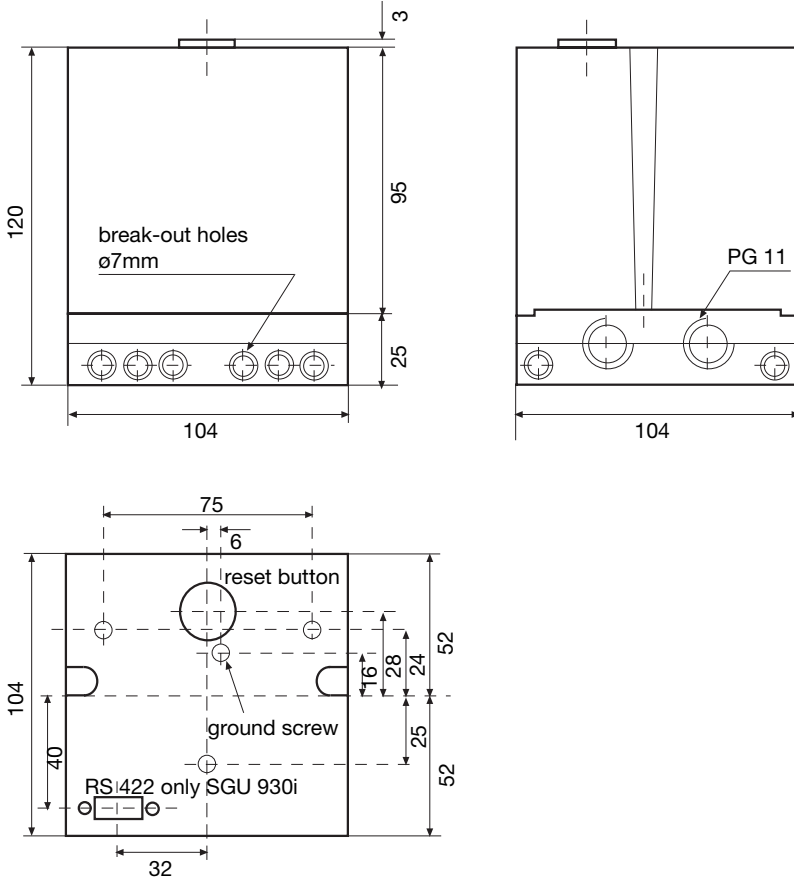

**MOUNTING FLANGE IRD**

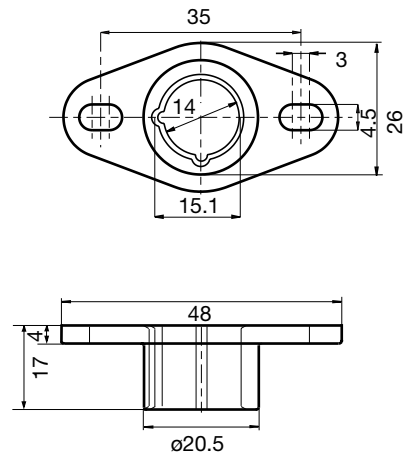

**MOUNTING FLANGE UVZ**

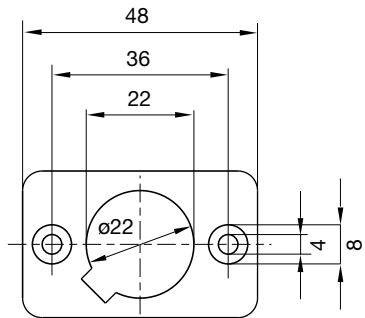

**ORDERING INFORMATION**

**ITEM**

**DESIGNATION**

**ITEM NO.**

Control box without info. system	SGU 930 Mod. 33-33	08910
Control box with info. system	SGU 930i Mod. 33-33	08911
Base	Base 930	70301
Flame detector	UVZ 780 blue	18812
Flame detector	UVZ 780 white	18814
Flame detector	UVZ 780 red	18813
Flame detector	IRD 1020 end-on viewing	16522
Flame detector	IRD 1020 side-on left	16523
Flame detector	IRD 1020 side-on right	16521
Mounting flange	UV Holder	18807
IRD mounting flange	IRD Holder M93	59093
Flame detector cable	3-wire, 0.5m	7236001

The above ordering information refers to the standard version.  
Special versions are also included in our product range.

Specifications subject to change without notice.

**SGU 930**  
**SGU 930i**

**satronic**

A Honeywell Company

Satronic AG  
Brüelstrasse 7  
Postfach 324  
CH-8157 Dielsdorf

## Gas Burner Safety Control

### For 2-stage atmospheric gas burners

#### Flame detection:

- Ionisation probe
- Infrared-flicker detector IRD 1020
- UV flame sensor UVD 971

### INTRODUCTION

The burner control box DKG 972 controls and supervises atmospheric burners for gas. They are approved and certified according to the applicable European standards and regulations.

The microprocessor-based programming sequence ensures extremely stable timings independent of voltage variations, ambient temperature and/or switch-on cycles. The built-in information system not only provides a continuous monitoring of the actual state of the box (very helpful especially for monitoring the start-up phase) but also informs about the cause of a possible lock out. The lock out cause is stored in such a way that it can be retrieved even after a power failure.

The control box is designed for maximum safety in case of fluctuations in the voltage supply. If the mains voltage drops below the permitted level, operation is interrupted and the control box automatically prevents the start sequence from being repeated. In this way, the safety of the system is not put at risk by a drop in the mains voltage. This low-voltage protection works not only during start-up but also permanently during operation.

### CONSTRUCTIONAL FEATURES

The control box circuitry is protected by a flame resistant, transparent plug-in type plastic housing. A central fixing screw locks the control box to the wiring base.

The plug-in control box incorporates the microprocessor based timer, flame check and reset circuits.

Manual reset from lock out and set to lock out is provided by a push button with an integrated LED information system. A variety of cable entry points provides complete flexibility for electrical wiring.

The wiring base S98 is equipped with spare- and extraterminals and allows together with a variety of cable entry points utmost flexibility of electrical wiring.

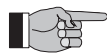

The DKG 972 are compatible with the TFI 812. Different are only the pre- and post-ignition times.

Max. heating power according the limits in the Gas Appliance Directive.



### TECHNICAL DATA

Operating voltage	220 / 240 V (-15... +10%) 50 Hz (±5%)
Fuse rating	10 A fast, 6 A slow
Power consumption	ca. 15 VA
Max. load per output	
- term. 3 ignition trafo	1.0 A, cos φ 0.2
- term. 5 + 6 solenoid valves	0.5 A, cos φ 0.4
- term. 7 alarm indicator	0.5 A, cos φ 0.4
total load	4.0 A, cos φ 0.4 max. 6 A during 0,5 sec
Reset time from lock out	none
Sensitivity	1 µA
min. ionisation current required	1.5 µA
Sensitivity for stray light	0.4 µA
Ionisation probe insulation	probe - earth
greater than 50 MΩ	
Stray capacitance	probe- earth
less then 1000 pF	
max. cable length	< 3 m
Flame detectors	
IRD 1020	side-on or end-on viewing
UVD 971	end-on viewing
Weight incl. Wiring base	190 g
Mounting position	any
Protection class	IP 40
Approved ambient parameter	
for control and flame detector	max. 95% at 30° C
- for operation	-20° C... +60° C
- for storage	-20° C... +80° C
Build-up of ice, penetration of	
water and condensing water are	inadmissible
Approvals according	
to European standards	EN 298 and EN 230, as well as all other relevant Directives and standards
Classified acc. to EN 298	FTLLXN

### Timings (sec.)

Model	waiting time start <b>tw</b>	pre-ignition time <b>tvz</b>	Stray light monitoring <b>tf</b>	safety time <b>ts</b>	post-ignitiontime <b>tn</b>	delay 2nd-stage <b>tv2</b>
<b>05</b>	12	3	5	5	4.5	25
<b>10</b>	12	3	5	10	9.5	25
<b>20</b>	12	3	5	20	19.5	25

## APPLICATION FEATURES

### 1. Information system

The information system is microprocessor based and reports on all aspects of burner control box operation and flame supervision. It informs continuously about the actual programming sequence the unit is just performing. Besides monitoring of the programming sequence it also allows to identify errors during start-up of operation without any additional testing devices. The automatically performed diagnosis is a valuable tool which facilitates service/maintenance work and therefore saves costs. The analyses of the error cause can be done directly on stage or if not possible afterwards as the lock out reason is stored in a non-volatile lock out mode memory.

The information system communicates with the outside world using a LED (the used Flash-Code is similar to the Morse-Code). The messages are optically transmitted by a appropriately flashing LED. Using an additional terminal (optional), the messages can be recorded and displayed in easy readable form.

#### 1.1 Programming sequence display

The built-in microprocessor controls not only the programming sequence but the information system too. The individual phases of the programming sequence are displayed as Flash-Code.

The following messages can be distinguished:

Message	Flash-Code
waiting time tw	.
pre-ignition tvz	.
safety time ts post ignition tn	■     .
delay time to valve V2 tv2	■       .
running	_
low mains voltage	■ ■ _

#### Description

x = short pulse

z = long pulse

. = short pause

\_ = long pause

### 1.2 Lock-out diagnoses

In case of a failure the LED is permanently illuminated. Every 10 seconds the illumination is interrupted by a flash code, which indicates the cause of the error. Therefore the following sequence is performed which is repeated as long as the unit is not reset.

Sequence:

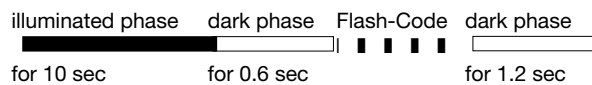

#### Error diagnosis

Error message	Flash-Code	Possible fault
lockout	■ ■ ■ ■	within lock out safety time no flame establishment
stray light	■ ■ ■	stray light during monitored phase, detector may be faulty

#### Flash-Code for manual lock out

manual/external	■ ■ ■ ■ _ ■ ■ ■ ■ ■
lock out (see also 3. lock out and reset)	

### 2. Flame detection

The following types of flame detectors are suitable:

- Ionisation probe, temperature resistant material, well insulated (material and insulation same as for ignition electrode).
- Infrared-flicker detector type IRD 1020 with mounting flange M 93 or the UV solid state flame sensor UVD 971. Flame detection using an ionisation probe is only possible in conjunction with mains supplies which provides a neutral earth connection. Connecting the IRD 1020 or UVD 971 the correct wiring has to be observed.

#### 2.1 Stray light monitoring

The stray light check is performed at the end of the pre-purge time for thr duration as mentioned in the technical datas.

### 3. Lock out and reset

The unit can be reset or brought into lock out mode in two different ways:

#### Internal

In the lock out case the unit can be reset by pushing the built-in button meaning a new start-up cycle is performed.

#### External

Instead of using the built-in lock out button the same function can be achieved by using an external button which connects terminal 9 with A (see also circuit and block diagram).

If the pushbutton (internal or external) is pressed during normal operation or during the start sequence for more than 3 sec. and afterwards released, the control box will perform a shutdown.



#### Please note

The unit can only be brought to lockout mode or be reset if power is applied to the unit.

### 4. Low-voltage protection

The mains voltage has to be more than  $187 V_{\text{eff}}$  in order to allow the unit to perform a start-up.

The mains voltage is not only monitored in the start-up phase but also permanently during operation. If the voltage drops below  $< 160 V_{\text{eff}}$  during start-up or run time the control box goes into lock out mode. If the voltage rises again, the control box performs automatically a start-up as soon as the mains voltage is  $> 187 V_{\text{eff}}$ .

### 5. Safety

The design and control sequence of the DKG 972 controls will comply with the currently applicable standards and regulations (see also TECHNICAL DATA).

### 6. Mounting and electrical wiring

Wiring base:

- 3 earth terminals with additional terminal for burner earthing
- 3 neutral terminals with internal permanent connection to neutral terminal 8
- 2 independant spare terminals (S1 and S2)
- extra terminals A, B and C are standard
- 2 slide-in plates and 2 easy knock out holes (PG11 thread) plus 2 knock out holes in the base bottom facilitate the base wiring

The digital controls are ideally wired on the new wiring bases S98, which are equipped with (terminals B and C are only for some special types of DMO or DMG) terminal A, which is used for the remote reset / remote lockout functions.

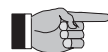

#### Please note

To assist trouble-free operation the main neutral connection terminal in the wiring base must be fully tightened. The terminal screws are already in the undone position. To connect a wire to the terminal, the screw only needs to be fastened.

General: The control box and detector probes should not be subjected to excessive vibration.

## INSTALLATION INSTRUCTIONS AND MAINTENANCE

### 1. Important notes

- The controls must be installed by qualified personnel only. The relevant national regulations have to be observed.
- On commissioning the wiring has to be carefully checked according to the appropriate diagram. Incorrect wiring can damage the unit and endanger the installation.
- The fuse rating has to ensure that the limits specified in TECHNICAL DATA will not be exceeded. If these precautions are not observed, the effect of a short circuit can cause severe damage to the control and installation.
- For safety reasons a minimum of one control shutdown every 24 hours has to be observed.
- Disconnect the mains before the control box is plugged in or out.
- The control box is a safety device and must not be opened!

### 2. Function control

For safety reasons the flame detection system should be tested on commissioning the installation as well as after a service or longer shut-down.

- Attempt to start with gas valve closed:
  - At the end of the safety interval  
-> Lockout
- After a normal start, with the burner in operation, close the gas valve:
  - At the end of the safety interval, system attempts to restart  
-> Lockout

### 3. Fault finding

The built-in information system facilitates the trouble shooting in the case of problems occurring during start-up or during operation.

A list of possible lock out messages can be found in APPLICATION FEATURES chapter 1.2.

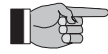

#### Please note:

**The control box is locked in lock out mode and the reason for the lock out is displayed until the control box is reset, either by an internal or external reset (see also subject "3. Lock out and reset").**

Removing the control box from its wiring base or by interrupting the supply line may not reset a lock out. Therefore, by applying power, it needs 2-3 secs. before the control box goes to lock out again and the cause of the last lock out.

<b>Error</b>	<b>Possible fault</b>
Burner not working	- Thermostat circuit open - Faulty electrical wiring - mains voltage < 187 V
After 2-3 secs. after applying power, the unit goes to lock out	- Control box has not been reset
Burner starts, flame not established, lock out	- No ignition or no fuel
Burner starts, flame established, after safety time, lock out	- no or too low flame signal (min. valves see TECHNICAL DATA) - wrongly wired, phase and neutral reversed - Ionisation probe dirty, broken or has contact to frame ground - too little light on flame sensor (IRD)

**CIRCUIT AND TIMING DIAGRAM DKG 972**

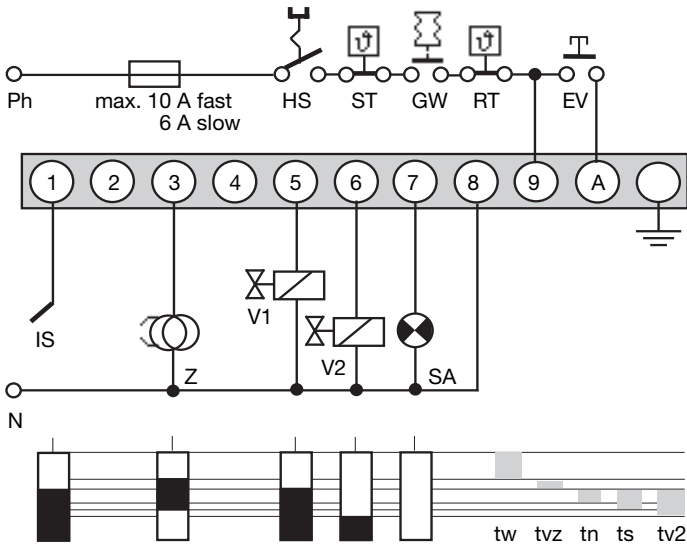

- HS Mains switch
  - GW Gas proving switch
  - ST Limit thermostat
  - RT Control thermostat
  - EV External reset and lock out button
  - IS Ionisation probe (IRD 1020, UVD 971 see separate diagram)
  - Z Ignition
  - V1 Solenoid valve, 1st-stage
  - V2 Solenoid valve, 2nd-stage
  - SA External lock out signal
- 
- tw Waiting time
  - tvz Pre-ignition time
  - tn Post-ignition
  - ts Safety time
  - tv2 2nd-stage delay

**IRD- OR UVD CONNECTION**

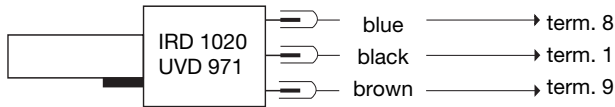

**BLOCK DIAGRAM DKG 972**

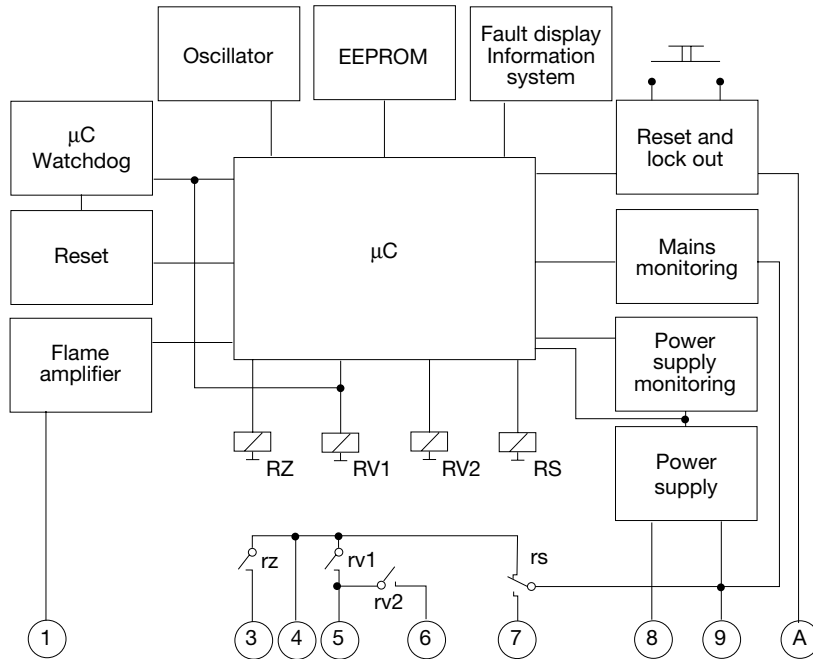

**DKG 972 AND SOCKET**

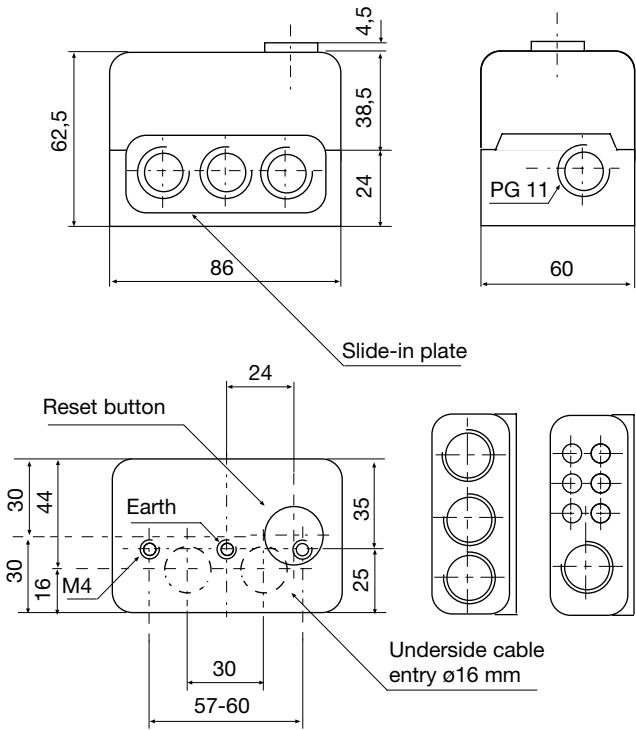

**UVD 971**

**IRD 1020**

**HOLDER M 93 FOR IRD**

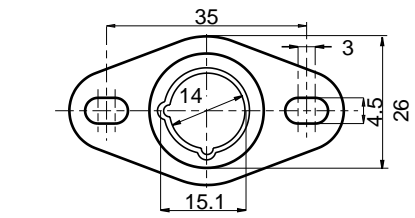
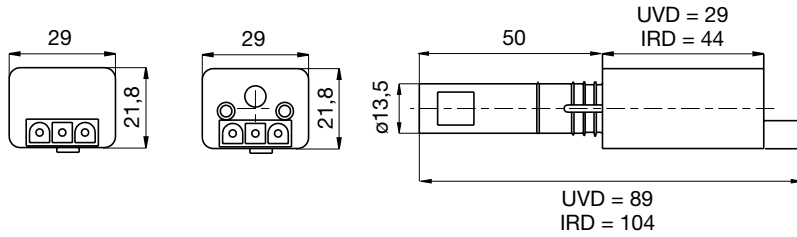

**VARIATION IRD**

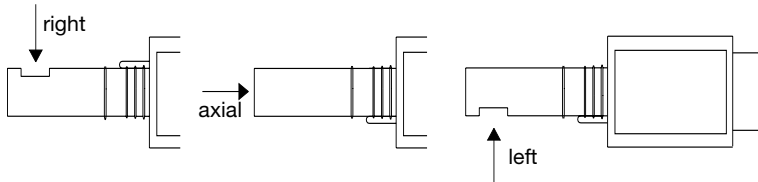

**ORDERING INFORMATION**

ITEM	DESIGNATION	ITEM NO.
Control box	DKG 972 Mod. 5	0332005
Control box	DKG 972 Mod. 10	0332010
Control box	DKG 972 Mod. 20	0332020
Socket	Wiring base S98	75310
Insert plate	PG-Plate	70502
optional	Cable entry plate	70501
Flame detector	IRD 1020 end-on	16522
Flame detector	IRD 1020 left	16523
Flame detector	IRD 1020 right	16521
optional	UVD 971	16722
Support for IRD	Holder M93 for IRD 1020	59093
Support for UVD	Holder M74 for UVD	59074
Connection cable	Plug type, 3 core cable, 0.6 m with tag wire ends	7236001

The above ordering information refers to the standard version. Special versions are also included in our product range.

Specifications subject to change without notice

**DKG 972**



A Honeywell Company

Satronic AG  
Brüelstrasse 7  
Postfach 324  
CH-8157 Dielsdorf

## Gas Burner Safety Control

**For 2-stage forced draught and combi oil/gas burners**

**Possible flame detectors:**

- Ionisation probe
- Infrared flicker detector 1020
- UV flame sensor UVD 971

### INTRODUCTION

The burner control box DMG 970 controls and supervises power burner for gas and dual fuel. The control box is approved and certified according the relevant European standards. The use on direct air heaters according DIN 4794 is also possible.

The microprocessor- based programming sequence ensures extremely stable timings independent of voltage variations, ambient temperature and/or switch-on cycles. The built-in information system not only provides a continuous monitoring of the actual state of the box (very helpful especially for monitoring the start-up phase) but also informs about the cause of a possible lock out. The lock out cause is stored in such a way that it can be retrieved even after a power failure.

The control box is designed for maximum safety in case of fluctuations in the voltage supply. If the mains voltage drops below the permitted level, operation is interrupted and the control box automatically prevents the start sequence from being repeated. In this way, the safety of the system is not put at risk by a drop in the mains voltage. This low-voltage protection works not only during start-up but also permanently during operation.

### CONSTRUCTIONAL FEATURES

Microprocessor, electronic components, output relays and flame amplifier are placed on two printed circuit boards. These plus the lockout- and reset circuit are well protected inside a flame resistant, plug-in type plastic housing.

The reset switch for reset / remote lockout with its built-in LED for displaying the information system plus the central fixing screw are placed on top of the housing.

The wiring base S98 is equipped with spare- and extraterminals and allows together with a variety of cable entry points utmost flexibility of electrical wiring.

The DMG 970 is functionally compatible to MMI 810 and MMI 810.1

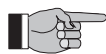

Please note: Is the DMG 970 to be used to replace the MMI 810 or 810.1, care has to be taken to make sure the air proving switch (LW) is wired between terminals 4 and 7 and not like on the MMI between 5 and 7.



### TECHNICAL DATA

Operating voltage	220 / 240 V (-15... +10%)
	50 Hz (±5%)
Fuse rating	10 A fast, 6 A slow
Power consumption	ca. 15 VA
Max. load per output	
- term. 3 ignition trafo	1.5 A, cos φ 0.2
- term. 4 motor	2.0 A, cos φ 0.4
- term. 5 + 6 solenoid valves	1.0 A, cos φ 0.4
- term. B alarm indicator	1.0 A, cos φ 0.4
total load	5.0 A, cos φ 0.4
	max. 10 A during 0.5 sec
Air proving switch	1 working contact 4 A, 230V
Stray light monitoring	5 sec
Sensitivity (operation)	1 µA
Min. required ion. current	1.5 µA
Sensitivity for stray light	0.4µA
Ionisation probe insulation	Probe - earth greater than 50 MΩ
	Probe - earth less than 1000 pF
stray capacity	< 3 m
cable lenght	
Flame detectors	
IRD 1020	side-on or end-on viewing
UVD 971	end-on viewing
Weight incl. Wiring base	190 g
Mounting position	any
Protection class	IP 40
Approved ambient parameter	
for control and flame detector	max. 95% at 30° C
- for operation	-20° C... +60° C
- for storage	-20° C... +80° C
Build-up of ice, penetration of water and condensing water are inadmissible	
Approvals according to European standards	EN 298 and EN 230, as well as all other relevant Directives and standards
	FLLXN
Classified acc. to EN 298	

### Timings (sec.)

Model	waiting time start	max. reaction time for air proving switch <b>tlw</b>	supervised pre-purge time <b>tv1</b>	pre-ignition time <b>tvz</b>	ignition time total <b>tz</b>	Stray light monitoring <b>tf</b>	safety time <b>ts</b>	delay 2nd-stage <b>tv2</b>
<b>01</b>	0	60	24	3	5.5	5	3	12.5
<b>02</b>	0	60	24	3	7.5	5	5	14.5
<b>03</b>	0	60	40	3	5.5	5	3	12.5

## APPLICATION FEATURES

### 1. Information system

The information system is microprocessor based and reports on all aspects of burner control box operation and flame supervision. It informs continuously about the actual programming sequence the unit is just performing. Besides monitoring of the programming sequence it also allows to identify errors during start-up of operation without any additional testing devices. The automatically performed diagnosis is a valuable tool which facilitates service/maintenance work and therefore saves costs. The analyses of the error cause can be done directly on stage or if not possible afterwards as the lock out reason is stored in a non-volatile lock out mode memory.

The information system communicates with the outside world using a LED (the used Flash-Code is similar to the Morse-Code). The messages are optically transmitted by a appropriately flashing LED. Using an additional terminal (optional), the messages can be recorded and displayed in easy readable form.

#### 1.1 Programming sequence display

The built-in microprocessor controls not only the programming sequence but the information system too. The individual phases of the programming sequence are displayed as Flash-Code.

The following messages can be distinguished:

Message	Flash-Code
waiting for air proving switch	.
pre-purge tv1	.
pre-ignition tvz	.
safety time ts	■   .
delay 2nd stage tv2	■     .
running	_
low mains voltage	■ ■ _

#### Description

| = short pulse

■ = long pulse

. = short pause

\_ = long pause

#### 1.2 Lock-out diagnoses

In case of a failure the LED is permanently illuminated. Every 10 seconds the illumination is interrupted by a flash code, which indicates the cause of the error. Therefore the following sequence is performed which is repeated as long as the unit is not reset.

Sequence:

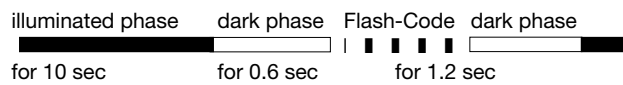

#### Error diagnosis

Error message	Flash-Code	Possible fault
lock out safety time	■ ■ ■ ■	within lock out safety time no flame establishment
stray light	■ ■ ■	stray light during monitored phase, detector may be faulty
air proving switch in closed position	■ ■	air proving switch contact welded
air proving switch time-out	■ ■	air proving switch does not close within specified time
air proving switch opened	■	air proving switch opens during start or operation
loss of flame	■ ■ ■ ■	loss of flame during operation

#### Flash-Code for manual lock out

anual/external | | ■ ■ ■ \_ ■ ■ ■ ■ ■  
lock out  
(see also 3. lock out and reset)

## 2. Flame detection

The following types of flame detectors are suitable:

- Ionisation probe, temperature resistant material, well insulated (material and insulation same as for ignition electrode).
  - Infrared-flicker detector type IRD 1020 with mounting flange M 93 or the UV solid state flame sensor UVD 971.
- Flame detection using an ionisation probe is only possible in conjunction with mains supplies which provides a neutral earth connection. Connecting the IRD 1020 or UVD 971 the correct wiring has to be observed.

### 2.1 Stray light monitoring

The stray light check is performed at the end of the pre-purge time for thr duration as mentioned in the technical datas.

### 3. Lock out and reset

The unit can be reset or brought into lock out mode in two different ways:

#### Internal

In the lock out case the unit can be reset by pushing the built-in button meaning a new start-up cycle is performed.

#### External

Instead of using the built-in lock out button the same function can be achieved by using an external button which connects terminal 9 with A (see also circuit and block diagram).

If the pushbutton (internal or external) is pressed during normal operation or during the start sequence for more than 3 sec. and afterwards released, the control box will perform a shutdown.



#### Please note

The unit can only be brought to lockout mode or be reset if power is applied to the unit.

### 4. Low-voltage protection

The mains voltage has to be more than  $187 V_{\text{eff}}$  in order to allow the unit to perform a start-up.

The mains voltage is not only monitored in the start-up phase but also permanently during operation. If the voltage drops below  $< 160 V_{\text{eff}}$  during start-up or run time the control box goes into lock out mode. If the voltage rises again, the control box performs automatically a start-up as soon as the mains voltage is  $> 187 V_{\text{eff}}$ .

### 5. Safety

The design and control sequence of the DMG 970 controls will comply with the currently applicable standards and regulations (see also TECHNICAL DATA).

### 6. Mounting and electrical wiring

Wiring base:

- 3 earth terminals with additional terminal for burner earthing
- 3 neutral terminals with internal permanent connection to neutral terminal 8
- 2 independant spare terminals (S1 and S2)
- extra terminals A, B and C are standard
- 2 slide-in plates and 2 easy knock out holes (PG11 thread) plus 2 knock out holes in the base bottom facilitate the base wiring

The digital controls are ideally wired on the new wiring bases S98, which are equipped with (terminals B and C are only for some special types of DMO or DMG) terminal A, which is used for the remote reset / remote lockout functions.

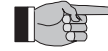

#### Please note

To assist trouble-free operation the main neutral connection terminal in the wiring base must be fully tightened. The terminal screws are already in the undone position. To connect a wire to the terminal, the screw only needs to be fastened.

General: The control box and detector probes should not be subjected to excessive vibration.

## INSTALLATION INSTRUCTIONS AND MAINTENANCE

### 1. Important notes

- The controls must be installed by qualified personnel only. The relevant national regulations have to be observed.
- On commissioning the wiring has to be carefully checked according to the appropriate diagram. Incorrect wiring can damage the unit and endanger the installation.
- The fuse rating has to ensure that the limits specified in TECHNICAL DATA will not be exceeded. If these precautions are not observed, the effect of a short circuit can cause severe damage to the control and installation.
- For safety reasons a minimum of one control shutdown per 24 hours has to be observed.
- Disconnect the mains before the control box is plugged in or out.
- The control box is a safety device and must not be opened!

### 2. Function control

For safety reasons the flame detection system should be tested on commissioning the installation as well as after a service or longer shut-down.

- Start-up with closed gas valve
  - After lock out safety time is over the unit has to go into lock out mode!
- Normal start-up, when burner is running, close gas valve
  - After loss of flame, the control box has to go into lockout mode
- Normal start-up, during pre-purge or operation, interrupt the air proving switch
  - The control box has to perform a lockout immediately
- Bridged air proving switch before start
  - the fan motor switches on for approx. 2 - 3 secs, followed by a lockout. After 10 secs., this quick lockout is reset by the control box and a second start attempt follows (fan motor switches on for approx. 2 - 3 secs.). A standard lockout appears if the air proving switch (LW) contact is still in its closed position (e.g. welded contacts). Has the air proving switch (LW) changed to its open position in the meantime (e.g. by a run down motor), a normal start sequence follows.

### 3. Fault finding

The built-in information system facilitates the trouble shooting in the case of problems occurring during start-up or during operation.

A list of possible lock out messages can be found in APPLICATION FEATURES chapter 1.2.

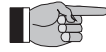

#### Please note:

**The control box is locked in lock out mode and the reason for the lock out is displayed until the control box is reset, either by an internal or external reset (see also subject "3. Lock out and reset").**

Removing the control box from its wiring base or by interrupting the supply line may not reset a lock out. Therefore, by applying power, the fan motor switches on for 2-3 secs. before the control box goes to lock out again and the cause of the last lock out.

Error	Possible fault
Burner not working	- Thermostat circuit open - Faulty electrical wiring - mains voltage < 187 V
Fan motor/nozzle preheater starts for a short period of time, control box goes to lock out	- Control box has not been reset - Air proving switch not in open position
Control box locks out pre-purge	- Air proving switch has not during closed within 60 secs. - Air proving switch has re-opened
Control box locks out at the end of pre-purge	- Air proving switch open - Flame signal
Burner starts, flame not established, lock out	- Stray light on flame detector (IRD only) - No ignition or no fuel
Burner starts, flame established, after safety time, lock out	- No or too low flame signal (flame does not stick, bad insulation of the ionisation probe, bad connection to frame ground) - Insufficient light on IRD - Sensitivity adjustment too low on IRD

### CIRCUIT AND TIMING DIAGRAM DMG 970

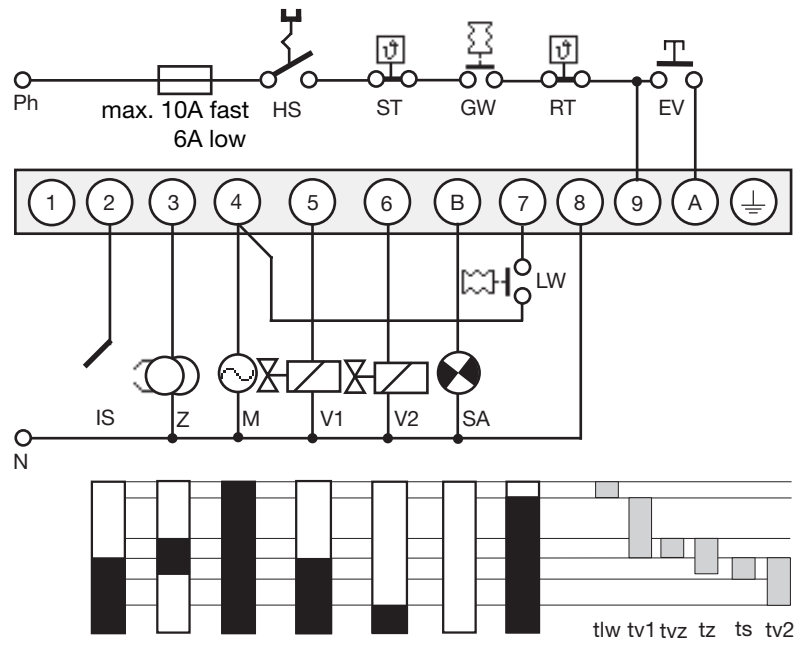

- HS Mains switch
- GW Gas proving switch
- ST Limit thermostat
- RT Control thermostat
- EV External reset and lock out button
- IS Ionisation probe (IRD 1010, UVD 971 see separate diagram)
- Z Ignition
- M Burner motor
- V1 Solenoid valve, 1st-stage
- V2 Solenoid valve, 2nd-stage
- LW Air proving switch
- SA External lock out signal

- tlw max. reaction time for air proving switch
- tv1 Supervised pre-purge time
- tvz Pre-ignition time
- tz Ignition time total
- ts Safety time
- tv2 Delay 2nd-stage

### IRD- OR UVD CONNECTION

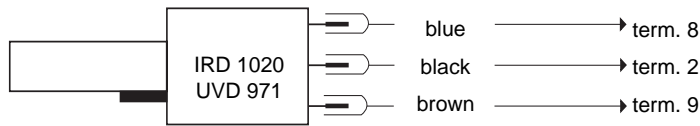

### BLOCK DIAGRAM DMG 970

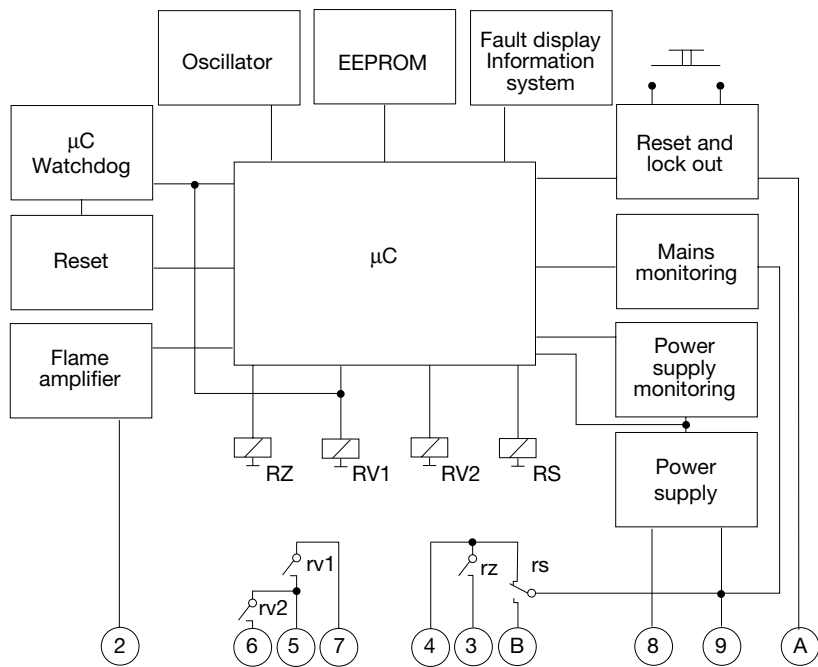

**DMG 970 AND SOCKET**

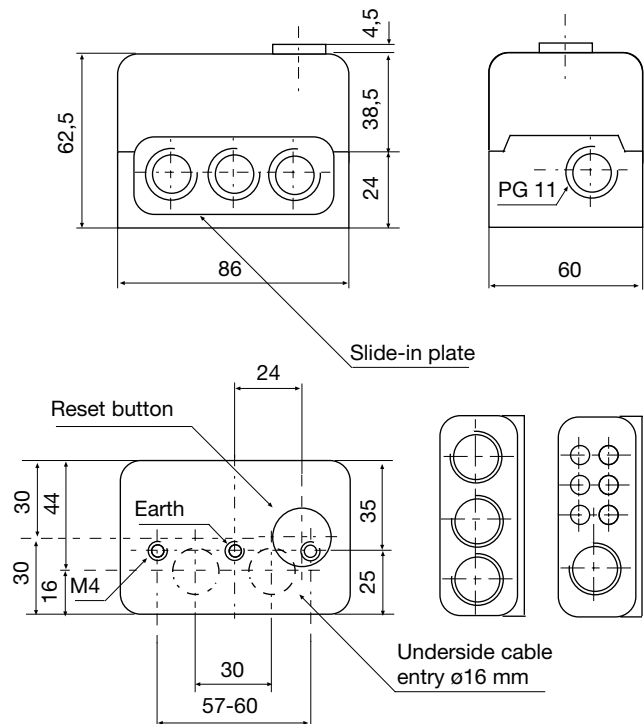

**UVD 971**

**IRD 1020**

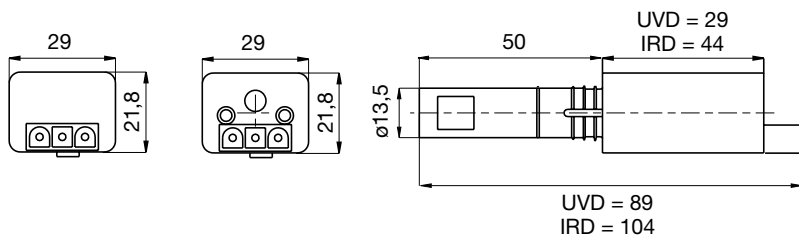

**HOLDER M 93 FOR IRD**

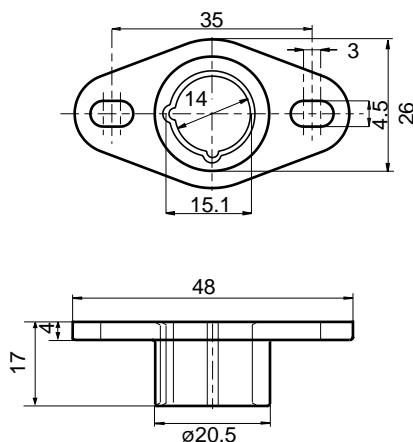

**VARIATION IRD**

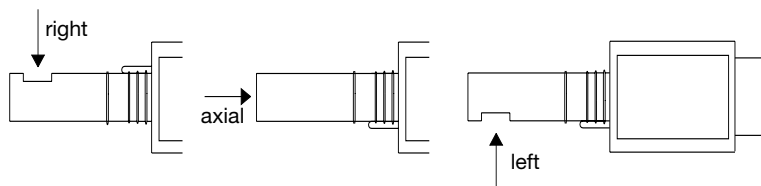

**ORDERING INFORMATION**

ITEM	DESIGNATION	ITEM NO.
Control box	DMG 970 Mod. 01	0350001
Control box	DMG 970 Mod. 02	0350002
Control box	DMG 970 Mod. 03	0350003
Socket	Wiring base S98	75310
Insert plate	PG-Plate	70502
optional	Cable entry plate	70501
Flame detector	IRD 1020 end-on	16522
Flame detector	IRD 1020 left	16523
Flame detector	IRD 1020 right	16521
optional	UVD 971	16722
Support for IRD	Holder M93 for IRD 1020	59093
Support for UVD	Holder M74 for UVD	59074
Connection cable	Plug type, 3 core cable, 0.6 m with tag wire ends	7236001

The above ordering information refers to the standard version.  
Special versions are also included in our product range.

Specifications subject to change without notice

**DMG 970**



Satronic AG  
Brüelstrasse 7  
Postfach 324  
CH-8157 Dielsdorf

## Gas Burner Safety Control

**For 2-stage forced draught and combi oil/gas burners**

**Possible flame detectors:**

- Ionisation probe
- Infrared flicker detector 1020
- UV flame sensor UVD 971

### INTRODUCTION

The burner control box DMG 971 controls and supervises power burner for gas and dual fuel. The control box is approved and certified according the relevant European standards. The use on direct air heaters according DIN 4794 is also possible.

The microprocessor- based programming sequence ensures extremely stable timings independent of voltage variations, ambient temperature and/or switch-on cycles. The built-in information system not only provides a continuous monitoring of the actual state of the box (very helpful especially for monitoring the start-up phase) but also informs about the cause of a possible lock out. The lock out cause is stored in such a way that it can be retrieved even after a power failure.

The control box is designed for maximum safety in case of fluctuations in the voltage supply. If the mains voltage drops below the permitted level, operation is interrupted and the control box automatically prevents the start sequence from being repeated. In this way, the safety of the system is not put at risk by a drop in the mains voltage. This low-voltage protection works not only during start-up but also permanently during operation.

### CONSTRUCTIONAL FEATURES

Microprocessor, electronic components, output relays and flame amplifier are placed on two printed circuit boards. These plus the lockout- and reset circuit are well protected inside a flame resistant, plug-in type plastic housing.

The reset switch for reset / remote lockout with its built-in LED for displaying the information system plus the central fixing screw are placed on top of the housing.

The wiring base S98 is equipped with spare- and extraterminals and allows together with a variety of cable entry points utmost flexibility of electrical wiring.

The DMG 971 is functionally compatible to MMI 811 and MMI 811.1

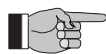

Please note: Is the DMG 971 to be used to replace the MMI 811 or 811.1, care has to be taken to make sure the air proving switch (LW) is wired between terminals 4 and 7 and not like on the MMI between 5 and 7.



### TECHNICAL DATA

Operating voltage	220 / 240 V (-15... +10%)
	50 Hz (±5%)
Fuse rating	10 A fast, 6 A slow
Power consumption	ca. 15 VA
Max. load per output	
- term. 3 ignition trafo	1.5 A, cos φ 0.2
- term. 4 motor	2.0 A, cos φ 0.4
- term. 5 + 6 solenoid valves	1.0 A, cos φ 0.4
- term. B alarm indicator	1.0 A, cos φ 0.4
total load	5.0 A, cos φ 0.4
	max. 10 A during 0.5 sec
Air proving switch	1 working contact 4 A, 230V
Stray light monitoring	5 sec
Sensitivity (operation)	1 μA
Min. required ion. current	1.5 μA
Sensitivity for stray light	0.4 μA
Ionisation probe insulation	Probe - earth
	greater than 50 MΩ
stray capacity	Probe - earth
	less than 1000 pF
cable length	< 3 m
Flame detectors	
IRD 1020	side-on or end-on viewing
UVD 971	end-on viewing
Weight incl. Wiring base	190 g
Mounting position	any
Protection class	IP 40
Approved ambient parameter	
for control and flame detector	max. 95% at 30° C
- for operation	-20° C... +60° C
- for storage	-20° C... +80° C
Build-up of ice, penetration of water and condensing	
water are inadmissible	
Approvals according	
to European standards	EN 298 and EN 230, as well as all other relevant Directives and standards
Classified acc. to EN 298	FLLXN

### Timings (sec.)

Model	waiting time start	max. reaction time for air proving switch tw	supervised pre-purge time tv1	pre-ignition time tvz	ignition time total tz	Stray light monitoring tf	safety time ts	delay 2nd-stage tv2
01	0	60	24	3	5	5	3	12.5

## APPLICATION FEATURES

### 1. Information system

The information system is microprocessor based and reports on all aspects of burner control box operation and flame supervision. It informs continuously about the actual programming sequence the unit is just performing. Besides monitoring of the programming sequence it also allows to identify errors during start-up of operation without any additional testing devices. The automatically performed diagnosis is a valuable tool which facilitates service/maintenance work and therefore saves costs. The analyses of the error cause can be done directly on stage or if not possible afterwards as the lock out reason is stored in a non-volatile lock out mode memory.

The information system communicates with the outside world using a LED (the used Flash-Code is similar to the Morse-Code). The messages are optically transmitted by a appropriately flashing LED. Using an additional terminal (optional), the messages can be recorded and displayed in easy readable form.

#### 1.1 Programming sequence display

The built-in microprocessor controls not only the programming sequence but the information system too. The individual phases of the programming sequence are displayed as Flash-Code.

The following messages can be distinguished:

Message	Flash-Code
waiting for air proving switch	.
pre-purge tv1	.
pre-ignition tvz	.
safety time ts	■   .
delay 2nd stage tv2	■     .
running	_
low mains voltage	■ ■ _

#### Description

| = short pulse

■ = long pulse

. = short pause

\_ = long pause

#### 1.2 Lock-out diagnoses

In case of a failure the LED is permanently illuminated. Every 10 seconds the illumination is interrupted by a flash code, which indicates the cause of the error. Therefore the following sequence is performed which is repeated as long as the unit is not reset.

Sequence:

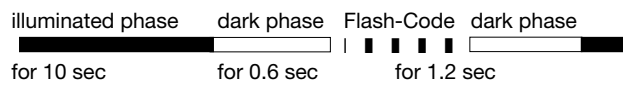

#### Error diagnosis

Error message	Flash-Code	Possible fault
lock out safety time	■ ■ ■ ■	within lock out safety time no flame establishment
stray light	■ ■ ■	stray light during monitored phase, detector may be faulty
air proving switch in closed position	■ ■	air proving switch contact welded
air proving switch time-out	■ ■	air proving switch does not close within specified time
air proving switch opened	■	air proving switch opens during start or operation
loss of flame	■ ■ ■ ■	loss of flame during operation

#### Flash-Code for manual lock out

anual/external | | ■ ■ ■ \_ ■ ■ ■ ■ ■  
 lock out  
 (see also 3. lock out and reset)

## 2. Flame detection

The following types of flame detectors are suitable:

- Ionisation probe, temperature resistant material, well insulated (material and insulation same as for ignition electrode).
  - Infrared-flicker detector type IRD 1020 with mounting flange M 93 or the UV solid state flame sensor UVD 971.
- Flame detection using an ionisation probe is only possible in conjunction with mains supplies which provides a neutral earth connection. Connecting the IRD 1020 or UVD 971 the correct wiring has to be observed.

### 2.1 Stray light monitoring

The stray light check is performed at the end of the pre-purge time for thr duration as mentioned in the technical datas.

### 3. Lock out and reset

The unit can be reset or brought into lock out mode in two different ways:

#### Internal

In the lock out case the unit can be reset by pushing the built-in button meaning a new start-up cycle is performed.

#### External

Instead of using the built-in lock out button the same function can be achieved by using an external button which connects terminal 1 with A (see also circuit and block diagram).

If the pushbutton (internal or external) is pressed during normal operation or during the start sequence for more than 3 sec. and afterwards released, the control box will perform a shutdown.

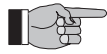

#### Please note

The unit can only be brought to lockout mode or be reset if power is applied to the unit.

### 4. Low-voltage protection

The mains voltage has to be more than  $187 V_{\text{eff}}$  in order to allow the unit to perform a start-up.

The mains voltage is not only monitored in the start-up phase but also permanently during operation. If the voltage drops below  $< 160 V_{\text{eff}}$  during start-up or run time the control box goes into lock out mode. If the voltage rises again, the control box performs automatically a start-up as soon as the mains voltage is  $> 187 V_{\text{eff}}$ .

### 5. Safety

The design and control sequence of the DMG 971 controls will comply with the currently applicable standards and regulations (see also TECHNICAL DATA).

### 6. Mounting and electrical wiring

Wiring base:

- 3 earth terminals with additional terminal for burner earthing
- 3 neutral terminals with internal permanent connection to neutral terminal 8
- 2 independent spare terminals (S1 and S2)
- extra terminals A, B and C are standard
- 2 slide-in plates and 2 easy knock out holes (PG11 thread) plus 2 knock out holes in the base bottom facilitate the base wiring

The digital controls are ideally wired on the new wiring bases S98, which are equipped with (terminals B and C are only for some special types of DMO or DMG) terminal A, which is used for the remote reset / remote lockout functions.

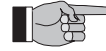

#### Please note

To assist trouble-free operation the main neutral connection terminal in the wiring base must be fully tightened. The terminal screws are already in the undone position. To connect a wire to the terminal, the screw only needs to be fastened.

General: The control box and detector probes should not be subjected to excessive vibration.

## INSTALLATION INSTRUCTIONS AND MAINTENANCE

### 1. Important notes

- The controls must be installed by qualified personnel only. The relevant national regulations have to be observed.
- On commissioning the wiring has to be carefully checked according to the appropriate diagram. Incorrect wiring can damage the unit and endanger the installation.
- The fuse rating has to ensure that the limits specified in TECHNICAL DATA will not be exceeded. If these precautions are not observed, the effect of a short circuit can cause severe damage to the control and installation.
- For safety reasons a minimum of one control shutdown per 24 hours has to be observed.
- Disconnect the mains before the control box is plugged in or out.
- The control box is a safety device and must not be opened!

### 2. Function control

For safety reasons the flame detection system should be tested on commissioning the installation as well as after a service or longer shut-down.

- Start-up with closed gas valve
  - After lock out safety time is over the unit has to go into lock out mode!
- Normal start-up, when burner is running, close gas valve
  - After loss of flame, the control box has to go into lockout mode
- Normal start-up, during pre-purge or operation, interrupt the air proving switch
  - The control box has to perform a lockout immediately
- Bridged air proving switch before start
  - the fan motor switches on for approx. 2 - 3 secs, followed by a lockout. After 10 secs., this quick lockout is reset by the control box and a second start attempt follows (fan motor switches on for approx. 2 - 3 secs.). A standard lockout appears if the air proving switch (LW) contact is still in its closed position (e.g. welded contacts). Has the air proving switch (LW) changed to its open position in the meantime (e.g. by a run down motor), a normal start sequence follows.

### 3. Fault finding

The built-in information system facilitates the trouble shooting in the case of problems occurring during start-up or during operation.

A list of possible lock out messages can be found in APPLICATION FEATURES chapter 1.2.

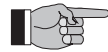

#### Please note:

**The control box is locked in lock out mode and the reason for the lock out is displayed until the control box is reset, either by an internal or external reset (see also subject "3. Lock out and reset").**

Removing the control box from its wiring base or by interrupting the supply line may not reset a lock out. Therefore, by applying power, the fan motor switches on for 2-3 secs. before the control box goes to lock out again and the cause of the last lock out.

Error	Possible fault
Burner not working	- Thermostat circuit open - Faulty electrical wiring - mains voltage < 187 V
Fan motor/nozzle preheater starts for a short period of time, control box goes to lock out	- Control box has not been reset - Air proving switch not in open position
Control box locks out pre-purge	- Air proving switch has not during closed within 60 secs. - Air proving switch has re-opened
Control box locks out at the end of pre-purge	- Air proving switch open - Flame signal
Burner starts, flame not established, lock out	- Stray light on flame detector (IRD only) - No ignition or no fuel
Burner starts, flame established, after safety time, lock out	- No or too low flame signal (flame does not stick, bad insulation of the ionisation probe, bad connection to frame ground) - Insufficient light on IRD - Sensitivity adjustment too low on IRD

### CIRCUIT AND TIMING DIAGRAM DMG 971

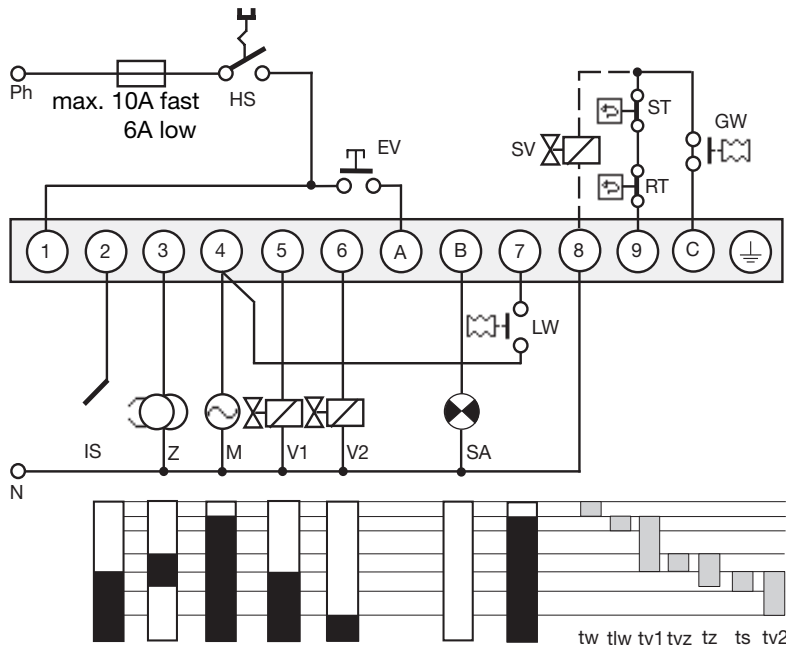

- HS Mains switch
- GW Gas proving switch
- ST Limit thermostat
- RT Control thermostat
- EV External reset and lock out button
- IS Ionisation probe  
(IRD 1010, UVD 971 see separate diagram)
- Z Ignition
- M Burner motor
- V1 Solenoid valve, 1st-stage
- V2 Solenoid valve, 2nd-stage
- LW Air proving switch
- SA External lock out signal
  
- tw max. reaction time for air proving switch
- tv1 Supervised pre-purge time
- tvz Pre-ignition time
- tz Ignition time total
- ts Safety time
- tv2 Delay 2nd-stage

### IRD- OR UVD CONNECTION

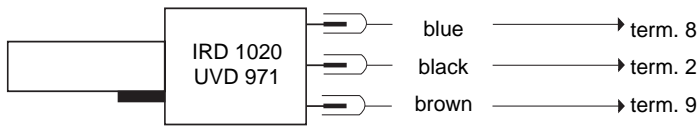

### BLOCK DIAGRAM DMG 971

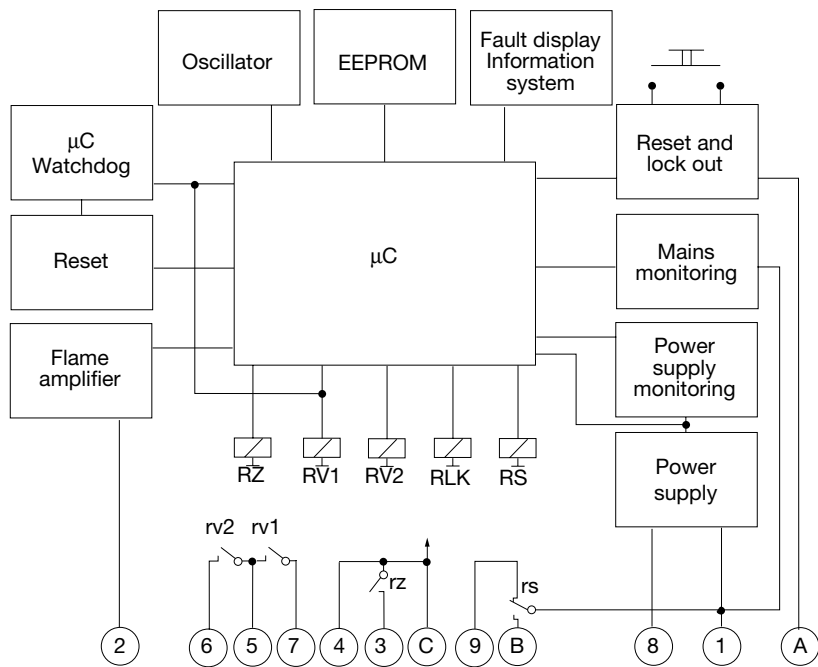

**DMG 971 AND SOCKET**

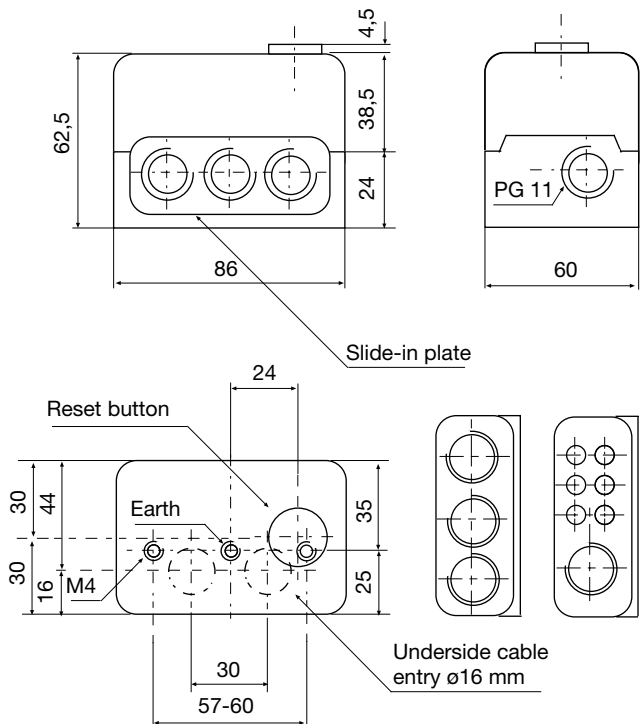

**UVD 971**

**IRD 1020**

**HOLDER M 93 FOR IRD**

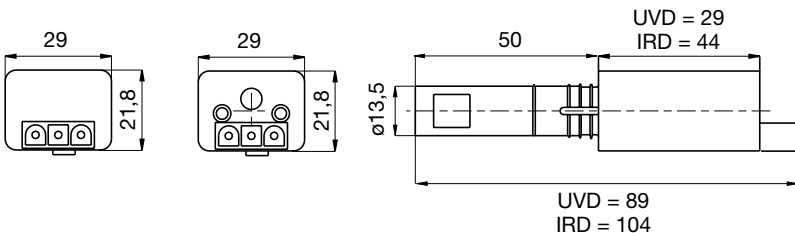

**VARIATION IRD**

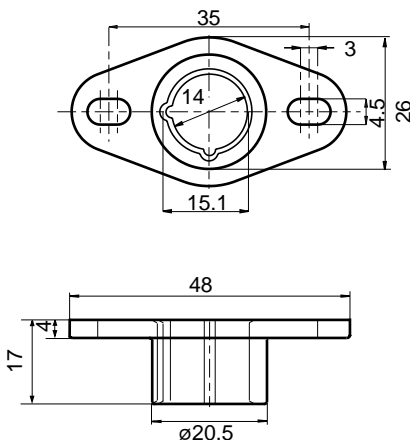
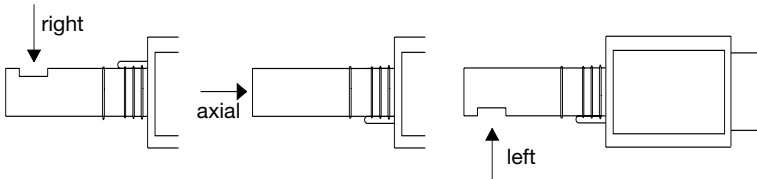

**ORDERING INFORMATION**

ITEM	DESIGNATION	ITEM NO.
Control box	DMG 971 Mod. 01	0351001
Socket	Wiring base S98	75310
Insert plate	PG-Plate	70502
optional	Cable entry plate	70501
Flame detector	IRD 1020 end-on	16522
Flame detector	IRD 1020 left	16523
Flame detector	IRD 1020 right	16521
optional	UVD 971	16722
Support for IRD	Holder M93 for IRD 1020	59093
Support for UVD	Holder M74 for UVD	59074
Connection cable	Plug type, 3 core cable, 0.6 m with tag wire ends	7236001

The above ordering information refers to the standard version.  
Special versions are also included in our product range.

Specifications subject to change without notice

**DMG 971**



Satronic AG  
Brüelstrasse 7  
Postfach 324  
CH-8157 Dielsdorf

## Gas Burner Safety Control

**For 2-stage forced draught and combi oil/gas burners, facility to connect an air damper unit**

**Possible flame detectors:**

- Ionisation probe
- Infrared flicker detector 1020
- UV flame sensor UVD 971

### INTRODUCTION

The burner control box DMG 972 controls and supervises power burner for gas and dual fuel. The control box is approved and certified according the relevant European standards. The use on direct air heaters according DIN 4794 is also possible.

With the facility to connect an air damper unit, a 2 stage operation with two fuel valves or a modulating operation with one fuel valve is possible.

The microprocessor- based programming sequence ensures extremely stable timings independent of voltage variations, ambient temperature and/or switch-on cycles. The built-in information system not only provides a continuous monitoring of the actual state of the box (very helpful especially for monitoring the start-up phase) but also informs about the cause of a possible lock out. The lock out cause is stored in such a way that it can be retrieved even after a power failure.

The control box is designed for maximum safety in case of fluctuations in the voltage supply. If the mains voltage drops below the permitted level, operation is interrupted and the control box automatically prevents the start sequence from being repeated. In this way, the safety of the system is not put at risk by a drop in the mains voltage. This low-voltage protection works not only during start-up but also permanently during operation.

### CONSTRUCTIONAL FEATURES

Microprocessor, electronic components, output relays and flame amplifier are placed on two printed circuit boards. These plus the lockout- and reset circuit are well protected inside a flame resistant, plug-in type plastic housing.

The reset switch for reset / remote lockout with its built-in LED for displaying the information system plus the central fixing screw are placed on top of the housing.

The wiring base S98 is equipped with spare- and extraterminals and allows together with a variety of cable entry points utmost flexibility of electrical wiring.

The DMG 972 is functionally compatible to MMI 812, MMI 812.1, MMI 962 and MMI 962.1



Is the DMG972 to be used to replace the MMI 812, 812.1, MMI 962 or MMI 962.1 care has to be taken to make sure the air proving switch (LW) is wired between terminals 4 and 7 and not like on the MMI between 5 and 7.



### TECHNICAL DATA

Operating voltage	220 / 240 V (-15... +10%) 50 Hz (±5%)
Fuse rating	10 A fast, 6 A slow
Power consumption	ca. 15 VA
Max. load per output	
- term. 3 ignition trafo	1.5 A, cos φ 0.2
- term. 4 motor	2.0 A, cos φ 0.4
- term. 5 + 6 solenoid valves	1.0 A, cos φ 0.4
- term. C air damper	1.0 A, cos φ 0.4
- term. B alarm indicator	1.0 A, cos φ 0.4
total load	5.0 A, cos φ 0.4 max. 10 A during 0.5 sec 1 working contact 4 A, 230V
Air proving switch	
Sensitivity (operation)	1 µA
Min. required ion. current	1.5 µA
Sensitivity for stray light	0.4µA
Ionisation probe insulation	Probe - earth greater than 50 MΩ
stray capacity	Probe - earth less than 1000 pF
cable lenght	< 3 m
Flame detectors	
IRD 1020	side-on or end-on viewing
UVD 971	end-on viewing
Weight incl. Wiring base	190 g
Mounting position	any
Protection class	IP 40
Approved ambient parameter	
for control and flame detector	max. 95% at 30° C
- for operation	-20° C... +60° C
- for storage	-20° C... +80° C
Build-up of ice, penetration of water and condensing	water are inadmissible
Approvals according	
to European standards	EN 298 and EN 230, as well as all other relevant Directives and standards FTLLXN
Classified acc. to EN 298	

### Timings (sec.)

Model	waiting time start	max. reaction time for air proving switch <b>tlw</b>	supervised pre-purge time <b>tv1</b>	pre-ignition time <b>tvz</b>	LK-open command during pre-purge <b>tkl</b>	LK-close movement <b>tr</b>	ignition time total <b>tz</b>	Stray light monitoring <b>tf</b>	safety time <b>ts</b>	delay terminal 6 <b>tv2</b>
<b>01</b>	0	60	44	3	36	8	5.5	5	3	6

## APPLICATION FEATURES

### 1. Information system

The information system is microprocessor based and reports on all aspects of burner control box operation and flame supervision. It informs continuously about the actual programming sequence the unit is just performing. Besides monitoring of the programming sequence it also allows to identify errors during start-up of operation without any additional testing devices. The automatically performed diagnosis is a valuable tool which facilitates service/maintenance work and therefore saves costs. The analyses of the error cause can be done directly on stage or if not possible afterwards as the lock out reason is stored in a non-volatile lock out mode memory.

The information system communicates with the outside world using a LED (the used Flash-Code is similar to the Morse-Code). The messages are optically transmitted by a appropriately flashing LED. Using an additional terminal (optional), the messages can be recorded and displayed in easy readable form.

#### 1.1 Programming sequence display

The built-in microprocessor controls not only the programming sequence but the information system too. The individual phases of the programming sequence are displayed as Flash-Code.

The following messages can be distinguished:

Message	Flash-Code
waiting for air proving switch	.
pre-purge tv1	.
pre-ignition tvz	.
safety time ts	■   .
delay 2nd stage tv2	■     .
running	_
low mains voltage	■ ■ _

#### Description

- | = short pulse
- = long pulse
- . = short pause
- \_ = long pause

### 1.2 Lock-out diagnoses

In case of a failure the LED is permanently illuminated. Every 10 seconds the illumination is interrupted by a flash code, which indicates the cause of the error. Therefore the following sequence is performed which is repeated as long as the unit is not reset.

Sequence:

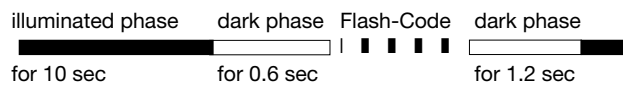

#### Error diagnosis

Error message	Flash-Code	Possible fault
lock out safety time	■ ■ ■ ■	within lock out safety time no flame establishment
stray light	■ ■ ■	stray light during monitored phase, detector may be faulty
air proving switch in closed position	■ ■	air proving switch contact welded
air proving switch time-out	■ ■	air proving switch does not close within specified time
air proving switch opened	■	air proving switch opens during start or operation
loss of flame	■ ■ ■ ■	loss of flame during operation

#### Flash-Code for manual lock out

anual/external lock out	■ ■ ■ _ ■ ■ ■ ■ ■
(see also 3. lock out and reset)	

## 2. Flame detection

The following types of flame detectors are suitable:

- Ionisation probe, temperature resistant material, well insulated (material and insulation same as for ignition electrode).
  - Infrared-flicker detector type IRD 1020 with mounting flange M 93 or the UV solid state flame sensor UVD 971.
- Flame detection using an ionisation probe is only possible in conjunction with mains supplies which provides a neutral earth connection. Connecting the IRD 1020 or UVD 971 the correct wiring has to be observed.

### 2.1 Stray light monitoring

The stray light check is performed at the end of the pre-purge time for thr duration as mentioned in the technical datas.

### 3. Lock out and reset

The unit can be reset or brought into lock out mode in two different ways:

#### Internal

In the lock out case the unit can be reset by pushing the built-in button meaning a new start-up cycle is performed.

#### External

Instead of using the built-in lock out button the same function can be achieved by using an external button which connects terminal 9 with A (see also circuit and block diagram).

If the pushbutton (internal or external) is pressed during normal operation or during the start sequence for more than 3 sec. and afterwards released, the control box will perform a shutdown.



#### Please note

The unit can only be brought to lockout mode or be reseted if power is applied to the unit.

### 4. Low-voltage protection

The mains voltage has to be more than  $187 V_{eff}$  in order to allow the unit to perform a start-up.

The mains voltage is not only monitored in the start-up phase but also permanently during operation. If the voltage drops below  $< 160 V_{eff}$  during start-up or run time the control box goes into lock out mode. If the voltage rises again, the control box performs automatically a start-up as soon as the mains voltage is  $> 187 V_{eff}$ .

### 5. Safety

The design and control sequence of the DMG 972 controls will comply with the currently applicable standards and regulations (see also TECHNICAL DATA).

### 6. Burner with an air damper motor

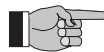

The position of the air damper during pre-purge has to be assured by suitable actions (EN 676, 4.4.1.2).

### 7. Mounting and electrical wiring

Wiring base:

- 3 earth terminals with additional terminal for burner earthing
- 3 neutral terminals with internal permanent connection to neutral terminal 8
- 2 independant spare terminals (S1 and S2)
- extra terminals A, B and C are standard
- 2 slide-in plates and 2 easy knock out holes (PG11 thread) plus 2 knock out holes in the base bottom facilitate the base wiring

The digital controls are ideally wired on the new wiring bases S98, which are equipped with (terminals B and C are only for some special types of DMO or DMG) terminal A, which is used for the remote reset / remote lockout functions.

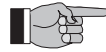

#### Please note

To assist trouble-free operation the main neutral connection terminal in the wiring base must be fully tightened. The terminal screws are already in the undone position. To connect a wire to the terminal, the screw only needs to be fastened.

General: The control box and detector probes should not be subjected to excessive vibration.

## INSTALLATION INSTRUCTIONS AND MAINTENANCE

### 1. Important notes

- The controls must be installed by qualified personnel only. The relevant national regulations have to be observed.
- On commissioning the wiring has to be carefully checked according the appropriate diagram, Incorrect wiring can damage the unit and endanger the installation.
- The fuse rating has to ensure that the limits specified in TECHNICAL DATA will not be exceeded. If these precautions are not observed, the effect of a short circuit can cause severe damage to the control and installation.
- For safety reasons a minimum of one control shutdown per 24 hours has to be observed.
- Disconnect the mains before the control box is plugged in or out.
- The control box is a safety device and must not be opened!

### 2. Function control

For safety reasons the flame detection system should be tested on commissioning the installation as well as after a service or longer shut-down.

- Start-up with closed gas valve
  - After lock out safety time is over the unit has to go into lock out mode!
- Normal start-up, when burner is running, close gas valve
  - After loss of flame, the control box has to go into lockout mode
- Normal start-up, during pre-purge or operation, interrupt the air proving switch
  - The control box has to perform a lockout immediatly
- Bridged air proving switch before start
  - the fan motor switches on for approx. 2 - 3 secs, followed by a lockout. After 10 secs., this quick lockout is resetted by the control box and a second start attempt follows (fan motor switches on for approx. 2 - 3 secs.). A standard lockout appears if the air proving switch (LW) contact is still in it's closed position (e.g. welded contacts). Has the air proving switch (LW) changed to it's open position in the meantime (e.g. by a run down motor), a normal start sequence follows.

### 3. Fault finding

The built-in information system facilitates the trouble shooting in the case of problems occurring during start-up or during operation.

A list of possible lock out messages can be found in APPLICATION FEATURES chapter 1.2.

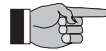

#### Please note:

**The control box is locked in lock out mode and the reason for the lock out is displayed until the control box is reset, either by an internal or external reset (see also subject "3. Lock out and reset").**

Removing the control box from its wiring base or by interrupting the supply line may **not** reset a lock out. Therefore, by applying power, the fan motor switches on for 2-3 secs. before the control box goes to lock out again and the cause of the last lock out.

Error	Possible fault
Burner not working	- Thermostat circuit open - Faulty electrical wiring - mains voltage < 187 V
Fan motor/nozzle preheater starts for a short period of time, control box goes to lock out	- Control box has not been reset - Air proving switch not in open position
Control box locks out during pre-purge	- Air proving switch open
Control box locks out at the end of pre-purge	- Air proving switch open - Flame signal
Burner starts, flame not established, lock out	- No ignition or no fuel
Burner starts, flame established, after safety time, lock out	- No or too low flame signal (flame does not stick, bad insulation of the ionisation probe, bad connection to frame ground) - Insufficient light on IRD - Sensitivity adjustment too low on IRD

**CIRCUIT AND TIMING DIAGRAM DMG 972  
WITH AIR DAMPER MOTOR**

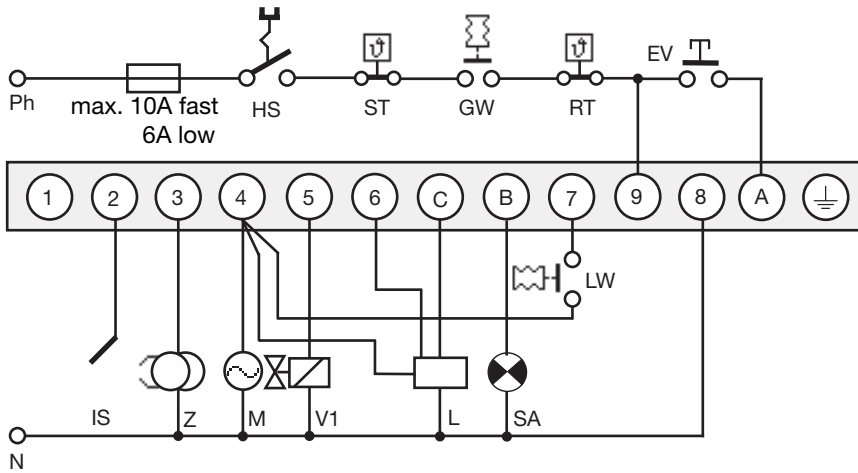

HS Mains switch  
 GW Gas proving switch  
 ST Limit thermostat  
 RT Control thermostat  
 EV External reset and lock out button  
 IS Ionisation probe  
 (IRD 1010, UVD 970 see separate diagram)

Z Ignition  
 M Burner motor  
 V1 Solenoid valve, 1st-stage  
 V2 Solenoid valve, 2nd-stage  
 LW Air proving switch  
 SA External lock out signal  
 L Air damper motor

tlw max. reaction time for air proving switch

tv1 Supervised pre-purge time

tlk LK-open command during pre-purge

tr LK-close movement

tvz Pre-ignition time

tz Ignition time total

ts Safety time

tv2 Delay terminal 6

**WITHOUT AIR DAMPER MOTOR**

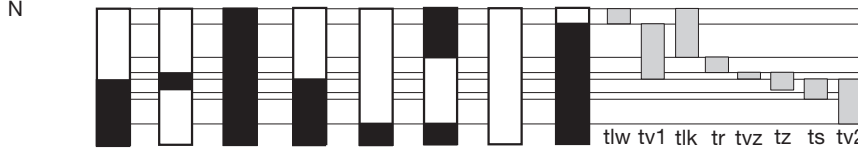
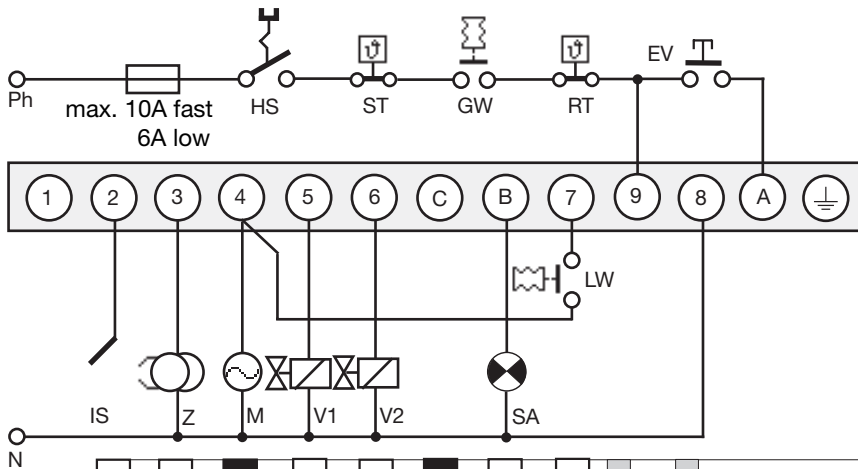

**IRD- OR UVD CONNECTION**

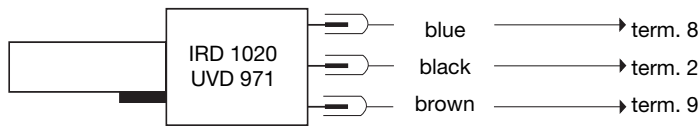

**BLOCK DIAGRAM DMG 972**

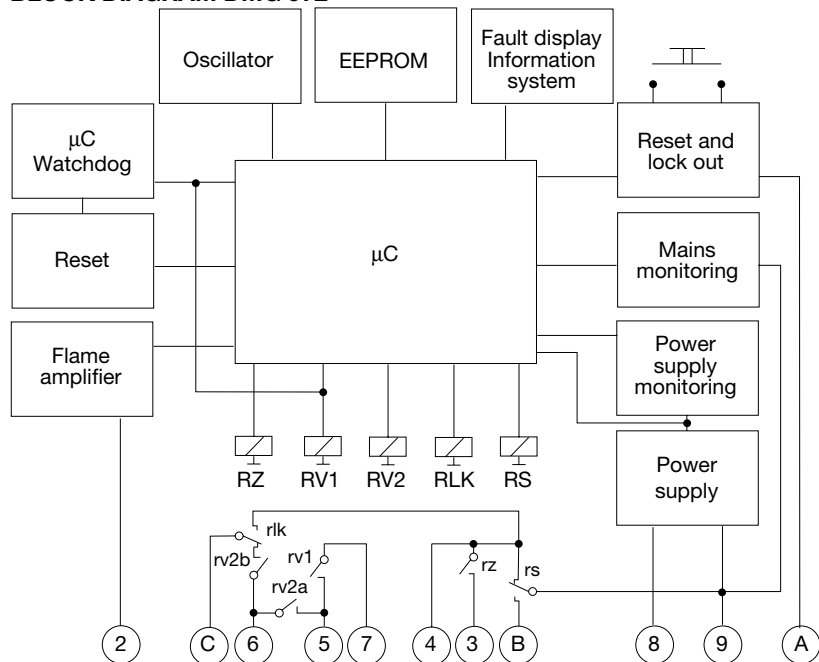

DMG 972

## DMG 972 AND SOCKET

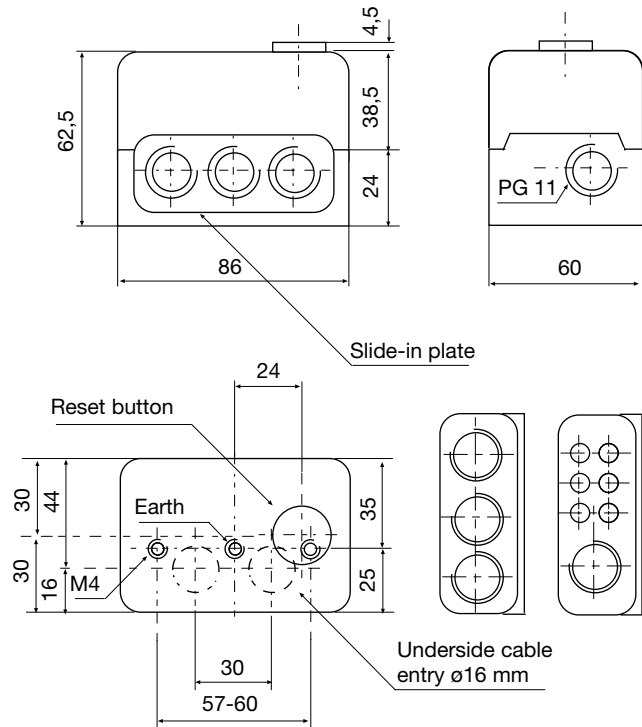

## UVD 971

## IRD 1020

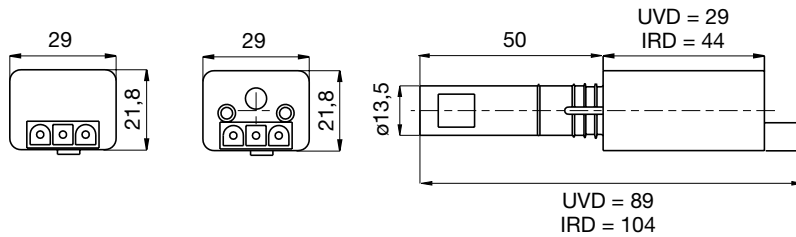

## HOLDER M 93 FOR IRD

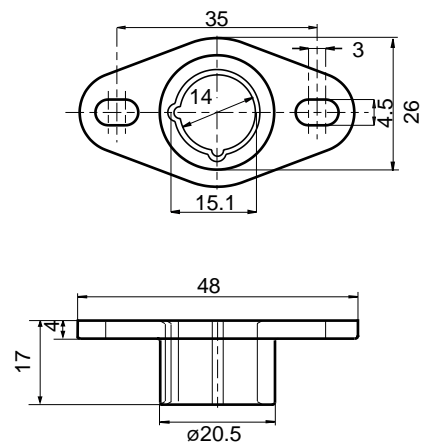

## VARIATION IRD

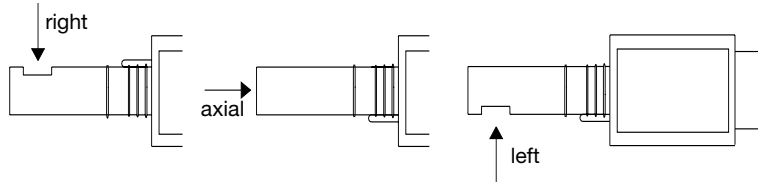

## ORDERING INFORMATION

ITEM	DESIGNATION	ITEM NO.
Control box	DMG 972 Mod. 01	032001
Socket	Wiring base S98	75310
Insert plate	PG-Plate	70502
optional	Cable entry plate	70501
Flame detector	IRD 1020 end-on	16522
Flame detector	IRD 1020 left	16523
Flame detector	IRD 1020 right	16521
optional	UVD 971	16722
Support for IRD	Holder M93 for IRD 1020	59093
Support for UVD	Holder M74 for UVD	59074
Connection cable	Plug type, 3 core cable, 0.6 m with tag wire ends	7236001

The above ordering information refers to the standard version.  
Special versions are also included in our product range.

Specifications subject to change without notice

## DMG 972



A Honeywell Company

Satronic AG  
Brüelstrasse 7  
Postfach 324  
CH-8157 Dielsdorf

## Gas Burner Safety Control

**For 2-stage forced draught and combi oil/gas burners, facility to connect an air damper unit**

**Possible flame detectors:**

- Ionisation probe
- Infrared flicker detector 1020
- UV flame sensor UVD 971

### INTRODUCTION

The burner control box DMG 973 controls and supervises power burner for gas and dual fuel. The control box is currently under approval according the relevant European standards. The use on direct air heaters according DIN 4794 is also possible.

With the facility to connect an air damper unit, a 2 stage operation with two fuel valves or a modulating operation with one fuel valve is possible.

The microprocessor- based programming sequence ensures extremely stable timings independent of voltage variations, ambient temperature and/or switch-on cycles. The built-in information system not only provides a continuous monitoring of the actual state of the box (very helpful especially for monitoring the start-up phase) but also informs about the cause of a possible lock out. The lock out cause is stored in such a way that it can be retrieved even after a power failure.

The control box is designed for maximum safety in case of fluctuations in the voltage supply. If the mains voltage drops below the permitted level, operation is interrupted and the control box automatically prevents the start sequence from being repeated. In this way, the safety of the system is not put at risk by a drop in the mains voltage. This low-voltage protection works not only during start-up but also permanently during operation.

### CONSTRUCTIONAL FEATURES

Microprocessor, electronic components, output relays and flame amplifier are placed on two printed circuit boards. These plus the lockout- and reset circuit are well protected inside a flame resistant, plug-in type plastic housing.

The reset switch for reset / remote lockout with its built-in LED for displaying the information system plus the central fixing screw are placed on top of the housing.

The wiring base S98 is equipped with spare- and extraterminals and allows together with a variety of cable entry points utmost flexibility of electrical wiring.

The DMG 973 is functionally compatible to MMI 813 and MMI 813.1

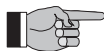

Please note: Is the DMG 973 to be used to replace the MMI 813 or 813.1, care has to be taken to make sure the air proving switch (LW) is wired between terminals 4 and 7 and not like on the MMI between 5 and 7.



### TECHNICAL DATA

Operating voltage	220 / 240 V (-15... +10%) 50 Hz (±5%)
Fuse rating	10 A fast, 6 A slow
Power consumption	ca. 15 VA
Max. load per output	
- term. 3 ignition trafo	1.5 A, cos φ 0.2
- term. 4 motor	2.0 A, cos φ 0.4
- term. 5 + 6 solenoid valves	1.0 A, cos φ 0.4
- term. C air damper	1.0 A, cos φ 0.4
- term. B alarm indicator	1.0 A, cos φ 0.4
total load	5.0 A, cos φ 0.4 max. 10 A during 0.5 sec 1 working contact 4 A, 230V
Air proving switch	
Sensitivity (operation)	1 µA
Min. required ion. current	1.5 µA
Sensitivity for stray light	0.4µA
Ionisation probe insulation	Probe - earth greater than 50 MΩ
stray capacity	Probe - earth less than 1000 pF
cable lenght	< 3 m
Flame detectors	
IRD 1020	side-on or end-on viewing
UVD 971	end-on viewing
Weight incl. Wiring base	190 g
Mounting position	any
Protection class	IP 40
Approved ambient parameter	
for control and flame detector	max. 95% at 30° C
- for operation	-20° C... +60° C
- for storage	-20° C... +80° C
Build-up of ice, penetration of water and condensing water are inadmissible	
Approvals according to European standards	EN 298 and EN 230, as well as all other relevant Directives and standards FTLLXN
Classified acc. to EN 298	

### Timings (sec.)

Model	waiting time start	max. reaction time for air proving switch <b>tlw</b>	supervised pre-purge time <b>tv1</b>	pre-ignition time <b>tvz</b>	LK-open command during pre-purge <b>tkl</b>	LK-close movement <b>tr</b>	ignition time total <b>tz</b>	Stray light monitoring <b>tf</b>	safety time <b>ts</b>	delay terminal 6 <b>tv2</b>
<b>01</b>	0	60	44	3	36	8	5.5	5	3	6

## APPLICATION FEATURES

### 1. Information system

The information system is microprocessor based and reports on all aspects of burner control box operation and flame supervision. It informs continuously about the actual programming sequence the unit is just performing. Besides monitoring of the programming sequence it also allows to identify errors during start-up of operation without any additional testing devices. The automatically performed diagnosis is a valuable tool which facilitates service/maintenance work and therefore saves costs. The analyses of the error cause can be done directly on stage or if not possible afterwards as the lock out reason is stored in a non-volatile lock out mode memory.

The information system communicates with the outside world using a LED (the used Flash-Code is similar to the Morse-Code). The messages are optically transmitted by a appropriately flashing LED. Using an additional terminal (optional), the messages can be recorded and displayed in easy readable form.

#### 1.1 Programming sequence display

The built-in microprocessor controls not only the programming sequence but the information system too. The individual phases of the programming sequence are displayed as Flash-Code.

The following messages can be distinguished:

Message	Flash-Code
waiting for air proving switch	.
pre-purge tv1	.
pre-ignition tvz	.
safety time ts	■   .
delay 2nd stage tv2	■     .
running	_
low mains voltage	■ ■ _

#### Description

- | = short pulse
- = long pulse
- . = short pause
- \_ = long pause

### 1.2 Lock-out diagnoses

In case of a failure the LED is permanently illuminated. Every 10 seconds the illumination is interrupted by a flash code, which indicates the cause of the error. Therefore the following sequence is performed which is repeated as long as the unit is not reset.

Sequence:

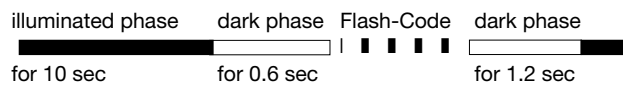

#### Error diagnosis

Error message	Flash-Code	Possible fault
lock out safety time	■ ■ ■ ■	within lock out safety time no flame establishment
stray light	■ ■ ■	stray light during monitored phase, detector may be faulty
air proving switch in closed position	■ ■	air proving switch contact welded
air proving switch time-out	■ ■	air proving switch does not close within specified time
air proving switch opened	■	air proving switch opens during start or operation
loss of flame	■ ■ ■ ■	loss of flame during operation

#### Flash-Code for manual lock out

anual/external lock out	■ ■ ■ _ ■ ■ ■ ■ ■
(see also 3. lock out and reset)	

## 2. Flame detection

The following types of flame detectors are suitable:

- Ionisation probe, temperature resistant material, well insulated (material and insulation same as for ignition electrode).
  - Infrared-flicker detector type IRD 1020 with mounting flange M 93 or the UV solid state flame sensor UVD 971.
- Flame detection using an ionisation probe is only possible in conjunction with mains supplies which provides a neutral earth connection. Connecting the IRD 1020 or UVD 971 the correct wiring has to be observed.

### 2.1 Stray light monitoring

The stray light check is performed at the end of the pre-purge time for thr duration as mentioned in the technical datas.

### 3. Lock out and reset

The unit can be reset or brought into lock out mode in two different ways:

#### Internal

In the lock out case the unit can be reset by pushing the built-in button meaning a new start-up cycle is performed.

#### External

Instead of using the built-in lock out button the same function can be achieved by using an external button which connects terminal 9 with A (see also circuit and block diagram).

If the pushbutton (internal or external) is pressed during normal operation or during the start sequence for more than 3 sec. and afterwards released, the control box will perform a shutdown.

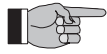

#### Please note

The unit can only be brought to lockout mode or be reset if power is applied to the unit.

### 4. Low-voltage protection

The mains voltage has to be more than  $187 V_{\text{eff}}$  in order to allow the unit to perform a start-up.

The mains voltage is not only monitored in the start-up phase but also permanently during operation. If the voltage drops below  $< 160 V_{\text{eff}}$  during start-up or run time the control box goes into lock out mode. If the voltage rises again, the control box performs automatically a start-up as soon as the mains voltage is  $> 187 V_{\text{eff}}$ .

### 5. Safety

The design and control sequence of the DMG 970 controls will comply with the currently applicable standards and regulations (see also TECHNICAL DATA).

### 6. Burner with an air damper motor



The position of the air damper during pre-purge has to be assured by suitable actions (EN 676, 4.4.1.2).

### 7. Mounting and electrical wiring

Wiring base:

- 3 earth terminals with additional terminal for burner earthing
- 3 neutral terminals with internal permanent connection to neutral terminal 8
- 2 independant spare terminals (S1 and S2)
- extra terminals A, B and C are standard
- 2 slide-in plates and 2 easy knock out holes (PG11 thread) plus 2 knock out holes in the base bottom facilitate the base wiring

The digital controls are ideally wired on the new wiring bases S98, which are equipped with (terminals B and C are only for some special types of DMO or DMG) terminal A, which is used for the remote reset / remote lockout functions.

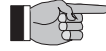

#### Please note

To assist trouble-free operation the main neutral connection terminal in the wiring base must be fully tightened. The terminal screws are already in the undone position. To connect a wire to the terminal, the screw only needs to be fastened.

General: The control box and detector probes should not be subjected to excessive vibration.

## INSTALLATION INSTRUCTIONS AND MAINTENANCE

### 1. Important notes

- The controls must be installed by qualified personnel only. The relevant national regulations have to be observed.
- On commissioning the wiring has to be carefully checked according to the appropriate diagram, incorrect wiring can damage the unit and endanger the installation.
- The fuse rating has to ensure that the limits specified in TECHNICAL DATA will not be exceeded. If these precautions are not observed, the effect of a short circuit can cause severe damage to the control and installation.
- For safety reasons a minimum of one control shutdown per 24 hours has to be observed.
- Disconnect the mains before the control box is plugged in or out.
- The control box is a safety device and must not be opened!

### 2. Function control

For safety reasons the flame detection system should be tested on commissioning the installation as well as after a service or longer shut-down.

- Start-up with closed gas valve
  - After lock out safety time is over the unit has to go into lock out mode!
- Normal start-up, when burner is running, close gas valve
  - After loss of flame, the control box has to go into lockout mode
- Normal start-up, during pre-purge or operation, interrupt the air proving switch
  - The control box has to perform a lockout immediately
- Bridged air proving switch before start
  - the fan motor switches on for approx. 2 - 3 secs, followed by a lockout. After 10 secs., this quick lockout is reset by the control box and a second start attempt follows (fan motor switches on for approx. 2 - 3 secs.). A standard lockout appears if the air proving switch (LW) contact is still in its closed position (e.g. welded contacts). Has the air proving switch (LW) changed to its open position in the meantime (e.g. by a run down motor), a normal start sequence follows.

### 3. Fault finding

The built-in information system facilitates the trouble shooting in the case of problems occurring during start-up or during operation.

A list of possible lock out messages can be found in APPLICATION FEATURES chapter 1.2.

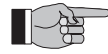

#### Please note:

**The control box is locked in lock out mode and the reason for the lock out is displayed until the control box is reset, either by an internal or external reset (see also subject "3. Lock out and reset").**

Removing the control box from its wiring base or by interrupting the supply line may **not** reset a lock out. Therefore, by applying power, the fan motor switches on for 2-3 secs. before the control box goes to lock out again and the cause of the last lock out.

Error	Possible fault
Burner not working	- Thermostat circuit open - Faulty electrical wiring - mains voltage < 187 V
Fan motor/nozzle preheater starts for a short period of time, control box goes to lock out	- Control box has not been reset - Air proving switch not in open position
Control box locks out during pre-purge	- Air proving switch open
Control box locks out at the end of pre-purge	- Air proving switch open - Flame signal
Burner starts, flame not established, lock out	- No ignition or no fuel
Burner starts, flame established, after safety time, lock out	- No or too low flame signal (flame does not stick, bad insulation of the ionisation probe, bad connection to frame ground) - Insufficient light on IRD - Sensitivity adjustment too low on IRD

**CIRCUIT AND TIMING DIAGRAM DMG 973  
WITH AIR DAMPER MOTOR**

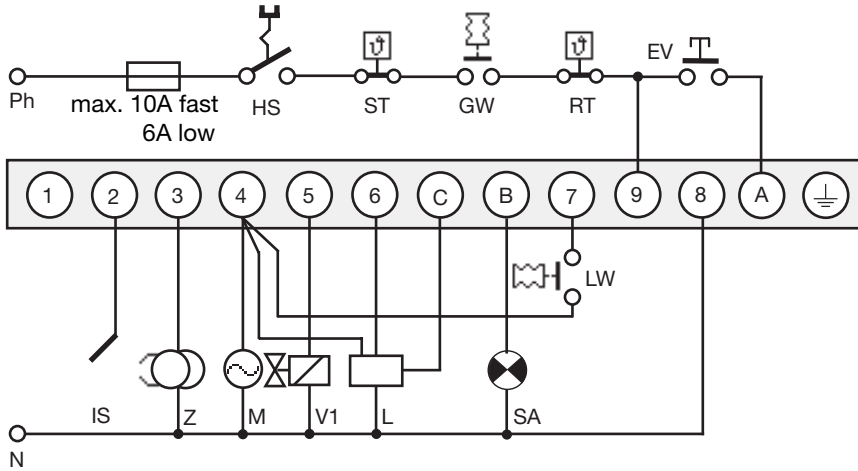

HS Mains switch  
 GW Gas proving switch  
 ST Limit thermostat  
 RT Control thermostat  
 EV External reset and lock out button  
 IS Ionisation probe  
 (IRD 1010, UVD 970 see separate diagram)

Z Ignition  
 M Burner motor  
 V1 Solenoid valve, 1st-stage  
 V2 Solenoid valve, 2nd-stage  
 LW Air proving switch  
 SA External lock out signal  
 L Air damper motor

tlw max. reaction time for air proving switch

tv1 Supervised pre-purge time

tlk LK-open command during pre-purge

tr LK-close movement

tvz Pre-ignition time

tz Ignition time total

ts Safety time

tv2 Delay terminal 6

**WITHOUT AIR DAMPER MOTOR**

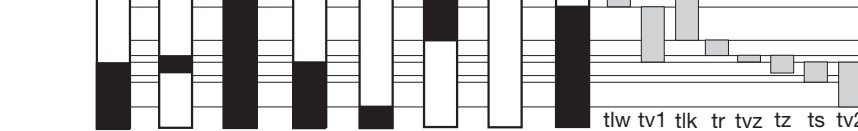
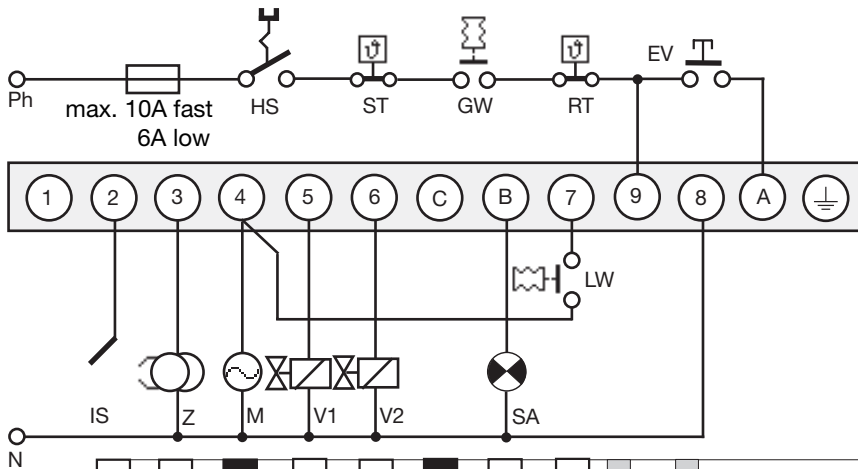

**IRD- OR UVD CONNECTION**

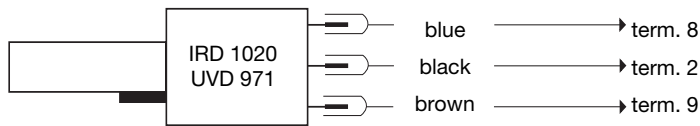

**BLOCK DIAGRAM DMG 973**

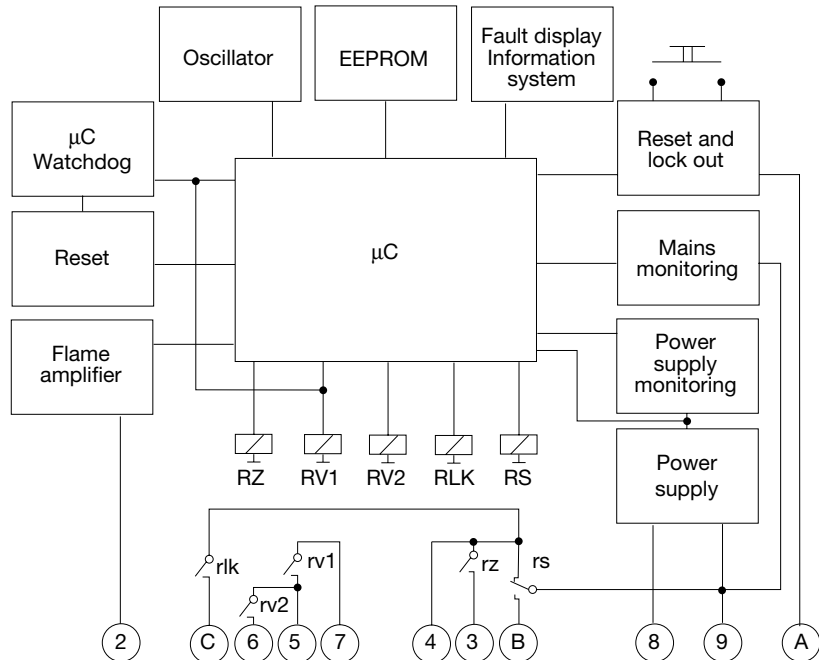

## DMG 973 AND SOCKET

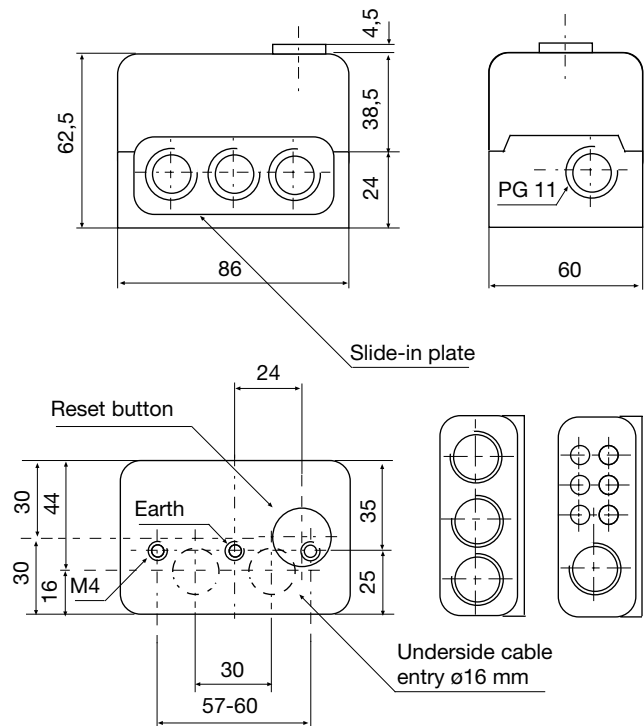

## UVD 971

## IRD 1020

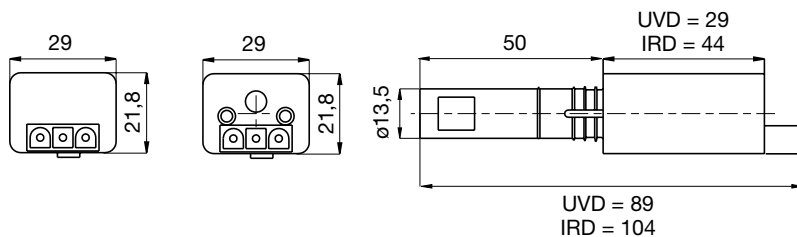

## HOLDER M 93 FOR IRD

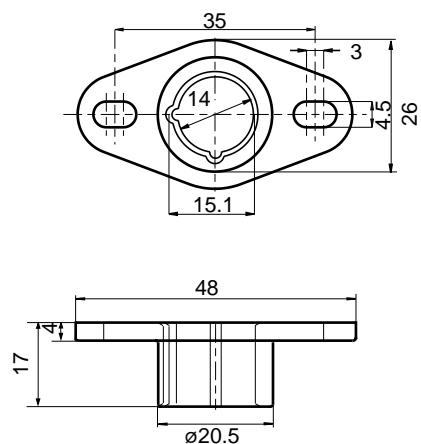

## VARIATION IRD

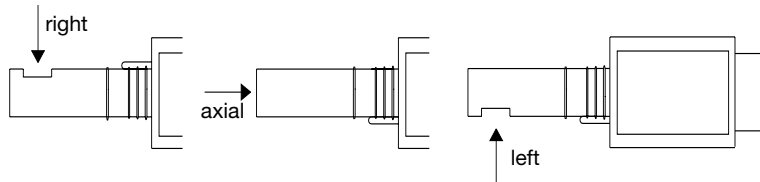

## ORDERING INFORMATION

ITEM	DESIGNATION	ITEM NO.
Control box	DMG 973 Mod. 01	0353001
Socket	Wiring base S98	75310
Insert plate	PG-Plate	70502
optional	Cable entry plate	70501
Flame detector	IRD 1020 end-on	16522
Flame detector	IRD 1020 left	16523
Flame detector	IRD 1020 right	16521
optional	UVD 971	16722
Support for IRD	Holder M93 for IRD 1020	59093
Support for UVD	Holder M74 for UVD	59074
Connection cable	Plug type, 3 core cable, 0.6 m with tag wire ends	7236001

The above ordering information refers to the standard version.  
Special versions are also included in our product range.

Specifications subject to change without notice

## DMG 973



A Honeywell Company

Satronic AG  
Brüelstrasse 7  
Postfach 324  
CH-8157 Dielsdorf

## Infrared Flicker Detector

**Flame monitoring device for oil and/or gas flames**

**With a row of 5 LED indicators and adjustable sensitivity**

### INTRODUCTION

The IRD 810 or 820 is employed to monitor the flame of an oil and/or gas burner. This flame monitoring device should be connected to a Satronic oil or gas burner control box. Monitoring is based on the infra-red flicker principle, in other words, the flickering infra-red light of the flame is detected. The steady radiation from, for example, the glowing refractory layer on the inside of the boiler, has no effect on the detector. The detectors are also available in 110 V versions or in an industrial version which has a particularly robust and water-proof detector probe.

### TYPES AVAILABLE

IRD 810	No potential difference at working contact 4-pole connection
IRD 820	With simulation of ionisation current For 3-pole connection to Satronic gas burner control boxes

### CONSTRUCTIONAL FEATURES

The monitoring device consists of the detector probe and the electronics. The infra-red sensor and the pre-amplifier are hermetically sealed in glass and along with the electronics form an integral part of the flame detector.

The indicator control unit contains a mains transformer and a relay which transmits the flame signal to the appropriate control box via a working contact which carries no other potential difference. Signal strength is indicated by a row of 5 LED's. Beside the LED's is a potentiometer for infinitely variable adjustment of the sensitivity.

A fixed cable runs between the flame detector and the indicator control unit. This cable must not be disconnected. Power is supplied through either a 3 or 4-core cable (live, neutral and flame signal).



### TECHNICAL DATA

Supply voltage	220 / 240 V (-15... +10%) 50 Hz (40 - 60 Hz)
Power consumption	2 VA
Max. current output terminal	2 A, 250 V
Permissible ambient temp.	-20° to +60° C
Insulation standard	IP 41
Mounting attitude	any
Weight	250 g
Flame viewing attitude	side-on and end-on
Spectral response	800 - 1100 nm
Max. sensitivity	950 nm
Frequency range	15 - 150 Hz
Max. sensitivity	30 Hz
Response time	0,1 sec.
Cancelling time	0,5 sec.
Cable length, detector - indicator ctrl. unit	
Normal version	0,5 m
Industrial version	1,0 m

## TECHNICAL FEATURES

1. Oil and/or gas flames can be monitored.
2. The flame detector and indicator control unit are suitable for operation where the ambient temperature lies within the range -20° to +60° C. (Please contact the manufacturer for information on higher temperatures.)
3. The working contact carries no potential difference, allowing the flame signal to be transmitted over large distances.
4. The influence of possible stray light during the pre-purge phase or the intensity of the flame when the burner is operating is indicated by the row of 5 LED's. The status of the relay is visible at any time.
5. Sensitivity is adjustable.
6. The compact dimensions of the detector allow it to be installed on any burner.
7. The industrial version differs from the normal version by having a larger, robust, absolutely waterproof detector.
8. Unlike UV tubes, the IRD 810/820 flicker detector does not deteriorate with age.

## INSTALLATION INSTRUCTIONS

1. The detector probe should be fitted so that it receives the light which pulsates most strongly. This can be achieved by positioning the detector as close as possible to the flame or by directing it at a particular zone of the flame.
2. No stray light must be allowed to fall on the detector (e.g. through cracks or from a sight glass). Pulsating stray light (e.g. from fluorescent lighting or light bulbs) could cause the system to switch to lockout.
3. The infra-red flicker detector should be fitted in such a way that the ambient temperature cannot under any circumstances rise above 60° C. At higher temperatures, there is a risk of incorrect operation and the life expectancy of the unit could be reduced. In addition, care should be taken that the detector is not subjected to unusually harsh vibration and receives no hard knocks.
4. The cable connecting the detector with the indicator control unit must not be disconnected. It must not, therefore, be shortened or lengthened.

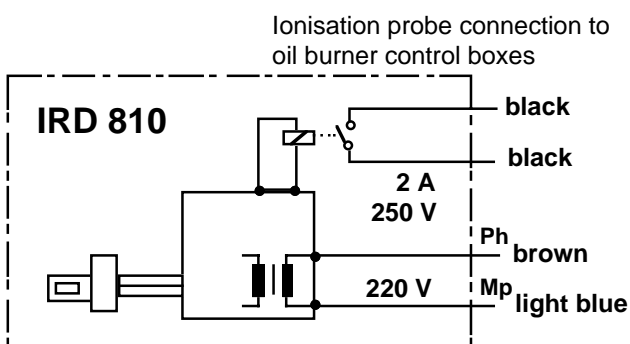

## COMMISSIONING AND MAINTENANCE

During commissioning and after servicing, the flame monitoring system should be checked for faultless operation as follows:

1. Check that the detector is connected properly. Wrong connections are a risk to safety, and could cause damage to the detector unit or burner system.
2. Adjust to maximum sensitivity and start the burner. After the start impulse, no LED should light up during the pre-purge phase.
3. With the system set for normal operation, pull out the detector probe and cover it up to cut off light. The LED indicators must go out. The control box should switch to lockout or attempt to restart the sequence.
4. Attempt to restart with the flame detector covered. There must be no indication from the LED's. The burner control box must switch to lockout at the end of the safety interval.
5. Attempt to start the burner with the detector exposed to stray light e.g. from fluorescent lighting, a cigarette lighter or light bulb (not daylight!). Depending on the type of control box, it should switch to lockout either immediately or at the end of the pre-purge, as a result of stray light.
6. Re-insert the detector into its mount. When the burner is operating normally, carefully turn back the sensitivity control until only one LED is lit. The control box must switch to lockout or restart the sequence.
7. Adjust the sensitivity to maximum. When the burner is operating normally, turn back the sensitivity control until only 4 LED's light continuously. We recommend this method of adjustment, because in this way, changes in the burner settings, dirty detector probe etc. or also the influence of stray light, can be detected very easily. (The internal relay is activated when 2 LED's light.)

The flame detection device requires no maintenance of any kind, and as it is classed as safety equipment, no attempt should be made to open the housing. The LED indicators should be checked visually at regular intervals. If a lower signal strength is indicated, it could mean that the burner settings have changed or that dirt and dust have reduced the amount of light reaching the detector.

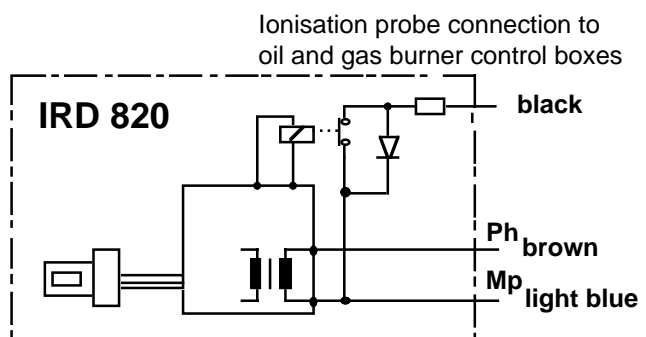

## FAULT FINDING

### 1. LED's light up during the pre-purge phase (control box switches to lockout):

- a) Stray light
- b) Ignition spark visible to detector (only oil burners)  
Correct by preventing direct sight of ignition spark or install Satronic high-frequency ignition transformer.
- c) Interference from ignition cable (lay cables some distance apart)
- d) Live and neutral wired incorrectly
- e) Burner not earthed/grounded
- f) Detector or indicator control unit defective

### 2. No indication from LED's after establishment of flame:

- a) Incorrect or faulty wiring
- b) Detector probe incorrectly installed („sees“ no light)
- c) Detector is dirty
- d) Sensitivity set at minimum
- e) Detector probe or indicator control unit defective

## CONNECTING THE IRD 810 TO SATRONIC OIL BURNER CONTROL BOXES (PHOTO-CELL CONNECTION)

Control box type corresponding terminal no.	IRD 810 - cable core colours				max. cable length IRD to control box (m)	
	brown	light blue	black	black	multiple cables	laid separately
TF 801	9	8	1	2	2	10
TF 802	9	8	1	2	2	10
TF 830	9	8	1	2	2	10
TF 832	9	8	1	2	2	10
TF 834	9	8 </td <td>1</td> <td>2</td> <td>2</td> <td>10</td>	1	2	2	10
TMO 720- 4	20	8	1	2	2	200

## CONNECTING THE IRD 820 TO SATRONIC OIL BURNER CONTROL BOXES (IONISATION PROBE CONNECTION)

Control box type corresponding terminal no.	IRD 820 - cable core colours				max. cable length IRD to control box (m)	
	brown	black	light blue		multiple cables	laid separately
MMI 810	9	2	8		2	200
MMI 812	9	2	8		2	200
MMG 810	9	2	8		2	200
TMG 740-2 / 740-3	20	1	8		2	200

### IRD 810 AND 820 DETECTOR

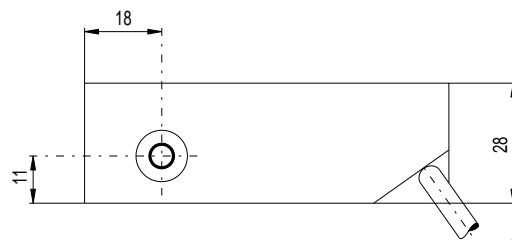

Connection to burner control box, standard cable length 0.5 m

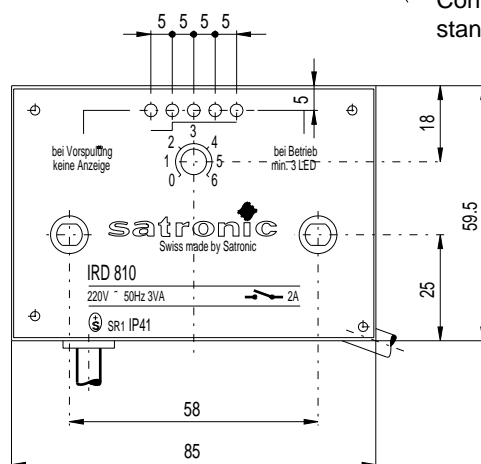
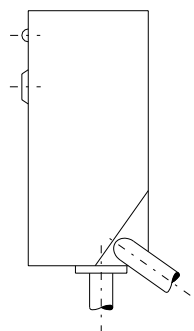

**IRD 810 AND 820 DETECTORS  
NORMAL VERSION**

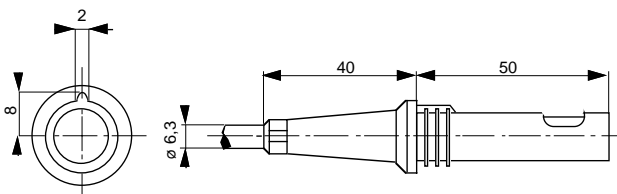

**M 74 DETECTOR MOUNT  
NORMAL VERSION**

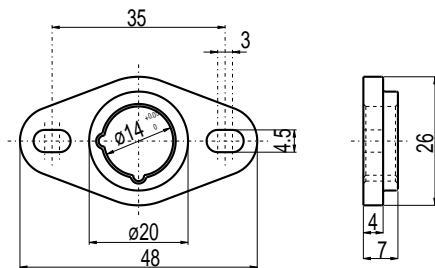

**IRD 810 AND 820 DETECTORS  
INDUSTRIAL VERSION**

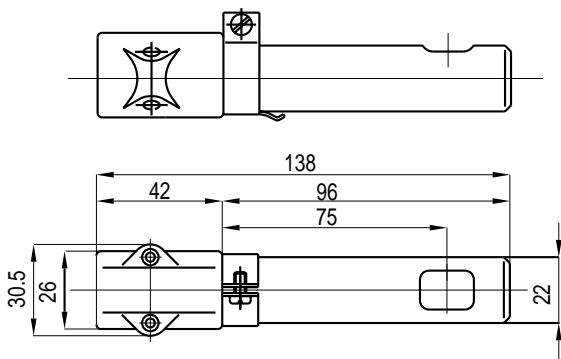

**DETECTOR MOUNT  
INDUSTRIAL VERSION**

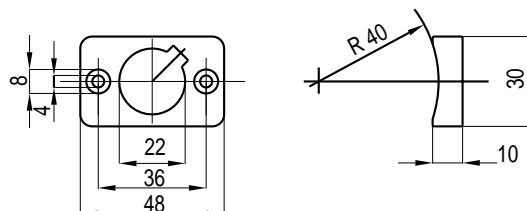

**ORDERING INFORMATION**

ITEM	DESIGNATION	ITEM NO.
Flame detector	IRD 810	16001
Flame detector	IRD 820	16201
Flame detector	IRD 810 Industrial	16002
Flame detector	IRD 820 Industrial	16202
Flame detector	IRD 810 110 volts	16021
Flame detector	IRD 820 110 volts	16221
Flame detector holder	FZ Holder M 68	59068
Flame detector holder	FZ Holder M 74	59074
Flame detector holder	FZ Holder M 75	59075
Holder	Industrial, UVZ + FZ	18807

The above ordering information refers to the standard version.  
Spezial versions are also included in our product range.

Specifications subject to change without notice.

**IRD 810 / 820**



Satronic AG  
Brüelstrasse 7  
Postfach 324  
CH-8157 Dielsdorf

## Infra-red flicker detector

**Flame monitoring device for yellow- or blue-burning oil flames**

### INTRODUCTION

The IRD 1010 is employed to monitor the flame of an oil burner. This flame monitoring device should be connected to a Satronic oil burner control box. Monitoring is based on the infra-red flicker principle, in other words, the flickering infra-red light of the flame is detected. The steady radiation from, for example, the glowing refractory layer on the inside of the boiler, has no effect on the detector. The IRD 1010 replaces the models IRD 910, 911 and 911 vi. If exchanging the units, care must be taken to connect them correctly (see page 3).

### TYPES AVAILABLE (also see page 4, Variants)

Item no.	Designation
16501	Flicker detector IRD 1010 right
16502	Flicker detector IRD 1010 end-on
16503	Flicker detector IRD 1010 left

The infra-red flicker detector is suitable for use with the following control boxes:

IRD 1010	DKO 970, 972, 974, 976 DKW 974, 976 DMO 976 TF 801, 802.1, 804 TF 830.1, 832.1, 834.1, 834E.1, 834.2, 836 TF 844, TF 974, 976 MMD 900, 900.1, TTO 872, 876 MMO 872, 876 TMO 720-4
----------	--

### CONSTRUCTIONAL FEATURES

The infra-red sensor and the pre-amplifier are hermetically sealed in glass and along with the electronics form an integrated unit in the flame detector. Wiring is by way of a plug connection. The sensitivity control and two LED's for indication of the flame signal are situated on the rear of the flicker detector.



### TECHNICAL DATA

Supply voltage	220 / 240 V (-15... +10%) 50 Hz (50 - 60 Hz)
Nominal current input	approx. 4 mA
Power consumption	1 VA
Ambient temperature	-20° C to +60° C
Insulation standard	IP 41
Mounting attitude	any
Weight	40 g
Flame viewing attitude	side-on or end-on according to type
Spectral response (with daylight filter)	800 - 1100 nm maximum 950 nm
Frequency range	15 Hz.... 250 Hz (-12 dB)
Sensitivity adjustment range	approx. 1 : 20 (26 dB)
Switch-on delay (after connecting operating voltage)	< 3.5 sec.
Response time	< 0.1 sec.
Cut-out time	< 1 sec.

## TECHNICAL FEATURES

### 1. Flame detection

- Yellow- as well as blue-burning oil flames can be monitored.
- The flame detector is suitable for operation where the ambient temperature is within the range -20° to +60° C.
- The flickering detector IRD 1010 becomes active not before a minimum threshold-level of steady light is exceeded. That guarantees that neither electromagnetic- nor ignition-spark noise are affecting the IRD.
- Sensitivity is adjustable.
- LED 1 is a warning indicator for the pre-purge phase as well as normal operation. LED 2 indicates the actual status of the detector: On or off.
- During pre-purge, LED 1 indicates possible stray light, which may be produced either by a flickering or by a steady light source, before the detector switches on (LED 2).
- When the burner is operating normally, LED 1 acts as a warning indication of the flame signal current sensitivity being set too low - it begins to flicker or extinguishes before the detector switches off.
- The compact dimensions of the detector allow it to be installed on any burner. The detector shaft has the same dimensions as the FZ 711 S. It therefore also fits into the FZ holder M 74.
- Unlike UV tubes, the IRD 1010 flicker detector does not deteriorate with age.

### 2. Installation instructions

- The detector probe should be fitted so that it receives the light which pulsates most strongly. This can be achieved by positioning the detector as close as possible to the flame or by directing it at a particular zone of the flame (e.g. by using a sighting tube).
- No stray light must be allowed to fall on the detector (e.g. through cracks or from a sight glass). Pulsating stray light (e.g. from fluorescent lighting or light bulbs) could cause the system to switch to lockout. Due to the very high sensitivity of the detector, it should not be exposed directly or indirectly (reflections) to the ignition spark.
- The infra-red flicker detector should be fitted in such a way that the ambient temperature cannot under any circumstances rise above 60 °C. At higher temperatures, there is a risk of incorrect operation and the life expectancy of the unit could be reduced. In addition, care should be taken that the detector is not subjected to unusually harsh vibration and receives no hard knocks.

## COMMISSIONING AND MAINTENANCE

During commissioning and after servicing, the flame monitoring system should be checked for faultless operation as follows:

1. Check that the detector is connected properly. Wrong connections are a risk to safety, and could cause damage to the detector unit or burner system.
2. Adjust to maximum sensitivity and start the burner: If the LED indicator is lit after the start impulse, carefully adjust the sensitivity control until LED 1 extinguishes. No LED should light up during the pre-purge phase.
3. With the system set for normal operation, pull out the detector probe and cover it up to cut off light. Both LED indicators must extinguish. The control box should switch to lockout or attempt to re-start the sequence.
4. Attempt to re-start with the flame detector covered. There must be no indication from the LED's after the start impulse. The burner control box must switch to lockout at the end of the safety interval.
5. Attempt to start the burner with the detector exposed to stray light e.g. from fluorescent lighting, a cigarette lighter or light bulb (not daylight or an electric torch): Depending on the type of control box, it should switch to lockout either immediately or at the end of the pre-purge, as a result of stray light.
6. When the burner is operating normally, carefully turn back the sensitivity control until LED 1 begins to flicker. Increase the setting again by one or two increments until both LED's are lit. If LED 1 does not flicker even at position 1: Leave potentiometer at position 1-2. This adjustment should be carried out when the flame signal current is weakest (shortly after flame establishment or after stabilisation).

The flame detection device requires no maintenance of any kind, and as it is classed as safety equipment, no attempt should be made to open the housing.

Because the nature of the flame can change in time due to the accumulation of dirt, the indicators on the detector should be checked periodically.

#### Please note:

Burner operating normally = both LED's on  
Burner in pre-purge phase = both LED's off

**For safety reasons the sensitivity must not be set higher than necessary.**

**Possible faults**

**1. LED's light up during the pre-purge phase (control box switches to lockout):**

- a) Sensitivity set too high
- b) Stray light
- c) Ignition spark visible to detector (directly or reflection). Correct by preventing direct sight of ignition spark.
- d) Interference from ignition cable (lay cables some distance apart, or possibly screen the detector).

**2. No indication from LED's after establishment of flame:**

- a) Incorrect or faulty wiring
- b) Sensitivity set too low
- c) Detector positioned wrongly (receives no light)
- d) Detector or viewing window dirty
- e) Defective detector

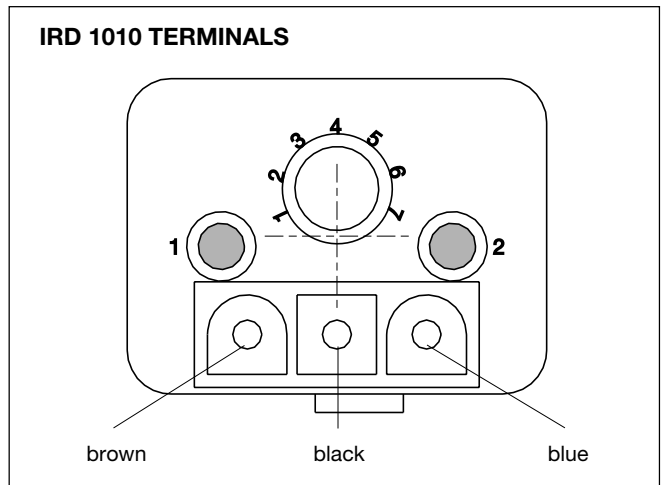

**CONNECTION OF IRD 1010 TO SATRONIC BURNER CONTROL BOXES**

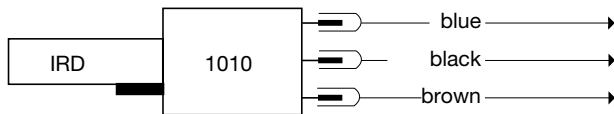

Control box type	TF 8..	TF 9..	DKO 9.. DKW 9.. DMO 9..
Terminal no.	2	7	2
Terminal no.	1	1	1
Terminal no.	9	9	9

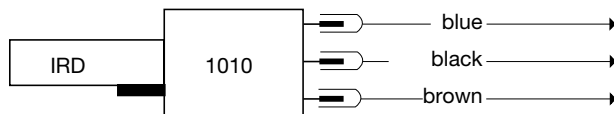

Control box type	MMD 900 MMD 900.1	TTO 872 <sub>1)</sub> TTO 876 <sub>1)</sub>	MMO 872 <sub>1)</sub> MMO 876
Terminal no.	2	1 or 8	1 or 8
Terminal no.	1	2	2
Terminal no.	9	9	9

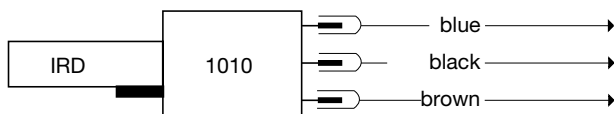

Control box type	TMO 720-4
Terminal no.	2
Terminal no.	1
Terminal no.	9

1) By installing the IRD/TTO adaptor cable (Item no. 72002) between the IRD/TTO and the detector cable in conjunction with the TTO 8.. or MMO 8.. control boxes, the uniform system of baseplate wiring (blue = terminal 2, brown = terminal 9, black = terminal 1) can be adhered to.

The standard-sensitive version of the IRD 1010 has a **blue** inprint. **White** or **red** inprints are marking detectors with special attributes. They may be used only on burners which are approved for these detectors.

**HOLDER M74**

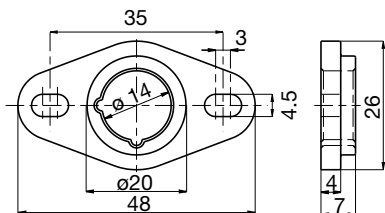

**FLICKER DETECTOR IRD 1010**

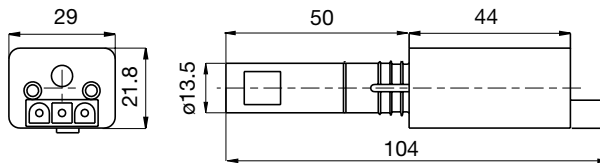

**VARIANTS**

Light entrance from right Item no. 16501

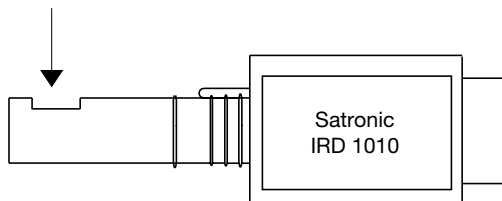

End-on light entrance Item no. 16502

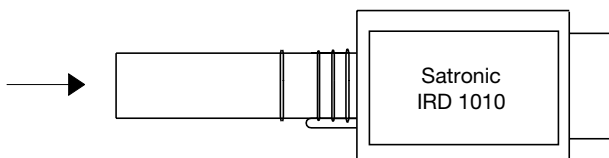

Light entrance from left Item no. 16503

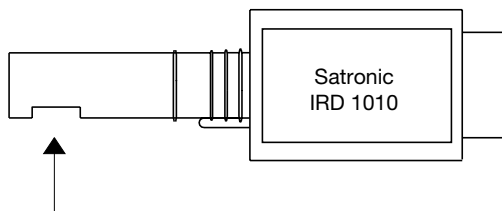

**ORDERING INFORMATION**

ITEM	DESIGNATION	ITEM NO.
Flame sensor	Flicker detector IRD 1010 right	16501
optional	Flicker detector IRD 1010 end-on	16502
optional	Flicker detector IRD 1010 left	16503
Mounting flange	Holder M74	59074
Connection cable	Plug type, 3 core cable, 0.6 m with tag wire ends	7236001

The above ordering information refers to the standard version.  
Special versions are also included in our product range.

Specifications subject to change without notice.

**IRD 1010**



Satronic AG  
Brüelstrasse 7  
Postfach 324  
CH-8157 Dielsdorf

## Infra-red flicker detector

**Flame detection device for  
oil and gas flames**

### INTRODUCTION

The IRD 1020 detector is used to supervise gas or oil flames. This flame monitoring device should be connected to a Satronic oil burner control box. Monitoring is based on the infra-red flicker principle, in other words, the flickering infra-red light of the flame is detected. The steady radiation from, for example, the glowing refractory layer on the inside of the boiler, has no effect on the detector. The IRD 1020 replaces the IRD 920. When exchanging the units, care must be taken to wire them correctly.

### TYPES AVAILABLE (also see page 4)

Item no.	Designation
16521	Flicker detector IRD 1020 side-on-right
16522	Flicker detector IRD 1020 end-on viewing
16523	Flicker detector IRD 1020 side-on left

The infra-red flicker detector can be used with any one of the following control boxes:

IRD 1020	DKG 972
	DLG 974, 976
	DMG 970, 971, 972, 973
	TFI 812.2
	MMI 810, 811, 812, 815, 816, 962
	MMG 810, 811, 816,
	TMG 740-2, 740-3
	SGU 930, 930i

### CONSTRUCTIONAL FEATURES

The infra-red sensor and the pre-amplifier are hermetically sealed in glass and along with the electronics form an integrated unit in the flame detector. Wiring is by way of a plug connection. The sensitivity control and two LED's for indication of the flame signal are situated on the rear of the flicker detector.



### TECHNICAL DATA

Supply voltage	220 / 240 V (-15... +10%) 50 Hz (50 - 60 Hz)
Nominal current input	approx. 4 mA
Power consumption	1 VA
Ambient temperature	-20° C to +60° C
Insulation standard	IP 41
Mounting attitude	any
Weight	40 g
Flame viewing attitude	side-on or end-on according to type
Spectral response (with daylight filter)	800 - 1100 nm maximum 950 nm
Frequency range	15 Hz.... 250 Hz (-12 dB)
Sensitivity adjustment range	approx. 1 : 20 (26 dB)
Switch-on delay (after connecting operating voltage)	< 3.5 sec.
Response time	< 0.1 sec.
Cut-out time	< 1 sec.

## TECHNICAL FEATURES

### 1. Flame detection

- Yellow- as well as blue-burning oil- and gas flames can be monitored.
- The flame detector is suitable for operation where the ambient temperature is within the range  $-20^{\circ}$  to  $+60^{\circ}$  C.
- The flickering detector IRD 1020 becomes active not before a minimum threshold-level of steady light is exceeded. That guarantees that neither electromagnetic- nor ignition-spark noise are affecting the IRD.
- Sensitivity is adjustable.
- LED 1 is a warning indicator for the pre-purge phase as well as normal operation. LED 2 indicates the actual status of the detector: On or off.
- During pre-purge, LED 1 indicates possible stray light, which may be produced either by a flickering or by a steady light source, before the detector switches on (LED 2).
- When the burner is operating normally, LED 1 acts as a warning indication of the flame signal current sensitivity being set too low - it begins to flicker or extinguishes before the detector switches off.
- The compact size makes it possible to mount the detector on any burner. For this reason the IRD mounting flange M93 has the same dimensions and fixing holes as the FZ flange M74. This magnetic flange provides the switch-off facility specified in the European standard. The IRD 1020 therefore only functions with the M93 flange.
- Unlike the ultra-violet cell, the parameters of the IRD 1020 do not change with ageing.

### 2. Installation instructions

- The detector probe should be fitted so that it receives the light which pulsates most strongly. This can be achieved by positioning the detector as close as possible to the flame or by directing it at a particular zone of the flame (e.g. by using a sighting tube).
- No stray light must be allowed to fall on the detector (e.g. through cracks or from a sight glass). Pulsating stray light (e.g. from fluorescent lighting or light bulbs) could cause the system to switch to lockout. Due to the very high sensitivity of the detector, it should not be exposed directly or indirectly (reflections) to the ignition spark.
- The infra-red flicker detector should be fitted in such a way that the ambient temperature cannot under any circumstances rise above  $60^{\circ}$  C. At higher temperatures, there is a risk of incorrect operation and the life expectancy of the unit could be reduced. In addition, care should be taken that the detector is not subjected to unusually harsh vibration and receives no hard knocks.
- It is necessary for the magnetic IRD M93 flange to be mounted on a flat surface to avoid any mechanical stress which could otherwise damage it.

## COMMISSIONING AND MAINTENANCE

During commissioning and after servicing, the flame monitoring system should be checked for faultless operation as follows:

- Check that the detector is connected properly. Wrong connections are a risk to safety, and could cause damage to the detector unit or burner system.
- Adjust to maximum sensitivity and start the burner: If the LED indicator is lit after the start impulse, carefully adjust the sensitivity control until LED 1 extinguishes. No LED should light up during the pre-purge phase.
- With the system set for normal operation, pull out the detector probe and cover it up to cut off light. Both LED indicators must extinguish. The control box should switch to lockout or attempt to re-start the sequence.
- Attempt to re-start with the flame detector covered. There must be no indication from the LED's after the start impulse. The burner control box must switch to lockout at the end of the safety interval.
- Attempt to start the burner with the detector exposed to stray light e.g. from fluorescent lighting, a cigarette lighter or light bulb (not daylight or an electric torch): Depending on the type of control box, it should switch to lockout either immediately or at the end of the pre-purge, as a result of stray light.
- When the burner is operating normally, carefully turn back the sensitivity control until LED 1 begins to flicker. Increase the setting again by one or two increments until both LED's are lit. If LED 1 does not flicker even at position 1: Leave potentiometer at position 1-2. This adjustment should be carried out when the flame signal current is weakest (at a cold-start, shortly after flame establishment or after stabilisation).

The flame detection device requires no maintenance of any kind, and as it is classed as safety equipment, no attempt should be made to open the housing.

Because the nature of the flame can change in time due to the accumulation of dirt, the indicators on the detector should be checked periodically.

#### Please note:

Burner operating normally = both LED's on  
Burner in pre-purge phase = both LED's off

**For safety reasons the sensitivity must not be set higher than necessary.**

#### Safety Checks:

1. Shut off the fuel supply when the burner is in the "run" position. The indicator LEDs should extinguish and the control box go to lockout.
2. Start the burner with the fuel supply shut off. The control box must go to lockout at the end of the safety time due to absence of flame.
3. Remove the detector from its mounting flange during a pause, fit onto it a second flange M93. Start the burner with straylight on the detector (e.g. by a cigarette-lighter, bulb or a neonlight. Daylight or a torch is not suitable). The control box must go to lockout due to stray light either immediately or at the end of the pre-purge, depending on the model.

#### Test switch-off facility:

1. Remove the detector during the "run" position from its special M93 flange. The control box must go to lockout due to the activated switch-off facility.

**Possible faults**

**1. LED's light up during the pre-purge phase (control box switches to lockout):**

- a) Sensitivity set too high
- b) Stray light
- c) Ignition spark visible to detector (directly or reflection). Correct by preventing direct sight of ignition spark.
- d) Interference from ignition cable (lay cables some distance apart, or possibly screen the detector).

**2. No indication from LED's after establishment of flame:**

- a) Incorrect or faulty wiring
- b) Sensitivity set too low
- c) Detector positioned wrongly (receives no light)
- d) Detector or viewing window dirty
- e) Defective detector
- f) IRD flange M93 defective (cracks or other mechanical defects)

**IRD 1020 TERMINALS**

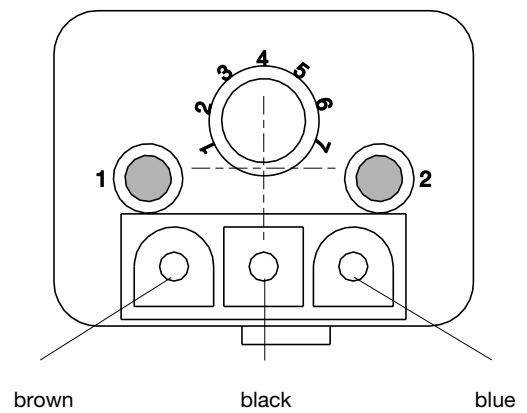

**CONNECTION OF IRD 1020 TO SATRONIC BURNER CONTROL BOXES**

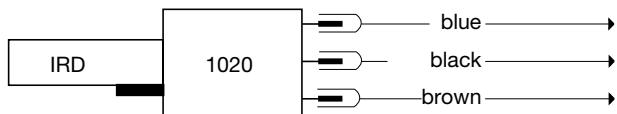

Control box type	TFI 812	DKG 97. DLG 97.	DMG 97.
Terminal no.	8	8	8
Terminal no.	1	1	2
Terminal no.	9	9	9

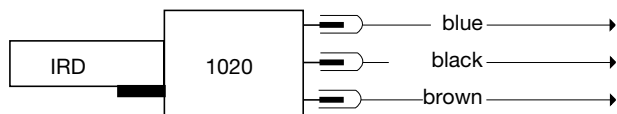

Control box type	MMI	MMG
Terminal no.	8	8
Terminal no.	2	2
Terminal no.	9	9

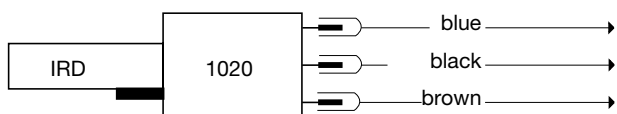

Control box type	TMG 740	SGU 930(i)
Terminal no.	8	N
Terminal no.	1	15
Terminal no.	20	1

The standard-sensitive version of the IRD 1020 has a **blue** inprint. **White** or **red** inprints are marking detectors with special attributes. They may be used only on burners which are approved for these detectors.

**HOLDER M93**

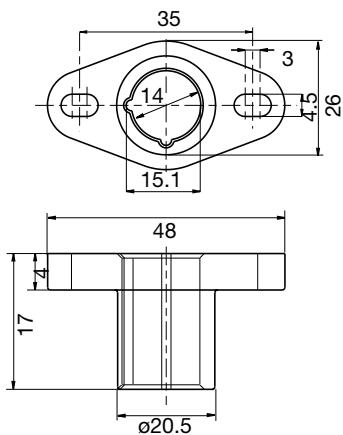

**FLICKER DETECTOR IRD 1020**

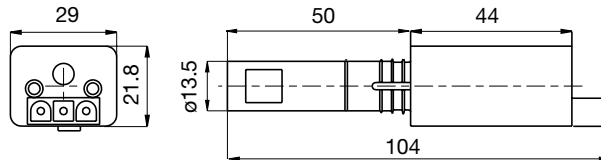

**VARIANTS**

Light entrance from right    Item no. 16521

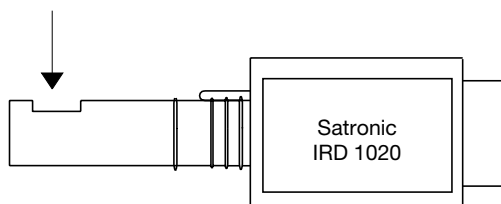

End-on light entrance    Item no. 16522

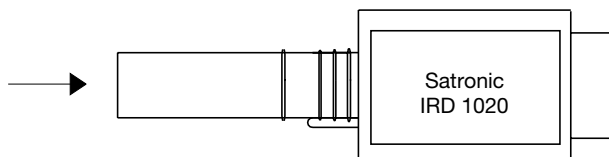

Light entrance from left    Item no. 16523

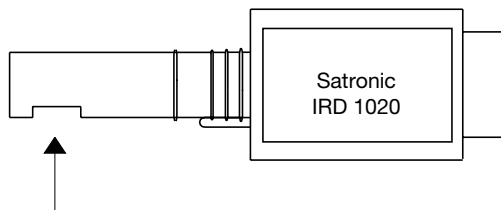

**ORDERING INFORMATION**

ITEM	DESIGNATION	ITEM NO.
Flame sensor	Flicker detector IRD 1020 side-on right	16521
optional	Flicker detector IRD 1020 end-on viewing	16522
optional	Flicker detector IRD 1020 side-on left	16523
Mounting flange	Flange M93	59093
Sensor cable	Plug type, 3-wire, 0.6 m with tag wire ends	7236001

The above ordering information refers to the standard version.  
Special versions are also included in our product range.

Specifications subject to change without notice.

**IRD 1020**



Satronic AG  
Brüelstrasse 7  
Postfach 324  
CH-8157 Dielsdorf

# Oil Flow Meter and Hours of Operation Counter

For single or two-stage oil burners with throughputs from 1 to 40 l/h

- multifunctional
- mains or battery powered

## INTRODUCTION

The oil flow meter and hours of operation counter is used on single or two-stage burners with throughput rates from 1 to 40 l/h of heating oil EL. It provides the user with various information, such as oil consumption, number of starts, hours of operation, etc. plus a warning indication if the flow rate falls below a preset nominal level, due to either an obstructed nozzle or filter. By identifying problems with the oil flow, inefficient combustion and air pollution may be corrected.

The sensor is mounted between the oil pump and the nozzle.

The display can be mounted anywhere on the burner. It is available in either a mains or battery powered version.

## CONSTRUCTIONAL FEATURES

The sensor is an oval tooth-wheeled counter with very small dimensions (30 x 30 x 34 mm). The enclosed oil volume is only 2 ccm. The material used guarantees high accuracy and long life. A filter, which is easy to change, protects the sensor from any floating particles.

The display is enclosed in a plastic housing, which fits into a standard 22.2 x 45 mm cutout. Located on the front are a LCD display (6 digits, with leading-zero suppression, metered units, warning and operating mode symbols) and a push button switch for selecting the operating mode and resetting.

Connectors for the sensor and power cable, plus a code switch to select the operating mode, are located on the back. The connector for the power supply is only mounted on the mains powered version. The battery is located in a battery box.

The sensor is connected to the display by a 2 wire plug and cable.

## TYPES AVAILABLE

SOG 960	sensor for heating oil EL
SOZ 960 B	display with battery
SOZ 960 N	display for mains supply



## TECHNICAL DATA

### Sensor SOG 960 for heating oil EL

Throughput	1 to 40 l/h
Max. pressure	< 25 bar
Ambient temp. range	0 to 60° C
Accuracy	±2,5% (at a volumetric weight of 830 g/dm <sup>3</sup> )
Oil volume	2 ccm
Loss of pressure	≤ 0.1 bar
Electrical connection	2-wire AMP connector Modu 2 system
Oil connection	R 1/8"
Mounting attitude	Any
Weight	110 g

### Display general

Front dimensions	48 x 24 mm
Cutout	45 x 22,2 mm (DIN 43700)
LCD display	6-digits, w. leading zero suppres.
Digit size	8 mm
Ambient temperature	0 to 60° C
Insulation standards (IEC 144)	Front IP 65 Connectors IP 20
Mounting attitude	Any

### Display SOZ 960 N mains

Supply voltage	220 / 240 V (-15... +10%) 50 Hz (40-60 Hz)
Current	10 mA
Power connector	2 wire Satronic connector
Sensor connector	2 wire AMP connector Modu 2 system
Display visible after loss of power	ca. 24 h (0-Serie: ca. 3 h)

### Display SOZ 960 B battery

Lifetime of battery	ca. 5 years (0-Serie: ca. 3 years)
End-of-life warning	> 1 year before end-of-life
Data held during battery change	2 minutes
Battery	CR 14250, 3 V, 850 mAh
Sensor connector	2 wire AMP connector Modu 2 System

## TECHNICAL FEATURES

### 1. Combination of display and sensor

Display and sensor can be mixed, if the digits of the type are matching, e.g.:

SOZ 960 B + SOG 960 or  
SOZ 960 N + SOG 960

### 2. Operation of battery-powered type

Displays with batteries need no mains and are, therefore, especially suitable for adding to burners in the field. The lifetime of the battery is approximately 5 years. One year before the end-of-life, the crossed battery symbol  appears on the display.

### 3. Operation of mains powered type

The display is connected to the mains (220 / 240 V AC) by means of a 2 wire plug and cable. The display disappears 2 days after loss of power. All data is retained and can be displayed when power is restored.

Set- and reset functions are not possible at mains interruption.

### 4. Mounting and installation

The sensor is connected by R 1/8" screw fittings into the oil tube between the oil pump and nozzle in the flow direction as stated on the sensor (any mounting attitude). The display can also be mounted in a panel with a 45 x 22.2 mm cut-out. The connection between the sensor and the display is made by a 2 wire cable and plug. For the power connector (mains version only), the appropriate standards must be complied with.



Inside view

## COMMISSIONING AND MAINTENANCE

### 1. Function of the push button mode

By pressing the push button, the various modes can be selected in succession. Each mode is displayed by its function symbol as well as the appropriate unit. The selected mode remains present until the push button is pressed again. The new function is first displayed when the push button is released. With the same push button, the reset signals for the sum-counter, total reset and threshold levels (for the service function) are generated.

Mode	Function	7-digit display	unit
	actual consumption	6-digits 2 decimal places (0000.00)	Oilflow in liter per hour (l/h)
2.	actual consumption 2nd stage	6-digits 2 decimal places (0000.00)	Oilflow in liter per hour (l/h)
◇	sum counter (resetable)	6-digits 0 decimal places (000000)	Oilflow in liter (l)
*	totalizer	6-digits 0 decimal places (000000)	Oilflow in liter (l)
⌚	total hours of operation	6-digits 0 decimal places (000000)	hours of operation (h)
⌚	number of starts	6-digits 0 decimal places (000000)	number of starts
2.⌚	hours of operation, 2nd stage	6-digits 0 decimal places (000000)	hours of operation 2nd stage (h)
⌚ 2.	number of starts, 2nd stage	6-digits 0 decimal places (000000)	number of starts 2nd stage

#### Function



Service

reduced flow rate



battery life cycle < 1 year

## 2. Selection of the operating mode

2 operating modes can be selected by setting the code switches on the back.

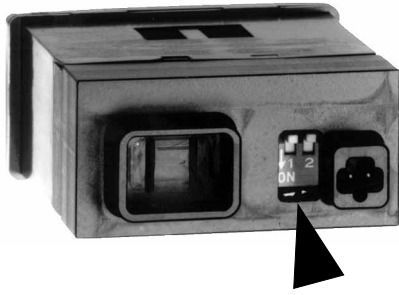

### Code switch 1 to "off" (default, factory setting)

Single stage burner (also with soft start function)  
The following functions will be displayed:

- actual consumption
- ◇ sum counter
- \* totalizer
- 🕒 total hours of operation
- ⌋ number of starts
- ⚠️ Service reduced flow rate
- 🔋 battery life cycle < 1 year

### Code switch 1 set to "ON"

Two-stage burner, for genuine 2 stage operation.  
All possible functions will be displayed.

### Code switch 2 has no function

## 3. Sum counter reset

In the mode ◇, function sum counter, resetting the sum counter can be done by this procedure:

-> *press the button for at least 10 secs.*

press the button, after 5 secs. the displayed value flashes for 5 secs. After this, the original value is displayed continuously, now release the button  $\begin{matrix} \text{I} \\ \text{I} \end{matrix}$ , is now displayed.

## 4. Total reset

A total reset is possible, but should only be done with the agreement of the manufacturer

## 5. Service function

Besides displaying various data such as actual consumption, number of starts and hours of operation, it will also detect whether the oil throughput has fallen by more than 10% of the nominal value, due to either an obstruct in the nozzle or preheater failure; on condition the value of the throughput has been presetted previously at a correct operating burner (see item 6). If after the reset routine the throughput has fallen by more than 10%, the service symbol  $\begin{matrix} \text{I} \\ \text{I} \end{matrix}$  will appear.

By recognising and solving this problem, long term inefficiency and air pollution can be avoided.

## 6. Determining the momentary throughput

Determining the momentary throughput is done in the normal mode, function actual consumption:

-> *press the button for at least 30 secs., but not longer than 32 secs.*

press the button, after 25 secs. the displayed actual consumption flashes for 5 secs. After the display stopps flashing, release the button. As a confirmation, the service symbol  $\begin{matrix} \text{I} \\ \text{I} \end{matrix}$  and the actual consumption as the new defined preset value flash for 5 secs.

On 2-stage burners, preset levels for both stages can be stored. After a change of the heat rating (replaced nozzle, different pump pressure etc.), the preset value has to be newly determined as described above. The original value will be overwritten by the new value.

## 7. Deactivation of the service function

Same procedure as under item 6 but the button has to be pressed for more than 32 secs. By doing this, the preset value and the service symbol will be resetted:

-> *press the button for more than 32 secs.*

After releasing the button, as a confirmation the service symbol  $\begin{matrix} \text{I} \\ \text{I} \end{matrix}$  and the zero-value flash for 5 secs.

## 8. Maintenance, Filter

To avoid obstruction of the sensor, as a precaution a microfilter has to be installed upstream of the burner. Filter size: less than or equal to 150 µm.

To trap single floating particles, a rough filter is built into the sensor.

**OVERALL DIMENSIONS SOZ**

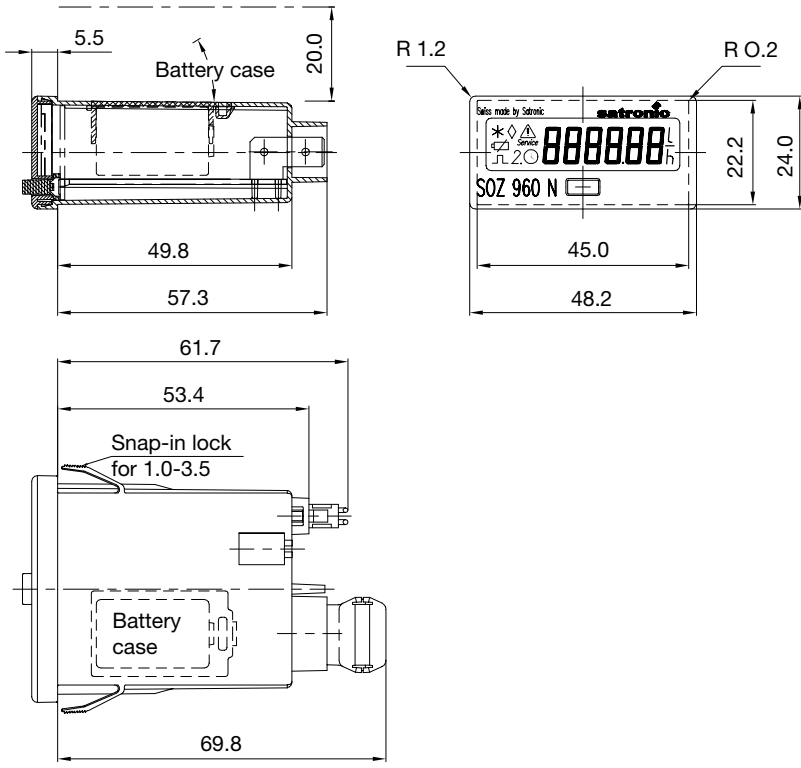

**OVERALL DIMENSIONS SOG**

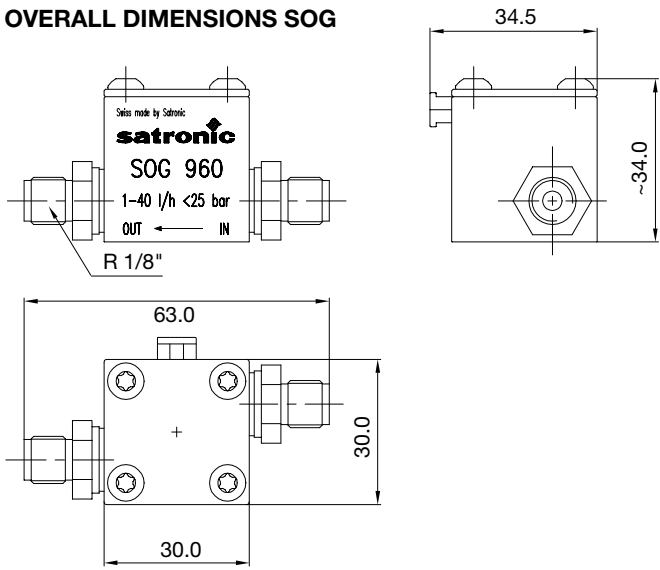

**ORDERING INFORMATION**

ITEM	DESIGNATION	ITEM NO.
sensor for heating oil EL	SOG 960	21010
display with battery	SOZ 960 B	21110
display for mains supply	SOZ 960 N	21120
power cable for display L 500 mm	power cable 2-wire 0.5 m	7295001
connection cable sensor/display L 900 mm	connection cable SOG/SOZ 0.9 m	72090

The above ordering information refers to the standard version. Special versions are also included in our product range.

Specifications subject to change without notice.

**SOG 960**  
**SOZ 960**



Satronic AG  
Brüelstrasse 7  
Postfach 324  
CH-8157 Dielsdorf

## Leakage Monitor

**Automatic leakage monitor with 2 series-connected gas valves. Suitable for testing with a vacuum or with two bypass valves.**

### BRIEF DESCRIPTION

The automatic leakage monitor MDP 720-1 automatically controls and monitors any leakage of two series-connected gas valves. This testing is performed directly after each normal shutdown. The same instrument allows testing for leakage by using a vacuum pump or two bypass valves. The operation itself can be monitored on the incorporated programme display. The bypass testing system at the reset display indicates which of the valves is leaking.

Terminals have been provided for: control circuit of the automatic firing assembly, pressure switch or vacuum switch, 2 bypass valves or vacuum pump, air damper (open, dead) blower motor of the burner, external lockout display and remote reset.

By connecting the MDP 720-1 with a Satronic automatic gas firing system of the TM series, a perfect performance of leakage control is checked intrinsically safely. If the MDP 720-1 for whatever reason does not perform a leakage test after a normal shut-down, the blower motor does not turn off. With the following normal start-up, the air proving switch in its operating position prevents the burner from starting.

The leakage test may be performed in either of 2 ways. In one case, 2 small bypass valves first drain the gas pressure of the 2 main valves and, after the testing period, bring it back up to the mains pressure. A gas pressure switch checks if, during test periods after "draining" or "filling", the pressure does not rise or drop. If it does, the MDP is subjected to a lockout. Normally, the control circuit is released for the next normal start-up after the testing operation.

In the second case, the vacuum pump creates a vacuum between the two gas valves. The vacuum thus created should be greater than 300 mm water head. Next, the vacuum switch during the testing period checks if the vacuum is maintained. If not, a lockout will be switched. The sensitivity of this set is easy to calculate. The following variables must be assumed known:  $V_p$  = gas volume between the two valves in liters,  $P$  = mains gas pressure or vacuum in mm water head. The response sensitivity in liters per hour then is:

$V_p(1) \times p(\text{mm water head}) \times 0.003$ . The response level of the pressure or vacuum switch should be approx. half of the mains pressure, respectively at half the vacuum level.



The automatic system with the synchronous motor is incorporated into a plug-in type plastic housing. The top of the instrument holds the release button with a visual alarm display.

Plug-in boards with various cable ducts are provided on two sides of the wiring base. This makes for an easy access to an efficient wiring of terminals.

### TECHNICAL DATA

Operating voltage	220 / 240 V (-15... +10%) 50 Hz (40 - 60 Hz)
Deviating frequency	results in proportional deviation of periods
Prefusing	10 A quick-action or 6 A slow-action
Internal consumption	15 VA
Max. load per output	4 A
	total 6 A
Approved by	DVGW
Testing periods	approx. 50 sec. each
Filling and draining periods	approx. 6.5 sec. each
Operating period of the vacuum pump	approx. 50 sec.
Pressure or vacuum switch contact:	1 changeover contact 100 mA 220 V~
Ambient temperature	-20° C to +60° C
Weight	approx. 750 g
Type of protection	IP 41

### Important

For installations in the Netherlands, the type MDP 720-1 Mod. NL has to be used (cycle time 60 sec. instead of 120 secs.)

## LEAKAGE TEST WITH BYPASS VALVES

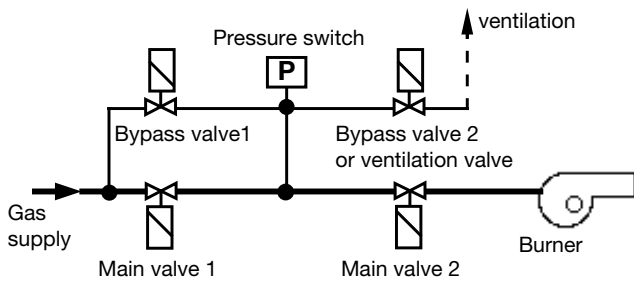

## LEAKAGE TEST WITH VACUUM PUMP

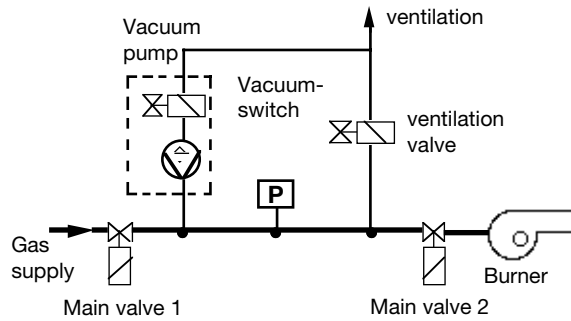

### PLEASE NOTE

Check the wiring before starting the system. Faulty wiring may result in damages to the monitor system and endanger the safety of the system.

The instrument may be plugged in or unplugged only when the main switch is set on **OFF**. The trigger point of the pressure switch in the bypass system, or the vacuum switch in the vacuum system, must be set for half of the mains pressure, respectively the vacuum level.

### FUNCTION CHECK

Perform the following checks when starting or auditing the system:

#### Bypass system

Testing operation with bypass valve 1 (BV 1), disconnected from terminal 5:

After the testing period V2, the instrument switches to lockout (end of yellow area). Testing operation with bypass valves (BV 1, Term. 6, BV 2, Term. 5) connected transposed:

After the testing period V1, instrument switches to lockout (end of yellow area).

#### Vacuum system

Testing operation with vacuum pump disconnected from terminal 3. After the testing period, instrument switches to lockout (end of yellow area).

### SAFETY AND SWITCH FUNCTIONS

If the pressure or the vacuum switch contact is stuck, a lockout will be the result in any case. In both systems, leakage of the auxiliary valves is also checked. A burner start-up without a preceding leakage test concluded positively is impossible. The blower motor of the burner is switched from the MDP. If for any reason the leakage programme does not start-up in a normal shut-down, the blower motor does not turn off. For the next normal switch-on, there is no burner start-up since the air proving switch contact remains in its operating position.

### FAULT FINDING

Testing programme does not operate, programme remains in the white area:

-> No phase on terminal 9, automatic burner assembly on lockout.

Programme sequence stops in the black area:

-> Connection terminal 17 to terminal 18 (bypass) or terminal 18 to terminal 19 (vacuum) is missing.

Blower motor does not start:

-> No feedback from the automatic burner assembly on terminal 4.

Blower motor does not turn off:

-> Permanent phase on terminal 4, programme switching system defective.

# CONNECTION DIAGRAMM AND PROGRAMM SEQUENCE

Automatic Burner Type TMG

\* For systems equipped with a ventilation valve bypass valve BV 2 may be waived

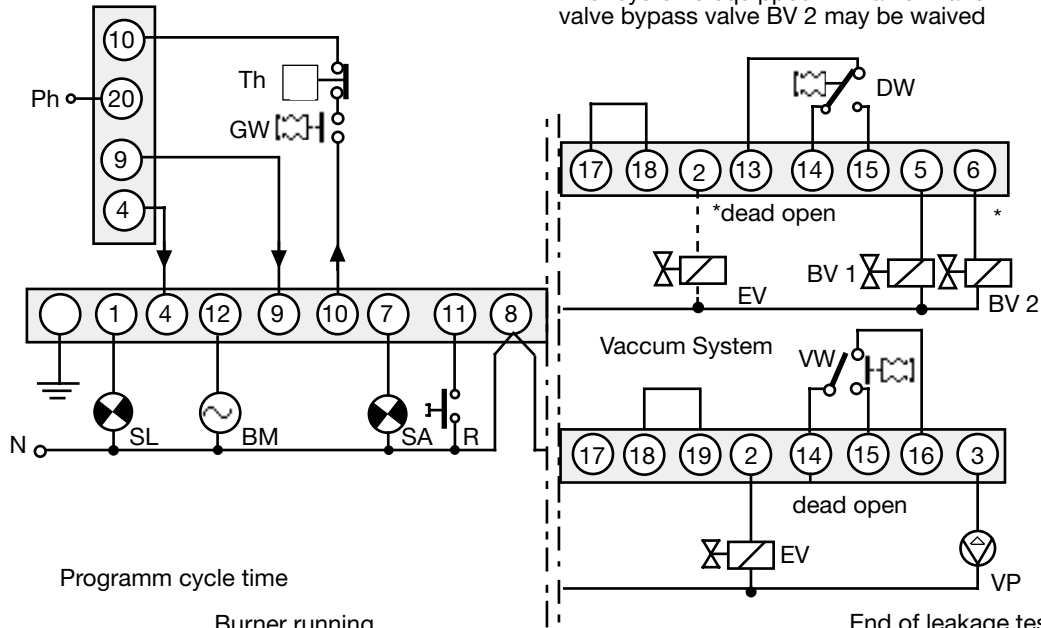

Programm cycle time

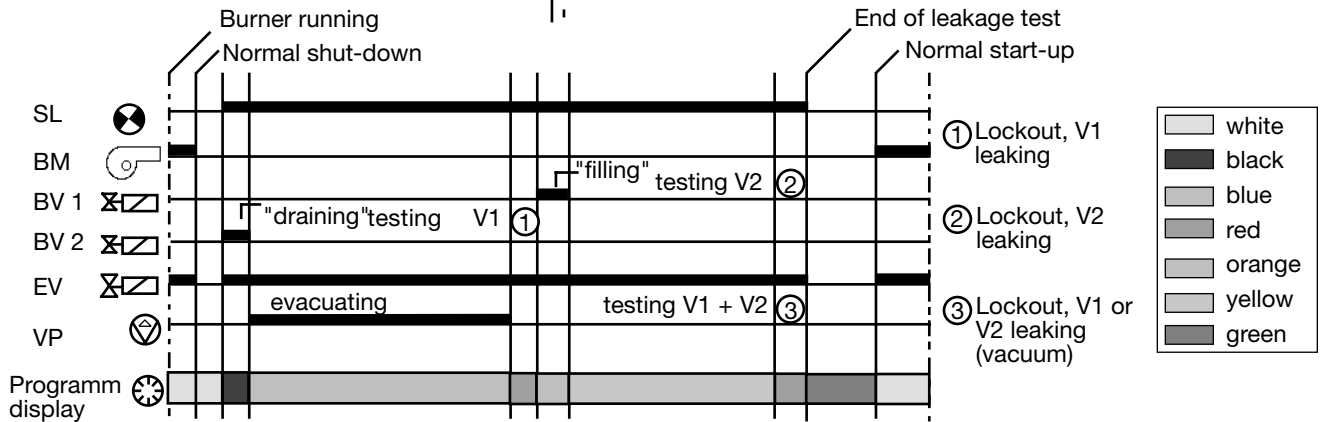

SL signal lamp, leakage test  
 BM Blower motor, burner  
 SA External lockout signal

R Reset button, external  
 DW Pressure switch  
 EV Ventilation valve, dead open

BV1 Bypass valve 1  
 BV2 Bypass valve 2  
 VW Vacuum switch  
 VP Vacuum pump

**MDP 720-1 WITH BASE**

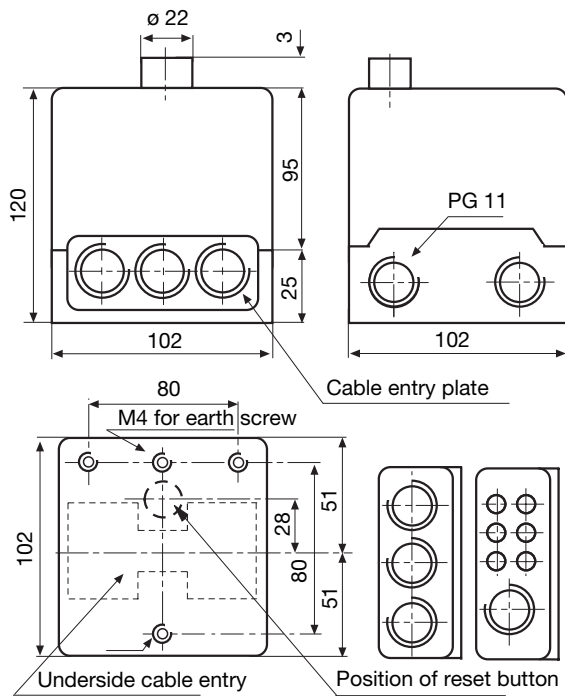

**ORDERING INFORMATION**

ITEM	DESIGNATION	ITEM NO.
leakage test device	MDP 720-1	08905
leakage test device	MDP 720-1 NL	08906
Base	Base MDP	70215
cable entry plate	cable plate	70501
alternative	PG-plate	70502

The above ordering information refers to the standard version.  
Special versions are also included in our product range.

Specifications subject to change without notice.

**MDP 720-1**

**satronic**  
A Honeywell Company

Satronic AG  
Brüelstrasse 7  
Postfach 324  
CH-8157 Dielsdorf

# Regulator

**Regulator for modulating burners allowing exact regulation of pressure or temperature**

## INTRODUCTION

The UPR 770 is a fully electronic regulator with no mechanical movement, which operates with "P" characteristics (proportional). It is designed to accurately regulate temperature or pressure in heating, ventilation or air-conditioning systems, and is particularly suitable for maintaining a constant pressure or temperature inside a heating system boiler while the output of the modulating burner is varied. Deviations from the nominal value are evaluated by an integrated circuit differential amplifier. As well as greatly amplifying the signal which indicates a deviation, the amplifier remains extremely stable, being insensitive to zero point drift, ambient temperature variations and fluctuations in the mains voltage. Output from the regulator is via two contacts which demand "more" or "less" power from the system it is regulating.

Three potentiometers for initial adjustment of the regulator are positioned on the front plate together with the "+" and "-" indicator lamps. The main regulating potentiometer (for setting the desired pressure or temperature value) has an easily-read scale, and can be locked at the required setting. This potentiometer is of the plug-in type, making it very easy and convenient to keep a range of potentiometers with the required values available, and also providing the possibility of connecting an external (remote) main potentiometer. When the regulator is operated together with the FED 621 photo-electric pressure sensor, the jumper wire on the underside of the unit must be cut.

Terminals are provided for the following:

- Resistance thermometer Pt 100  $\Omega$  / 0° C
- Main potentiometer for setting the required value according to the standard measurement range or a special range as specified by the customer
- Feedback potentiometer 100 E
- FED 621 photo-electric pressure sensor
- Regulating device (2 switching contacts which carry no other voltage)

## CONSTRUCTIONAL FEATURES

The regulator is enclosed in a plug-in type plastic housing. All operating controls and the central fastening screw are situated on the front of the housing.

The wiring base is equipped with additional live, neutral and earth terminals which, together with the various cable entry points, ensure easy-to-follow and efficient wiring of the unit.



## TECHNICAL DATA

Supply voltage	220 / 240 V (-15... +10%) 50 Hz (40 - 60 Hz)
Fuse rating	max. 10 A rapid
Power consumption	approx. 10 VA
Max. current rating	4 A per terminal 6 A total
Permissible ambient temperature	-5° C to +60° C
Pressure or temperature sensor	Pt 100 resistance thermometer or FED pressure sensor
Feedback	100 W potentiometer on regulating device
Feedback signal strength Xp	0 to $\pm 5$ % of the regulating range
Sensitivity E	adjustable up to $\pm 0.2$ % of the final value
Zero-point adjustment Xo	adjustable up to $\pm 25$ ° C for a desired value of 100° C
Standard measurement ranges	50 - 180° C and 140 - 360° C 1, 4, 16 and 25 bar, depending on type of FED
Length of cable to sensor and remote potentiometer	max. 200 m, 1.5 mm <sup>2</sup> (without screening)
Mounting attitude	any
Weight including base	approx. 900 g

## ADJUSTING THE REGULATOR

### Initial adjustment of the potentiometers

Set sensitivity "E" to maximum (position 10), "Xo" and P-range "Xp" to 0. The potentiometer for setting the desired value, or respectively, the FED nominal value, should be adjusted to the minimum position.

### Switching on

After switching on the mains voltage, the "+" relay closes its contacts, which is indicated by the red lamp. The regulating device moves towards "higher output". When the system which is being regulated reaches the value set on the main potentiometer or, respectively, on the FED, the "+" relay opens, followed shortly afterwards by the "-" relay, which then closes its contacts. This is indicated by the green lamp. The regulating device then moves towards "lower output".

### Adjustment of the P-range "Xp"

The higher the "Xp" value, the greater the stability of regulation. Rapid changes in the actual or desired value are, however, corrected all the more slowly.

- After the desired value has been reached, the "Xp" potentiometer should be set to maximum (22).
- The behaviour of the regulating device or, respectively, the "+" and "-" indicators, should be observed. Corrections must be seen to take place step by step. If the regulating device alternates continuously between maximum and minimum, the connections on the feedback potentiometer should be reversed. (Reverse terminals 14 and 16)
- At intervals of approx. 5 min., reduce the "Xp" setting by one increment (e.g. from 22 to 21). With each adjustment, the regulating action becomes increasingly restless, until the regulating device begins to alternate continuously between the upper and lower limits.
- On reaching this limit of regulation stability, the "Xp" value should be set 2 – 3 increments higher.  
When these adjustments are being carried out, the desired value set on main potentiometer should not, as far as possible, be altered, even when considerable deviations from the desired value are observed.

### Sensitivity adjustment "E"

In order to achieve greater regulation accuracy, sensitivity "E" should be adjusted to suit the characteristics of the system.

If it is required that even a very minor change in the actual value should be corrected by the regulating device, "E" should then be set as high as possible (towards 10). Should the regulating device then begin to alternate continuously, sensitivity must be reduced by 1 - 2 increments.

Greatest possible regulating accuracy will be achieved when:

- P-range "Xp" is set as low as possible
- Sensitivity "E" is set as high as possible

### Adjustment of the zero point "Xo"

This adjustment allows the desired-value potentiometer to be calibrated to match the temperature being regulated. Deviations are caused by the resistance of the cabling to the temperature sensor.

When an FED pressure sensor is used, zero-point adjustment has no effect.

- The deviation from the desired value can be calculated by making use of a thermometer, pressure gauge or other measuring instrument which is temporarily fitted.
- The error can be corrected by adjusting "Xo", step-by-step, in the opposite direction to the deviation.

The adjustment of a regulator unit requires some patience, regardless of the make or model being used. It is pointless to constantly change the settings on the potentiometers. The regulating system should be allowed to operate for some time without further interference, but should be kept under observation during this period. Successful adjustment will be accomplished in a short time if our instructions are adhered to

## FAULT FINDING

In case of faulty operation, first check the following:

- Mains voltage 220 V, 50 Hz
- Tightness of terminals in the base, sensor, feedback and main potentiometers
- Wiring according to the wiring diagram
- Jumper wires in the base
- Feedback potentiometer

### Contacts of "+" or "-" relays remain closed

This can be caused by a break in the circuit or a short circuit in the cabling, at the resistance thermometer or at the remote main potentiometer.

Check using an ohmmeter (at room temperature).

- Between terminals 17 and 18: approx. 110 W
- Between terminals 12 and 13: the reading should be approx. 0.4 x temperature set

### Relays do not close, unit is extremely insensitive

Sensitivity set to minimum, jumper wires connected incorrectly or the unit is defective.

By employing the Satronic TM test base, all terminals can be tapped while the unit is in operation, using 4 mm banana-type plugs. The TM test base consists of a base unit and plug-in part, which are connected together by a multiple-core cable with a length of approx. 1.5 metres.

### PT 100 temperature Sensor

The PT 100 consists of a platinum measuring resistor encapsulated in a glass or steatite body. Its resistance values and tolerances are standardised in accordance with DIN 43760. The particular advantages of this measuring resistor are the reproducible temperature/resistance curve which remains stable over a period of many years, and its high accuracy.

There are a variety of versions available on the market. Satronic would be pleased, at any time, to suggest a version suitable for your requirements.

## Photo-Electric pressure Sensor FED 621

### INTRODUCTION

The photo-electric pressure sensor converts a varying pressure value into a reproducible, varying electrical resistance value. It is used to sense and transmit a pressure value to the UPR 770 regulator.

Depending on the pressure value detected by the sensor, a shielding vane allows more or less light to reach the photo resistors. The light source is provided by two built-in electric lamps (1 lamp is a back-up) which are powered directly by the measuring bridge voltage.

When setting the desired value, the photo resistors are moved in relation to the shielding vane and the light source.

### TECHNICAL DATA

For connection to	UPR 770 Regulator
Sensitivity	$\pm 0.2$ % of final value
P-range	$\pm 6$ % of final value
Adjustment range	20 - 100% of manometer final value
Permissible ambient temperature	0 - 50° C
Lamp type	E10 / 8041 D (Phillips)
Standard versions	FED 621-1 1 bar FED 621-4 4 bar FED 621-16 16 bar FED 621-25 25 bar Other pressure ranges available on request



### INSTALLATION

The pressure sensor should be mounted vertically, in a position where it is subjected to as little vibration as possible. Direct sunlight should be avoided.

To reduce the vibration transmitted to the pressure sensor during operation, a vibration absorbing device (spiral) should be fitted in the connecting pressure line.

An operating temperature of 50°C must not be exceeded. The sensor should therefore not be mounted directly on the heating system boiler.

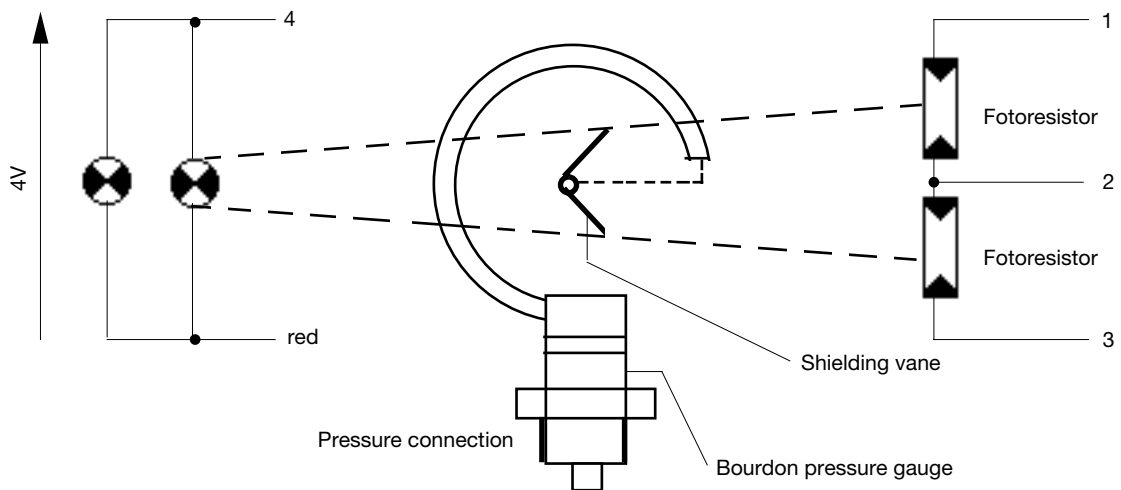

### REMOTE PRESSURE SENSOR

In the case of the remote pressure sensor, pressure variations are transferred to a mechanically coupled potentiometer. Rotation of the pointer spindle causes the potentiometer slider to move, resulting in a variation in the resistance. The UPR 770 compares this value with the value set on the main potentiometer. The main potentiometer and the mechanically coupled potentiometer both have the same inherent resistance.

When use is made of a remote pressure sensor, a 100 W, 0.5 W, 1% resistor should be wired in series with the potentiometer slider contact. The jumper wire in the UPR 770 base should not be cut.

### TECHNICAL DATA

Resistance range	100 W to 5 kW
Rating	$\geq 100$ mW

**WIRING DIAGRAMS**

Feedback potentiometer: Resistance 14... 15 decreases when regulating device (actuator) runs to end position.

**Wiring diagram for temperature regulation using PT 100**

Jumper wires in the base should not be cut.

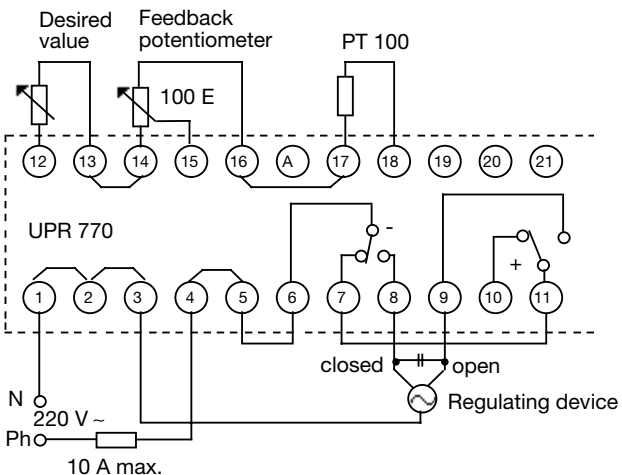

**Wiring diagram for pressure regulation using the FED 621**

Jumper wire in base cut.

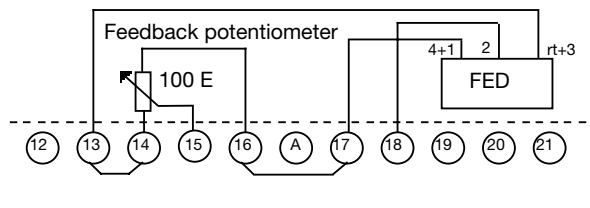

**Wiring diagram for regulation using remote pressure sensor**

Jumper wire in base not cut.

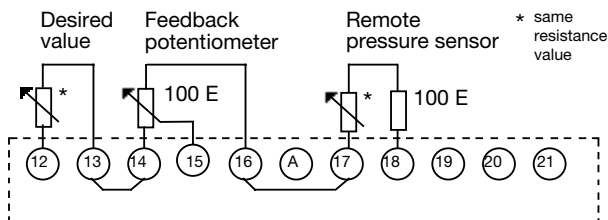

**Caution:**

All wiring should be checked before operating the system for the first time. Incorrect wiring could damage the regulator. Switch off or disconnect the power before plugging the unit into or removing it from its base.

**UPR 770 WITH BASE**

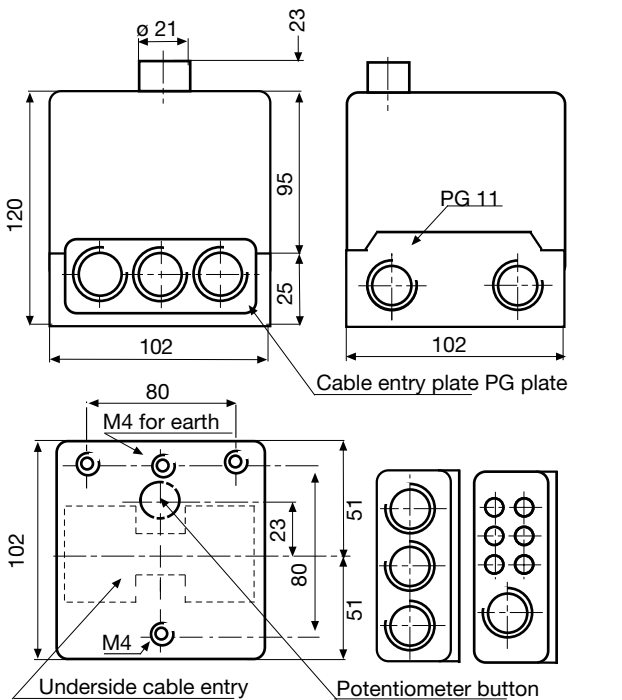

**DESIRED-VALUE POTENTIOMETER**

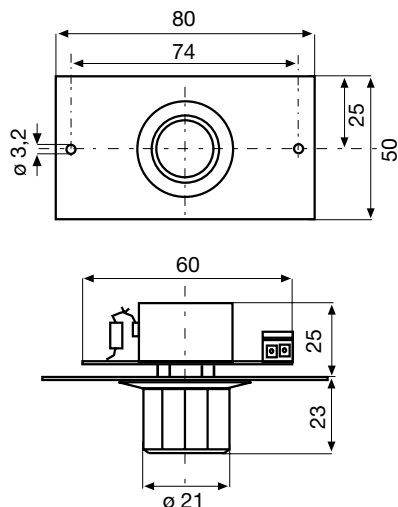

**ORDERING INFORMATION**

ITEM	DESIGNATION	ITEM NO.	ITEM	DESIGNATION	ITEM NO.
Regulator	UPR 770 regulator	18802	Pressure sensor	FED 621 1 bar	18223
Base	UPR 770 base	18132	optionally	FED 621 4 bar	18224
Insert plate	PG plate	70502	optionally	FED 621 16 bar	18226
optionally	Cable entry plate	70501	optionally	FED 621 25 bar	18227
Desired-value potentiometer	SWP 770 50 - 180° C	18733			
optionally	SWP 770 140 - 360° C	18734			
	SWP 770 0 - 100%	18735			

The above ordering information refers to the standard version. Special versions are also included in our product range.

Specifications subject to change without notice.

**UPR 770**



Satronic AG  
Brüelstrasse 7  
Postfach 324  
CH-8157 Dielsdorf

## Flame relay

**For semi automatic  
 oil- and gas power burners**

**Possible flame detectors:**

- Ionisation probe
- UV-cell
- Infrared flicker detector

### INTRODUCTION

The flame relay FFW 930 controls and monitors semi automatic oil- and power gas burners. It is also used together with an oil- or power gas burner control box for special, fully automatic control- and monitor functions.

### CONSTRUCTIONAL FEATURES

The flame amplifier circuit and a relay with 4 change-over contacts are housed and protected in a non-inflammable, non-transparent, plug-in type plastic case. A flame indicator bulb and the central locking screw are placed on top of the housing.

The wiring base is equipped with additional loop terminals and – together with the various possibilities for cable entry – enables an universal wiring.

### FUNCTION

Depending on the wiring, a semi or fully (only together with a burner control box) automatic control of a burner is possible.

As soon as a flame signal is detected, the built-in relay switches on, the relay contacts change over and activate the various burner components. Simultaneously, the flame indicator bulb on the top of the unit switches on.

### TECHNICAL DATA

Supply voltage	220 / 240 V (-15... +10%) 50 Hz (40 - 60 Hz)
Fuse rating	max. 10 A rapid, 6 A slow
Power consumption	5 VA
Max. current per output	4 A
Total	6 A
Amplifier sensitivity	1 µA
Min. current from UV tube or ionisation probe	5 µA
Flame detector cable	max. 20 m cable length
Flame detector	
- Ionisation probe	
- UV tube type	UVZ 780 red
- Infra-red flicker detector	IRD 1020
Weight incl. base	200 g
Mounting attitude	any
Permissible ambient temp.	-0°... +60° C



### APPLICATION TECHNOLOGY FEATURES

#### 1. Flame detection

The following types of flame detector can be employed:

- Ionisation electrode, where the mains supply provides a neutral earth connection. Suitable for gas burners (signal current from flame cannot be influenced by interference from ignition spark).
- UV sensor type UVZ 780 red, suitable for gas and combi burners.
- Infra-red flicker detector type IRD 1020 for all types of burner.

#### 2. Safety

The design/construction of the flame relay FFW 930 conforms to the present applicable European standards and regulations.

By use of a UV-cell or IRD flame detector, the flame sensor needs to be checked prior opening of the valves for their correct function (visually/manually or with a suitable wiring of the burner components).

#### 3. Mounting and Electrical Installation

At the base:

- 3 earth terminals, with an additional tag for the burner earth.
- 3 neutral terminals, with a fixed internal through connection to the neutral input, terminal 8.
- 2 separate slide-in plates and 2 fixed, threaded knock-outs (PG 11 thread) as well as 2 knock-outs underneath, facilitate wiring of the base.

General:

- Can be mounted in any position, insulated as per IP 44 standard (unaffected by water spray). The control box and detector probes should however not be subjected to excessive vibration.
- The applicable installation regulations must be observed during installation.

### SCHEMATIC CONNECTION DIAGRAM

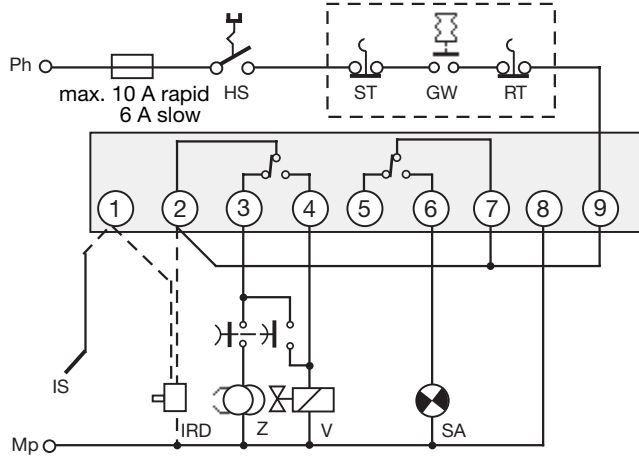
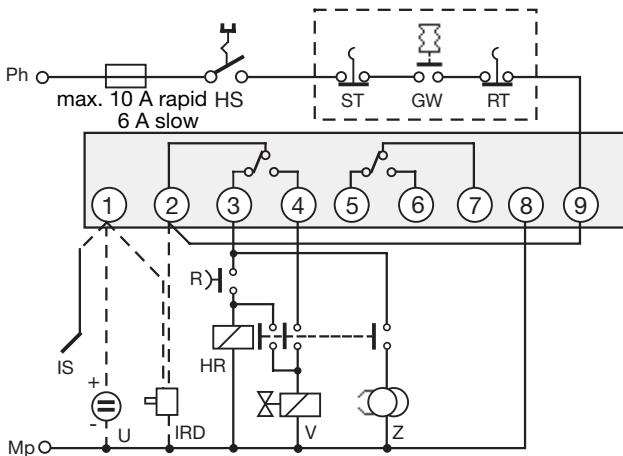

### IRD CONNECTION

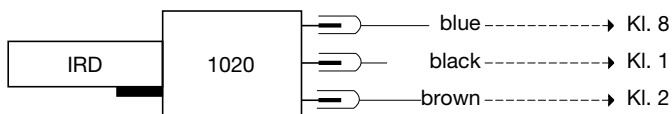

- |     |                     |    |                            |
|-----|---------------------|----|----------------------------|
| HS  | Mains switch        | V  | Ventil                     |
| ST  | Limit thermostat    | Z  | Ignition                   |
| GW  | Gas pressure switch | SA | External fault indication  |
| RT  | Control thermostat  | HR | Auxiliary relay            |
| IS  | Ionisation probe    | R  | Temporary switch for start |
| U   | UVZ 780 red         |    |                            |
| IRD | IRD 1020 or IRD 820 |    |                            |

### FFW 930 AND SOCKET

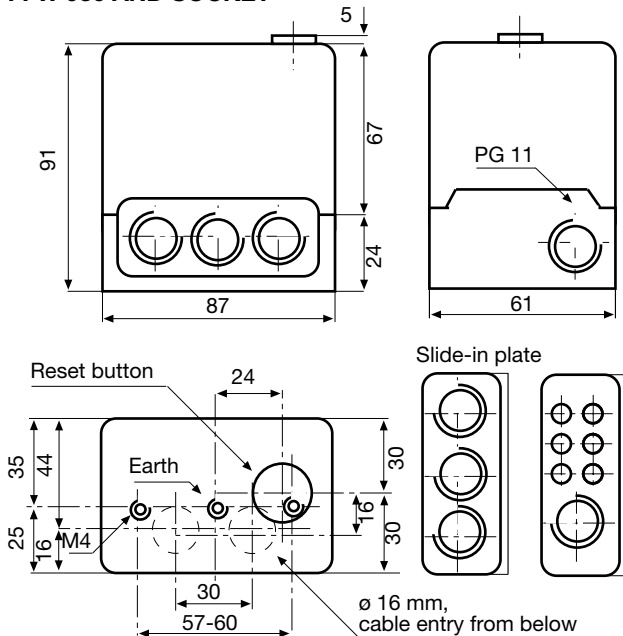

### CHECKING THE FLAMESIGNAL

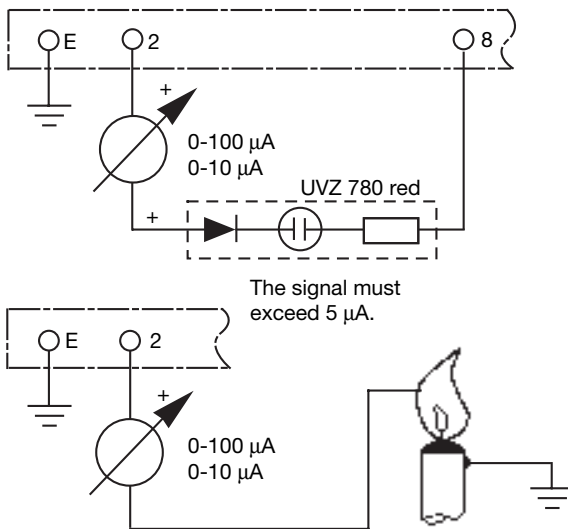

### ORDERING INFORMATION

ITEM	DESIGNATION	ITEM NO.
Flame relay	Flame relay FFW 930	06903
Socket	Wiring base 701 ABEN	70001
Slide-in-plate	PG-plate	70502
or	Cable terminal plate	70501

The above ordering information refers to the standard version. Special versions are also included in our product range.

Specifications subject to change without notice.

## FFW 930



Satronic AG  
Brüelstrasse 7  
Postfach 324  
CH-8157 Dielsdorf

## Remote- Multiple reset device

**Remote burner resetting for Satronic automatic burner controls for retro-fitting**

### INTRODUCTION

Quite often heating installations are located in inaccessible or poorly accessible places. If the burner develops a malfunction, then it is very difficult to reset it.

The solution: Remote resetting by means of FR 870 or MR 880

The remote reset device FR 870 or multiple reset device MR 880 can be retro-fitted to the following Satronic automatic burner controls:

Automatic oil burner controls	Series TF 800 TTO 872 TTO 876
Automatic gas burner controls	Series MMD Series TFI 800 Series MMI and MMG (as from manufacturing no. 704...)

The housing of the remote reset device is mounted on the automatic control like the pushbutton extension at the reset pushbutton, and the connection cable is connected according to the corresponding instructions.

### TYPES AVAILABLE

FR 870	Remote resetting of one burner with a Satronic automatic burner control.
MR 880	Remote resetting of several burners with Satronic automatic burner controls from one and the same remote reset pushbutton. When the reset pushbutton is actuated, only the burners manifesting a malfunction are reset, those burners working normally continue to operate without any interruption during this process.

### CONSTRUCTIONAL FEATURES

Built into a plastic housing is a lifting solenoid which is operated by direct current.

The current rectifying and a thermal overload protection are located on a printed circuit board and also accommodated in the housing.

The connection to the mains power supply is through a 20 cm long, 3-core cable which is tension-relieved.



### TECHNICAL DATA

Operating voltage	220 / 240 V (-15... +10%) 50 Hz (40 - 60 Hz)
Current demand	Maximum 300 mA
Waiting time between two actuations	approx. 10 sec
Weight	60 g
Mounting position	As required

The remote reset pushbutton (R) must be installed in such a manner, that the corresponding burner can be seen from the actuating position.

### DIMENSIONAL DRAWING

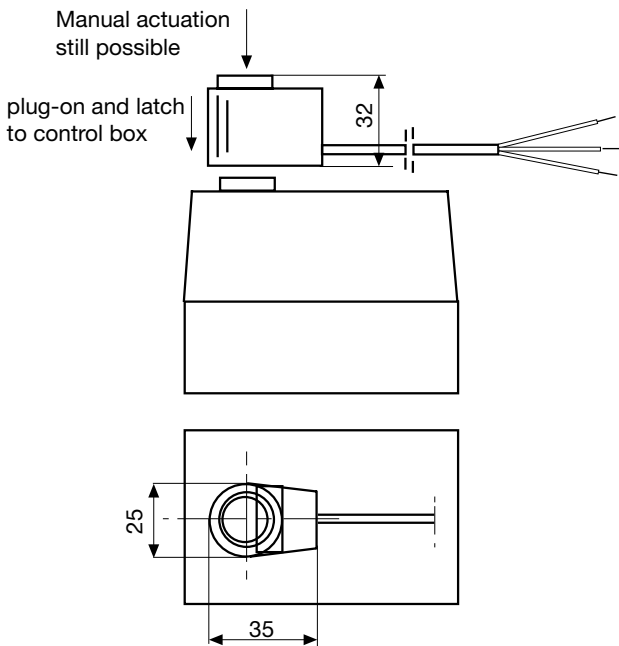

### CONNECTION DIAGRAM FR 870

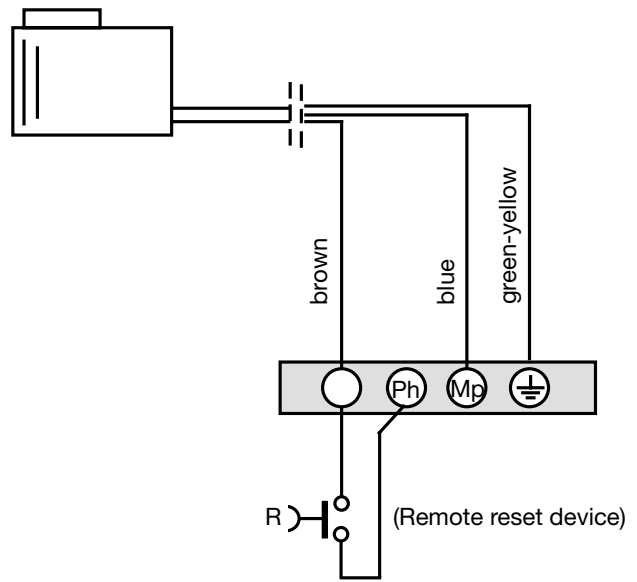

### SCHEMATIC DIAGRAM MR 880

Alarm output automatic burner control (e.g. terminal 7).

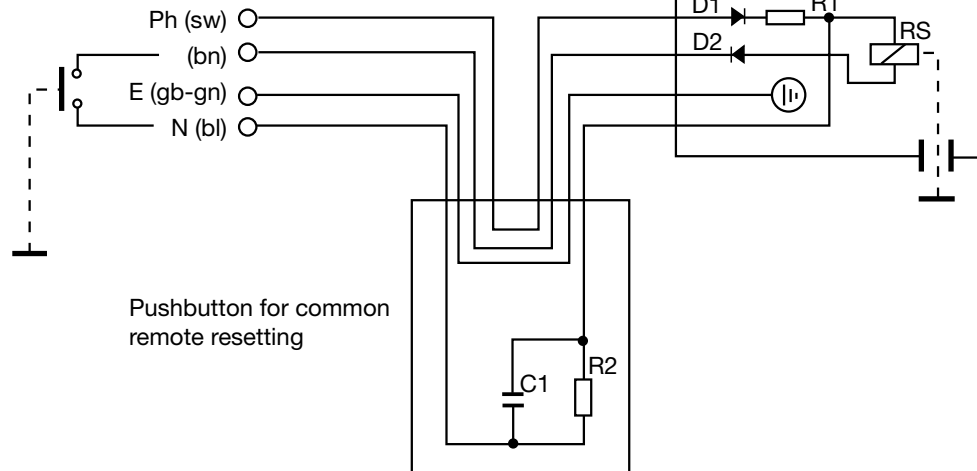

### ORDERING INFORMATION

ITEM	DESIGNATION	ITEM NO.
Remote reset device	FR 870	70700
Multiple remote reset device	MR 880	70710

The above ordering information refers to the standard version. Spezial versions are also included in our product range.

Specifications subject to change without notice.

**FR 870 / MR 880**

**satronic**  
A Honeywell Company

Satronic AG  
Brüelstrasse 7  
Postfach 324  
CH-8157 Dielsdorf

# Filter shut off valve for oil burner nozzles

**For oil burners  
 with an oil flow up to approximately 10 kg/h.**

## INTRODUCTION

The Satronic filter shut off valve effectively prevents the oil nozzle from dripping when the burner switches off. The start characteristics of the burner therefore will be considerably improved. The unburned hydrocarbons are significant below the limiting values which are stated in the EN 267. The nozzle shut off valve SFA 970 is available in different types and can be used with most of the existing types of oil nozzles.

## CONSTRUCTIONAL FEATURES

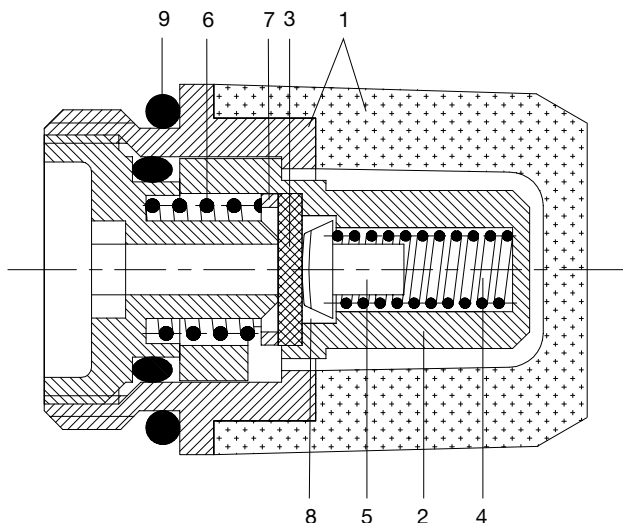

The filter shut off valve consists of rotation symmetrical components which are concentrically placed to the valve axis. The closed sinter filter with a brass thread (1) contains the valve housing with the valve seat (2) as well as the shut off component, the diaphragm (3).

Contained in the valve housing is the push spring (4) which presses the diaphragm through a push bolt (5) tight to the valve seat. The push spring (6) with a between ring (7) counterholds the diaphragm to ensure a smooth surface pressure against the diaphragm seat. Consequently a 100% sealing against the spring room (8) is guaranteed.

The O-Ring (9) prevents, that oil can flow through the connection between the nozzle and SFA 970 outside the shut off device.

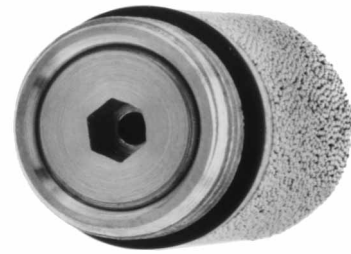

## TECNICAL DATA

Opening pressure	8 bar
Closing pressure	5 bar
Sinter filter grain 2	until 1 USG/h
Sinter filter grain 3	1-2.5 USG/h

**DESCRIPTION OF OPERATION**

The shut off device of the filter shut off valve is designed as a diaphragm. In order that it can lift from the valve seat against the power of the first spring, a determined over pressure, the opening pressure, must be established inside the inlet room. Until this opening, the pressure only acts at the outer part of the diaphragm. Up on reaching the necessary opening pressure, the diaphragm lifts from the valve seat. The oil flows in the outlet channel and gets into the nozzle.

After the valve opened, the oil pressure acts at the complete diaphragm surface. Consequently a lower over pressure is necessary to keep the valve open. The result ist an optimally atomized oil spray through the nozzle as soon as the valve opened.

If the oil pressure decreases below a defined pressure, the closing pressure, then the power of the push spring will be sufficient to close the valve through the push bolt and the diaphragm. The pressure loss of the filter shut off valve is almost negligible. Therefore it is not necessary to adapt the pump pressure.

**APPLICATIONS ENGINEERING FEATURES**

The Satronic filter shut off valve is available in different types to be used with the nozzles from Steinen, Danfoss, Fluidics, Delavan and Monarch. The existing sinter filter, which is screwed with the nozzle, simply need to be removed and be replaced with the filter shut off valve SFA 970. Which should be screwed with the nozzle by hand.

**SCALE DRAWING SFA 970**

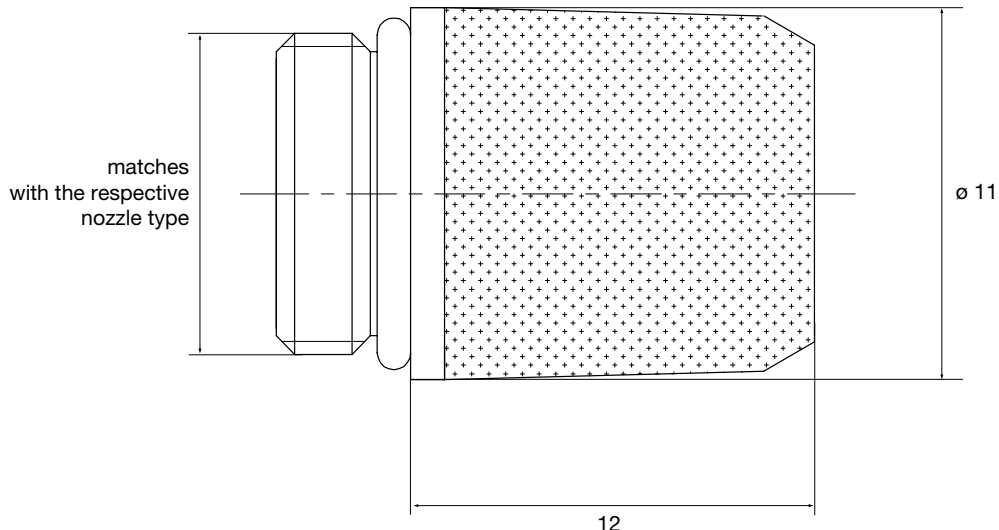

**ORDERING INFORMATION**

ITEM	DESIGNATION	ITEM NO.
Filter shut of valve for Delavan, Monarch	SFA 970 Grain 2	24100
Filter shut of valve for Delavan, Monarch	SFA 970 Grain 3	24101
Filter shut of valve for Steinen, Danfoss, Fluidics	SFA 970 Grain 2	24110
Filter shut of valve for Steinen, Danfoss, Fluidics	SFA 970 Grain 3	24111
Filter shut of valve for Danfoss	SFA 970 Grain 2	24120
Filter shut of valve for Danfoss	SFA 970 Grain 3	24121

The above ordering information refers to the standard version. Special versions are also included in our product range.

Specifications subject to change without notice.

**SFA 970**



Satronic AG  
 Brüelstrasse 7  
 Postfach 324  
 CH-8157 Dielsdorf

## Oil preheater electronically controlled

**For oil burners with a throughput capacity up to 6 kg/h**  
**Precise control of the oil output temperature**  
**Electronic control intergrated in the preheater**

### INTRODUCTION

On the electronically controlled oil preheater type SOVE 930, the oil output temperature is maintained at a constant level, independant of the oil input temperature, viscosity and supply voltage variations.

The fuel oil is preheated immediately before it enters the burner nozzle. This achieves a virtually constant viscosity for atomisation and leads to reliable ignition and good combustion.

### CONSTRUCTIONAL FEATURES

The basic component is a tube containing a sintered body, which by its nature has a very large surface area for transmitting the temperature to the oil. The heating power, per unit of surface area is correspondingly low, which prevents coking.

A heating element of 120 watts is wound round the tube and is protected by a solid brass jacket, secured against rotation. The oil is supplied through a central connection. Apart from the release thermostat, the heating element and the temperature sensor, all electrical and electronic components for the temperature control are located on a printed circuit board. It is mounted in a plastic housing together with the release thermostat, which is thermally connected to the shaft, and is protected against shock damage and the ingress of dirt.

Supply cable and preheater can be seperated by a plug connector. This permits easy installation and removal.



### TECHNICAL DATA

Operating voltage	220 / 240 V (-15... +10%) 50 Hz (40 - 60 Hz)
Release contact switching current	4 A permanent current (cos $\phi$ 0.6)
Heating power	max. 120 W
Oil flow throughput	up to approx. 6 kg/h
Permissible pressure	max. 25 bar
Oil volume	2 cm <sup>3</sup>
Oil temperature in the nozzle when released	45° C
Control temperature	max. 65° C
Control amplitude	less than 0.5° C
Switch gap of the release thermostat	14° C
Preheat time at 15° C input temperature	approx. 20 sec
Weight	106 g
Wrench size	
- jacket	SW 16
- oil inlet part	SW 13

## APPLICATIONS ENGINEERING FEATURES

The preheater type SOVE 930 can be connected to any automatic oil burner safety control box.

**A unit with a thermostat loop and/or overriding contact (interceptor circuit) is not necessary.**

The controlled temperature is held constant, independent from oil inlet temperature, flow capacity and mains voltage. 120 watts heating power enables the SOVE 930 to be used universally with burners having an oil throughput of up to 6 kg/h. The heat exchanger, with its large surface area, and the electronic control circuit prevent the oil from coking at very small throughputs and under burner fault conditions. The thermostat contact releases the burner to start. This contact breaks if the temperature drops below 40° C.

In case of an interruption of the oil supply – a so called zero throughput – the temperature for the heating element is limited to 80° C.

The central oil connection, the simple cylindrical shape of the preheater and the plug connector enable this unit to be fitted to any burner assembly. The print-connector is compatible with all available preheater-plugs.

The preheater is also available in an uncontrolled version, called **SOVU 930**.

## DESCRIPTION OF OPERATION

A specially designed electronic circuit controls the temperature of the preheater type SOVE 930. A PTC-element acts as a sensor. The heating element is switched on and off by an electronic switch.

At the start, the oil is heated up to the release temperature with a heating power of 120 watts. The contact of the release thermostat is then closed and the burner is able to start. After this the oil output temperature is controlled at a constant level. The electronic circuit also makes sure that this operating temperature does not drop.

## CONTROL CIRCUIT OF THE SOVE 930

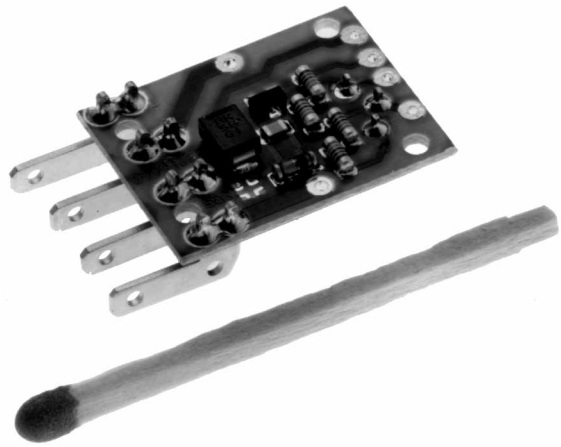

## COMMISSION AND MAINTENANCE

### Important notes

During assembly and wiring, the appropriate installation guidelines have to be fulfilled.

The chosen fuse rating must not, on any account, be higher than the value given in the technical data.

Failure to observe this instruction could, in the case of a short circuit, have serious consequences for the preheater or burner system.

### WIRING DIAGRAM SOVE 930

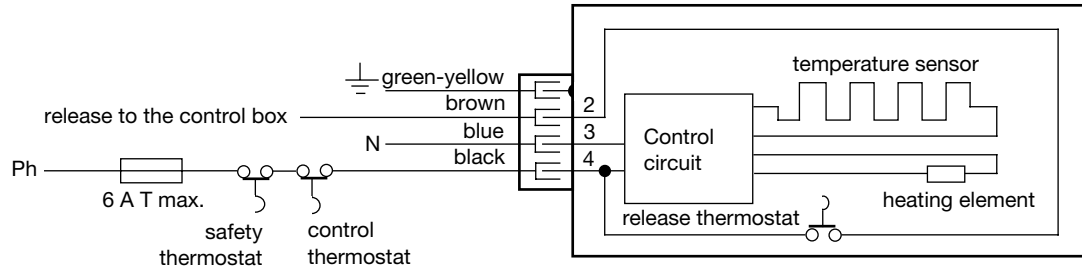

### STARTPROCESS SOVE 930 AT A THROUGHPUT OF 2.5 KG/H

Place of measurement: in the oil between shaft and nozzle filter – Test fluid: Shell Calibration fluid – Voltage: 230 V

temperature (° C)

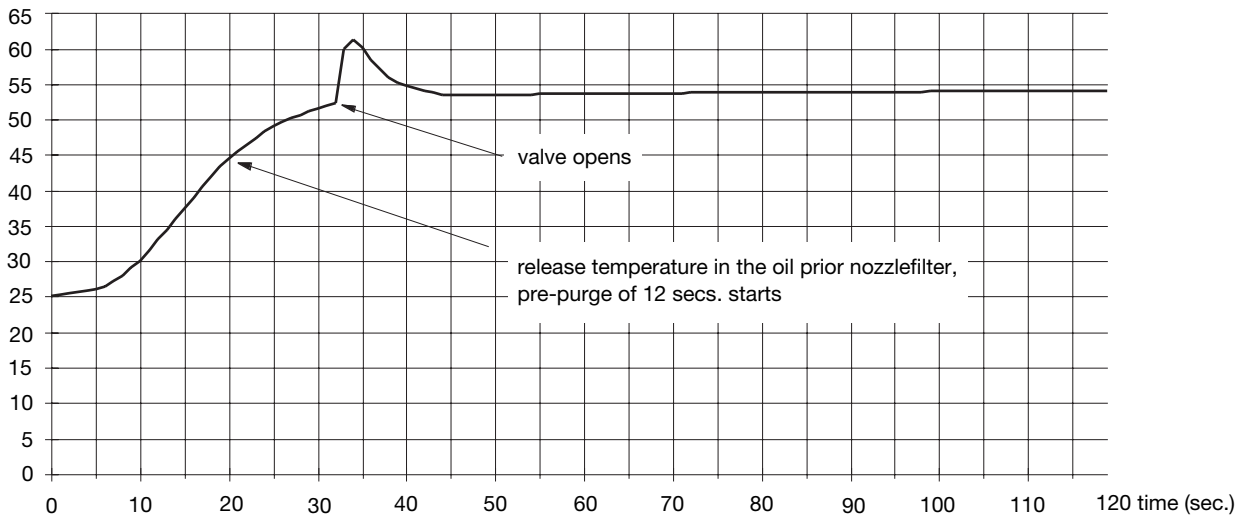

### SOVE 930, OIL OUTLET TEMPERATURE AS A FUNCTION OF THROUGHPUT AND POWER

Place of measurement: in the oil between shaft and nozzle filter – Test fluid: Shell Calibration fluid – Voltage: 230 V

temperature (° C)

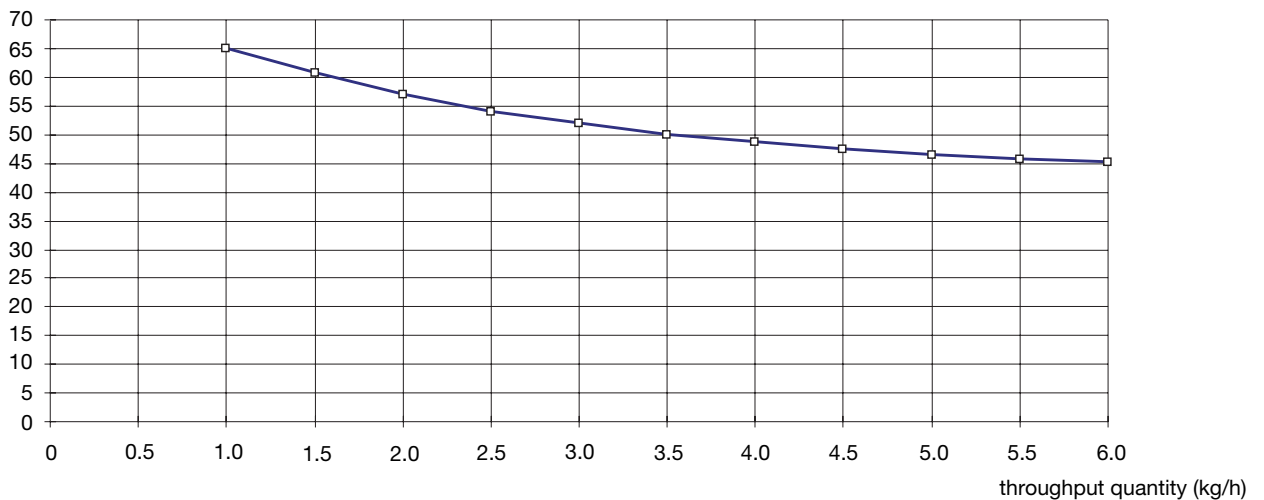

Variation of the voltage between 205 V and 255 V changes the temperature related to the throughput quantity only for max. ± 1° C.

**SECTIONAL DRAWING SOVE 930 (1:1)**

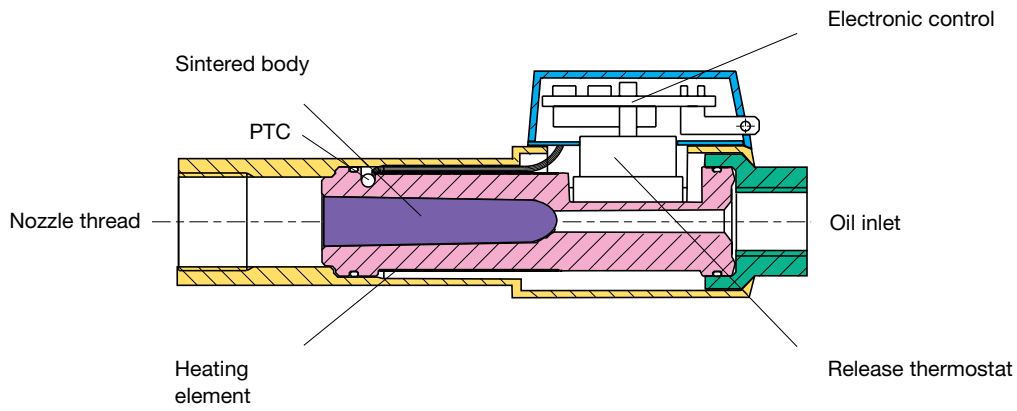

**SCALE DRAWING SOVE 930**

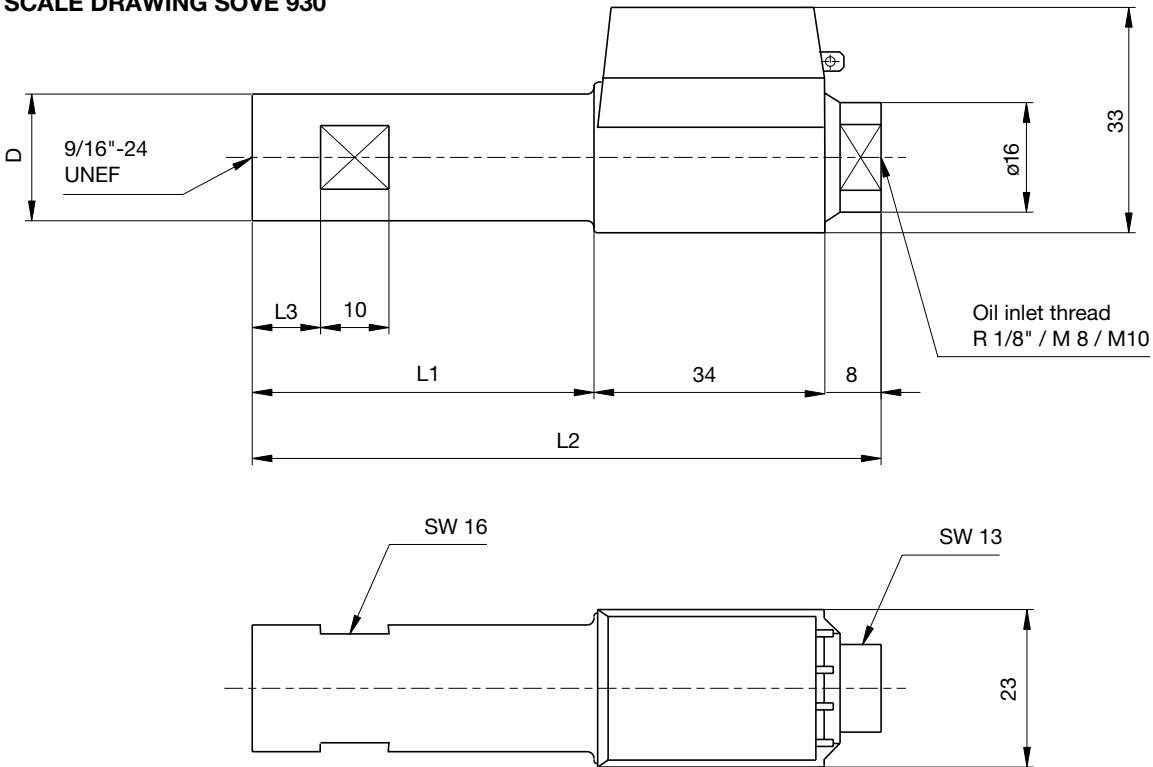

**Dimensions**

L1	L2	L3	D	Versions
50	92	10	18.5	SOVE 930 standard
90	132	20	18.5	SOVE 930 L

The dimensions L1 and D can also be customized according to customers drawings.

**ORDERING INFORMATION**

ITEM	DESIGNATION	ITEM NO.
oil preheater	preheater SOVE 930 standard	10100
Supply cable	preheater supply cable 4-wire, 400 mm	7244001

The above ordering information refers to the standard version. Special versions are also included in our product range.

Specifications subject to change without notice.

**SOVE 930**



Satronic AG  
 Brüelstrasse 7  
 Postfach 324  
 CH-8157 Dielsdorf

## Oil preheater uncontrolled

**For oil burners with a throughput capacity  
 from 1.5 to 6 kg/h  
 With a continuous heating capacity  
 of 35 or 55 watts**

### INTRODUCTION

Depending on the throughput and heating power of the SOVU 930, the oil outlet temperature is increased by 30... 50° C which increases the ignition capability of the burner considerably, and flame stabilisation is achieved.

### CONSTRUCTIONAL FEATURES

The basic component is a tube containing a sintered body, which by its nature has a very large surface area for transmitting the temperature to the oil. The heating power, per unit of surface area is correspondingly low, which prevents coking.

A heating element of 35 or 55 watts is wound round the tube and is protected by a solid brass jacket, secured against rotation. The oil is supplied through a central connection.

The release thermostat is thermally connected to the shaft and, together with the terminals for the heating element, is mounted in a plastic housing. This housing protects against shock damage and the ingress of dirt.

Supply cable and preheater can be separated by a plug connector. This permits easy installation and removal.



### TECHNICAL DATA

Operating voltage	220 / 240 V (-15... +10%) 50 Hz (40 - 60 Hz)
Release contact switching current	4 A permanent current (cos φ 0.6)
Heating power	55 / 35 W
Oil flow throughput	between 1.5 and ca. 6 kg/h
Permissible pressure	max. 25 bar
Oil volume	2 cm <sup>3</sup>
Preheat time at 15° C input temperature	35 / 55 sec.
Weight	105 g
Wrench size	
- jacket	SW 16
- oil inlet part	SW 13

## APPLICATIONS ENGINEERING FEATURES

To prevent switching off when not desired as a result of oil temperature fluctuations, the SOVU 930 preheater should always be operated with an automatic oil burner safety control having an overriding contact.

The burner safety control must switch off the preheater in the event of a shutdown caused by a fault.

The SOVU 930 preheater is a reliable and rugged design. The central oil connection, the cylindrical shape and the electrical supply with plug connector allow this unit to be fitted in any burner unit. The plug connector is fully compatible with all available connectors.

The **SOVE 930 electronically controlled preheater** is available for more demanding applications (providing increased heating power, oil outlet temperature independent of flow and inlet temperature; thermostat loop and overriding contact not necessary, max. temperature-limit at 80° C at 0-throughput).

The heating power of the oil preheater should be selected so that with the smallest possible throughput the outlet temperature corresponds to the desired demands according to the diagram shown below.

## DESCRIPTION OF OPERATION

The SOVU 930 preheater is an uncontrolled version with a heating element. The temperature of the oil is raised gradually by a heat exchanger with a large surface area. The design ensures a very good distribution of heat.

At the start, the oil gets heated by a heating power of 35 or 55 W until the release temperature has been reached. Then, the contact of the release thermostat closes and the burner will start. In operation, the oil outlet temperature depends mainly on the selected heating power, the throughput and the oil inlet temperature.

## COMMISSION AND MAINTENANCE

### Important notes

During assembly and wiring, the appropriate installation guidelines have to be fulfilled.

The chosen fuse rating must not, on any account, be higher than the valve given in the technical data.

Failure to observe this instruction could, in the case of a short circuit, have serious consequences for the preheater or burner system.

## WIRING DIAGRAM SOVU 930

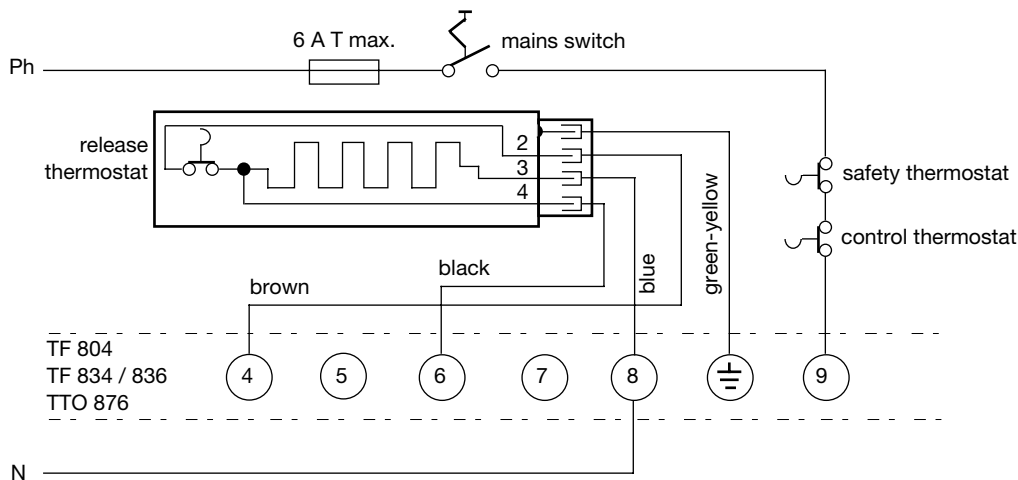

## STARTPROCESS SOVU 930 35 W AT A THROUGHPUT OF 2.5 KG/H

Place of measurement: in the oil between shaft and nozzle filter – Test fluid: Shell Calibration fluid – Voltage: 230 V

temperature (° C)

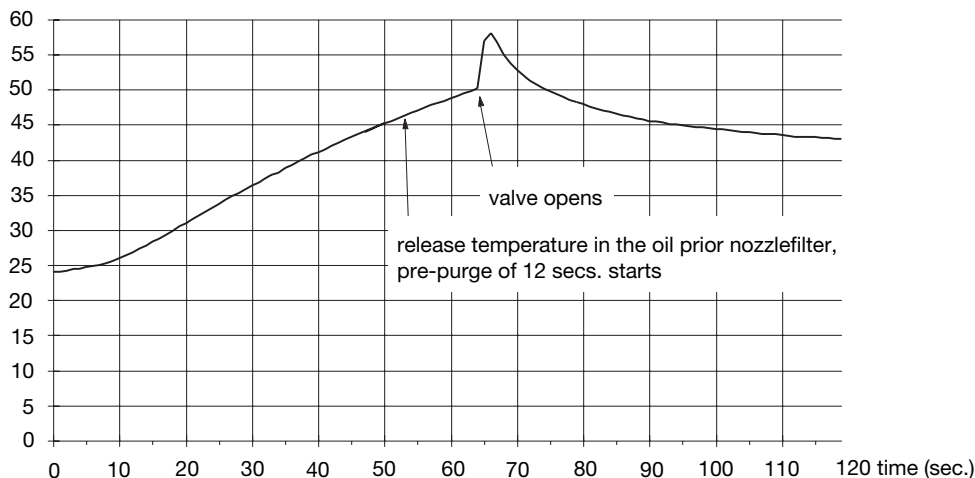

**SOVU 930 35 W, OIL OUTLET TEMPERATURE AS A FUNCTION OF THROUGHPUT AND POWER**

Place of measurement: in the oil between shaft and nozzle filter – Test fluid: Shell Calibration fluid – Voltage: 230 V

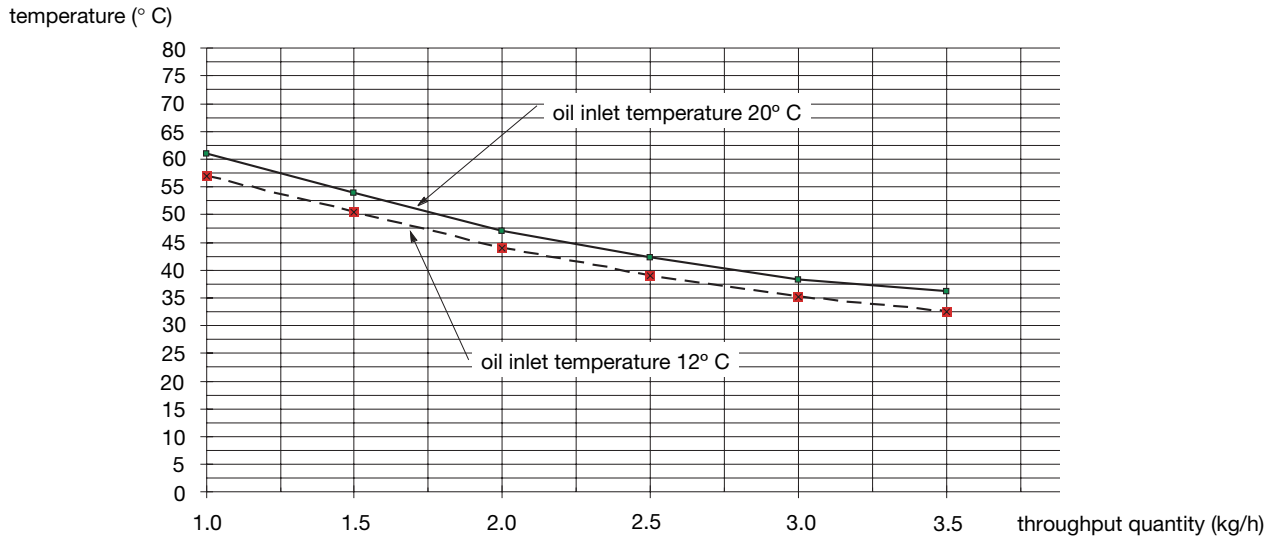

**STARTPROCESS SOVU 930 55 W AT A THROUGHPUT OF 2.5 KG/H**

Place of measurement: in the oil between shaft and nozzle filter – Test fluid: Shell Calibration fluid – Voltage: 230 V

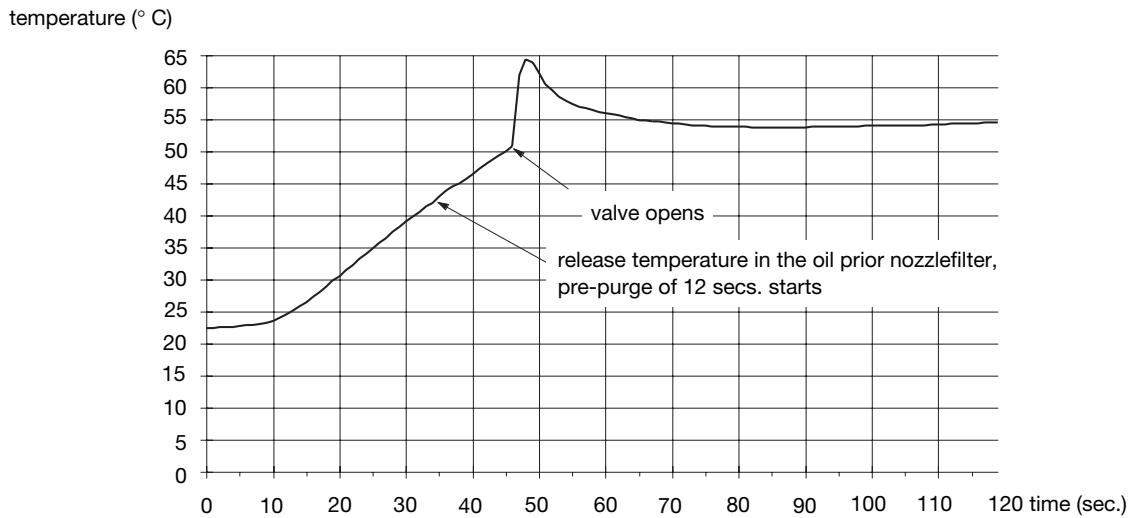

**SOVU 930 55 W, OIL OUTLET TEMPERATURE AS A FUNCTION OF THROUGHPUT AND POWER**

Place of measurement: in the oil between shaft and nozzle filter – Test fluid: Shell Calibration fluid – Voltage: 230 V

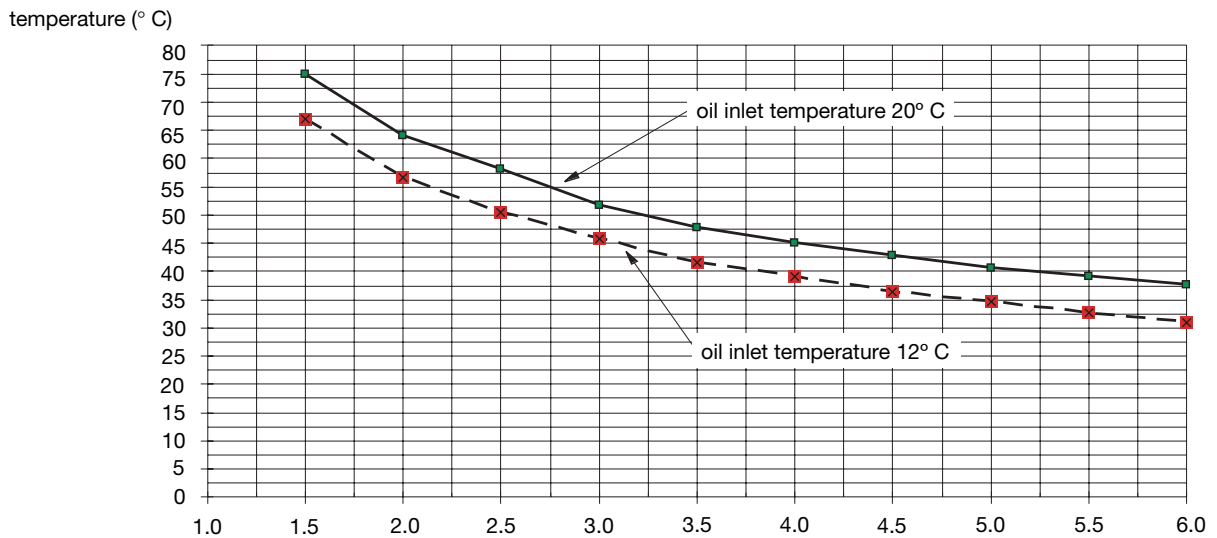

**SECTIONAL DRAWING SOVU 930 (1:1)**

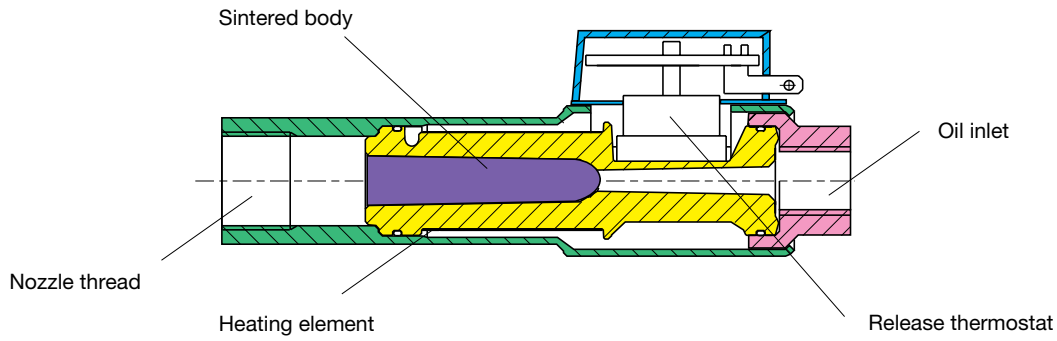

**SCALE DRAWING SOVU 930**

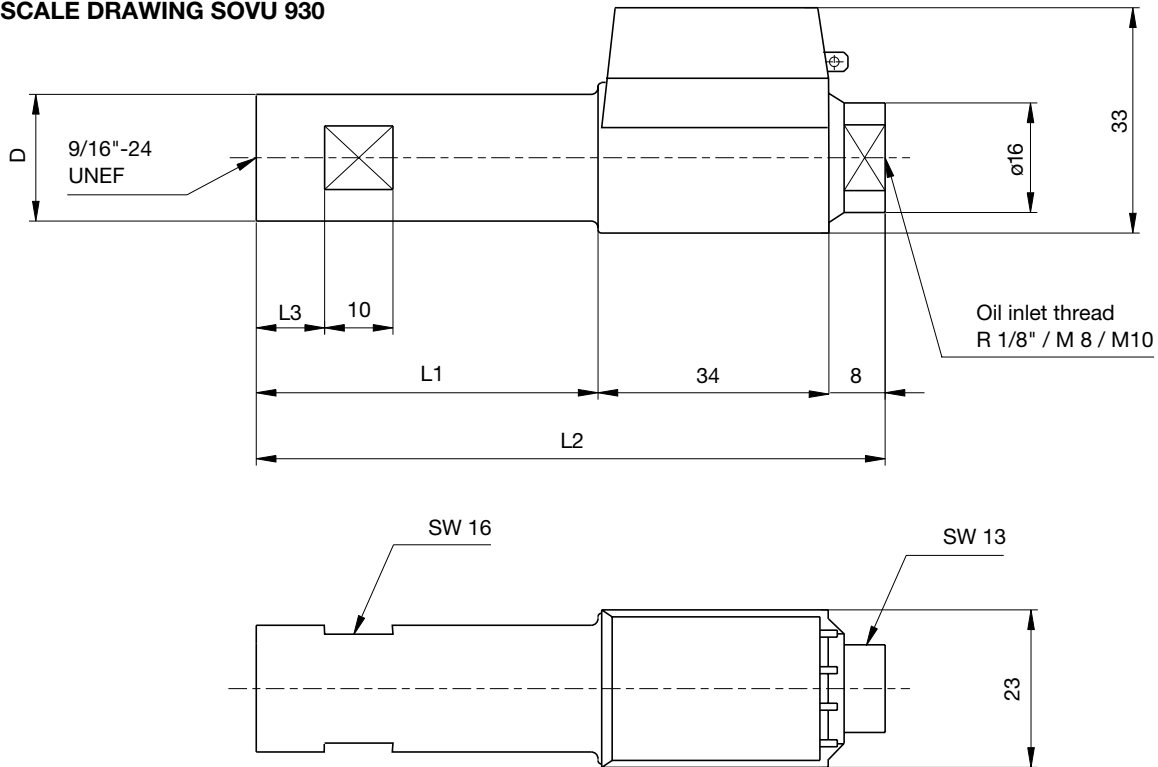

**Dimensions**

L1	L2	L3	D	Versions
50	92	10	18.5	SOVU 930 standard
90	132	20	18.5	SOVU 930 L

The dimensions L1 and D can also be customized according to customers drawings.

**ORDERING INFORMATION**

ITEM	DESIGNATION	ITEM NO.
oil preheater	preheater SOVU 930 55 W standard	10200
oil preheater	preheater SOVU 930 35 W standard	10300
Supply cable	preheater supply-cable 4-pol., 400 mm	7244001

The above ordering information refers to the standard version. Special versions are also included in our product range.

Specifications subject to change without notice.

**SOVU 930**



Satronic AG  
Brüelstrasse 7  
Postfach 324  
CH-8157 Dielsdorf

## High Frequency Ignition Transformers

**The ZT 8 is designed for application with small fully automatic oil burners, blown gas burners and atmospheric gas boilers**

### INTRODUCTION

The ignition transformer comprises a transistorised oscillator which produces a high frequency voltage. This voltage, at approximately 20 KHZ, is in turn applied to a conventional ironcored transformer which raises the voltage still further to that required for ignition purposes.

Depending upon the model number, the peak output voltage is between 10 KV and 14 KV, and the ignition spark produced is similar in characteristic to that of a conventional ignition transformer.

The oscillator and transformer sections are housed inside a tough plastic enclosure having high insulation properties, and forms an extremely neat and compact system.

General constructional details are in accordance with VDE regulations. Similarly some models are specifically approved for use in certain countries, e.g. ZT 812 approval by British Gas for use in the United Kingdom.

The dimensions and fixing arrangements allow it to be easily mounted in combination with the Satronic TF 800 and TFI 800 oil and gas burner safety controls series.

An input supply cable is provided, and depending upon the model, either one or two High Tension output cables are incorporated. The H.T. cables are insulated with superior quality Silicon and are available in various lengths, for precise details see specification table.

### INSTALLATION INSTRUCTIONS

Best results are achieved if installation is made in accordance with the following suggestions.

Observe correct wiring polarity, and where appropriate the earth wire must be connected, otherwise damage to the device may result.

H.T. cable runs to the ignition electrodes should be kept as short as possible, avoiding unnecessary bends or kinks with the insulation kept clear of any sharp edges.

The H.T. cable should not be run adjacent to other wiring. This is particularly important with regard to flame probe detector wiring on gas burners and gas boilers.

Correct setting of the spark gap between ignition electrodes or electrode and earth is very important to avoid trouble-free operation. Very low ambient temperature and low voltage conditions will give rise to problems if these settings are incorrect, see General Technical Data for recommended gap settings.

Avoid positioning the device where the ambient temperature exceeds 60° C.



### APPLICATION NOTES

Various models are available covering different supply voltages, e.g. 110 V, 230 V, 240 V and applications requiring either 1 or 2 H.T. outputs.

In general terms, oil burners will usually employ 2 ignition electrodes and therefore models ZT 801, ZT 802 etc. having 2 H.T. cable outputs should be used for this type of application. It should be noted that these types of ignition transformer are only suitable for small oil burners. To determine suitability, application tests should therefore be carried out to ensure that the volume of combustion air passing across the ignition spark, is not excessive to cause a reduction in spark temperature sufficient to prevent satisfactory ignition.

Gas burners usually employ only 1 ignition electrode, the ignition spark taking place between this and an earthed area of the burner. Models such as ZT 812, ZT 812B, ZT 815 etc with 1 H.T. output cable will therefore be suitable for this type of application.

Blown gas burners using ionisation or flame probe detection will often be affected by ignition spark interference to the flame signal current. The H.T. ignition spark can produce its own ionisation current, the polarity of which is random and therefore often in direct opposition to the flame signal current. If sufficient, the interference will swamp the flame signal with the result that nuisance shut-downs can occur. Certain models in the range therefore specially incorporate a power diode in the H.T. output stage. This effectively polarises the ignition ionisation current such that it is in the same direction as the flame signal current and nuisance shut-downs due to ignition interference are therefore avoided. For model details with output diode, see specification table.

The ZT 800 series high frequency ignition transformers are rated for intermittent operation only. Their use with burner safety controls which provide unduly long periods of ignition coupled with frequent on-off cycling should be avoided. This is less critical in the case of most gas burner applications where the ignition period provided by the burner safety control is usually of very short duration.

**GENERAL TECHNICAL DATA**

Model No	ZT 801	ZT 802	ZT 812	ZT 812B	ZT 815
Supply Voltage (+10%, -15%)	230 V	240 V	220/240 V	220/240 V	110 V/120 V
Supply Frequency (+ / -20%)	50 Hz	50 Hz	50 Hz	50 Hz	50 Hz
Power Consumption	50 VA	50 VA	50 VA	50 VA	50 VA
Secondary Voltage $\hat{u}$	2 x 7 kV	2 x 7 kV	10 kV	11,5 kV	8 kV
Secondary Current $I_k$	17 mA	16 mA	16 mA	19 mA	16 mA
Max. spark gap setting in mm	3-5 mm	3-5 mm	2-3 mm	2-4 mm	2-3 mm
Output Frequency	20 kHz				
Max. working ambient temperature	-10 bis +60° C				
Rating	Intermittent, 25% E.D.in 3 minutes				
Mounting attitude	Any				
Weight	approx. 230 gr.				
H.T. cable only	Silicon insulated, temperature rating 175° C				

Applicable to all types

Article No.	Model No.	Supply Voltage	H.T. Power	H.T. Cable			Supply cable L.mm
				L.mm	Ømm	No.	
12000	ZT 801	230 V	no	400	5	2	400
1200001	ZT 801	230 V	no	500	7	2	300
1200002	ZT 801	230 V	no	400	7	2	300
1200003	ZT 801	230 V	no	400	5	2	160
1200004	ZT 801	230 V	no	400	7	2	160
1200006	ZT 801	230 V	no	1000	7	2	300
1200007	ZT 801	230 V	no	400/500	7	2	180
12100	ZT 802	240 V	no	400	7	2	300
12400	ZT 815	110 V	yes	400	7	1	300
1240001	ZT 815	110V/120V	yes	1000	7	1	300
12600	ZT 812	220/240V	yes	400	7	1	300
1260001	ZT 812	220/240V	yes	1000	7	1	300
1260008	ZT 812	220/240V	yes	1500	7	1	300
1260002	ZT 812	220/240V	yes	1500	7	1	650
1260007	ZT 812 B	220/240V	no	400	7	1	180
1260004	ZT 812 B	220/240V	no	400	7	1	300
1260003	ZT 812 B	220/240V	no	1000	7	1	300
1260006	ZT 812 B	220/240V	no	1500	7	1	300

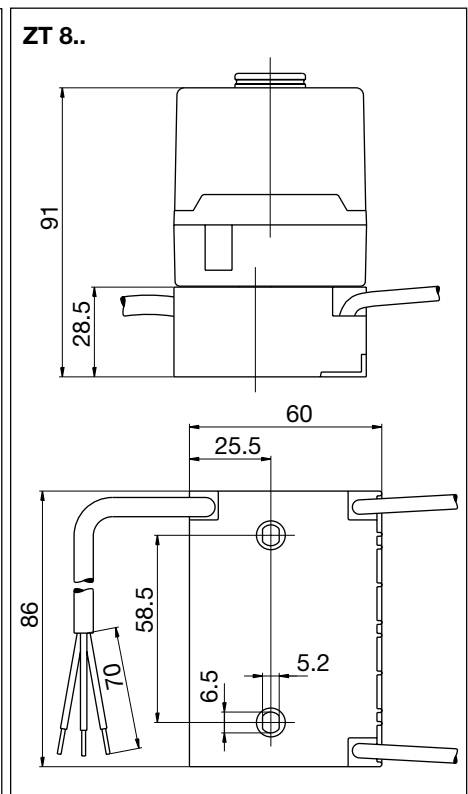

Specifications subject to changes without notice

**ZT 8..**



A Honeywell Company

Satronic AG  
Brüelstrasse 7  
Postfach 324  
CH-8157 Dielsdorf

# Ignition spark generator

**For atmospheric gas burners.  
 Mains and high-voltage cables with plug connectors.**

## INTRODUCTION

The ZT 870 ignition spark generator is particularly suitable for use with the TFI 812 control box, for fully automatic ignition of atmospheric gas burner systems.

## CONSTRUCTIONAL FEATURES

The transformer windings and the controlling electronics are contained in a temperature and impact resistant plastic housing, and sealed in a PU resin material which provides optimal protection from dampness and dirt.

One of the two mounting lugs is also designed to provide the earth/ground connection. Plug connectors for the mains and high voltage cables allow quick and simple installation.

## DESCRIPTION OF OPERATION

An electronic circuit produces approx. 50 sparks per second. The voltage of these sparks is increased by the transformer to approx. 16 kV.

The secondary voltage as well as the spark energy are independent of the mains frequency and mains voltage.

A reduction in the mains voltage simply causes the spark rate to drop, or respectively, to rise, should the mains voltage be too high.

Interference to ionisation flame detection is avoided by the very short spark interval and also by the stability of the ignition spark.

## INSTALLATION INSTRUCTIONS

The applicable installation regulations must be observed when mounting and wiring the unit.

The ignition cable should be kept as short as possible in order to avoid radio interference and a drop in performance.

The compact dimensions and simple installation procedure allow the ZT 870 ignition spark generator to be positioned close to the ignition electrode.



## TECHNICAL DATA

Supply voltage	220 / 240 V (-15... +10%) 50 Hz (40 - 60 Hz)
Connections:	
Live / neutral	Satronic 2-pin angled plug
Earth	Mounting lug
High voltage	ø 4 mm plug
Power consumption	17 mA
Switched on time	50% in 3 min.
Interference level	<N
Ignition voltage	16 kV (amplitude)
Ignition current	200 mA (amplitude)
Spark frequency	Approx. 50 Hz
Energy per spark	4 mJ
Spark gap	2... 5 mm
Ignition cable	Silicone, ø 7 mm Standard length, 30 cm
Insulation standard	IP 40
Permissible ambient temperature	-20° C... +60° C
Mounting attitude	any
Weight	220 g

The ZT 870 is also available for a supply voltage of 110/120 V.

**ZT 870 DIMENSIONS**

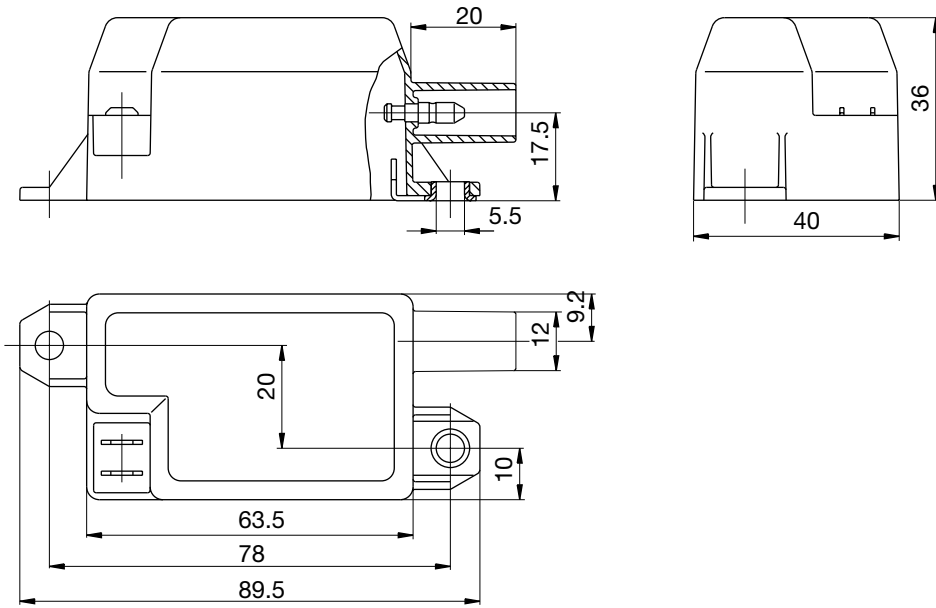

**ORDERING INFORMATION**

ITEM	DESIGNATION	ITEM NO.
Ignition transformer	ZT 870	13000
Mains cable	ZT 870 supply cord 0.3 m	7293001
Ignition cable	ZT 870 ignition cable 0.3 m	72730
Alternative ign. cable	ZT 870 ignition cable 1 m	72710

The above ordering information refers to the standard version.  
Special versions are also included in our product range.

Specifications subject to change without notice.

**ZT 870**



A Honeywell Company

Satronic AG  
Brüelstrasse 7  
Postfach 324  
CH-8157 Dielsdorf

## High frequency ignition unit

**For oil and gas dual burners of small to medium rating. With plug-in ignition and power supply cables, designed to fit beneath the burner safety control box.**

### INTRODUCTION

The ZT 900 high frequency ignition transformer is suitable for use with oil, gas and dual fuel burners of small to medium rating.

### CONSTRUCTIONAL FEATURES

A transistorised oscillator produces a high frequency voltage, which is then increased to 14 kV by a conventional iron-cored transformer. Despite the very compact dimensions of the ZT 900 ignition device, it has an outstanding performance in comparison to conventional stray field ignition transformers. The high frequency voltage produces a constant arc with high thermal energy and ideal ignition properties. The dimensions of the housing and fixing holes are such that it can be mounted underneath the burner control box wiring base.

The power supply for the ZT 900 is provided in the form of a 3 pin AMP type socket connection with a corresponding plug and cable supplied.

In order to meet all likely requirements, the ZT 900 is available in 2 versions:

- ZT 900 4.0 mm pin to suit standard ignition cable connectors, e.g. for pre-assembled "Teflon" H.T. cables.
- ZT 900 1.0 mm pin to suit 7.0 mm silicon H.T. cable in conjunction with the Satronic clip.

### INSTALLATION INSTRUCTIONS

The applicable regulations must be observed when mounting the device and carrying out the electrical connections. Particular attention must be given to method used to instal the H.T. cables. Avoid unnecessary lengths, sharp bends over hard edges, extremely high temperatures etc., any of which could give rise to reduced performance or possible problems.

For trouble-free operation, the correct spark gap at the ignition electrodes must be observed, supply voltage reductions and low ambient temperatures can give rise to problems if this is incorrect, see "Technical data" for recommended settings.

The positioning of the H.T. ignition cables with regard to TV and radio interference is also extremely important. The cables should be kept short, run as close together as possible and should not cross or be in contact with any other power cables or fittings.



### TECHNICAL DATA

Supply voltage	220 / 240 V (-15... +10%) 50 Hz (40 - 60 Hz)
Connections:	
Live / neutral / earth	3 AMP plug type terminals 6.30 x 0.8 mm
High tension	ø 4 mm pin or ø 1 mm pin
Primary current	0.4 A
Rating	Intermittent, 33 % E.D. in 3 minutes
Interference level	<N (VDE 0875)
Ignition voltage	2 x 7 kV
Secondary current	40 mA rms
Secondary frequency	20 kHz
Spark gap	2 - 3 mm
Ignition cable	plug-in type
Insulation standard	IP 40
Permissible ambient temperature	-10° C... +60° C
Mounting attitude	any
Weight	280 g

## ZT 900 DIMENSIONS

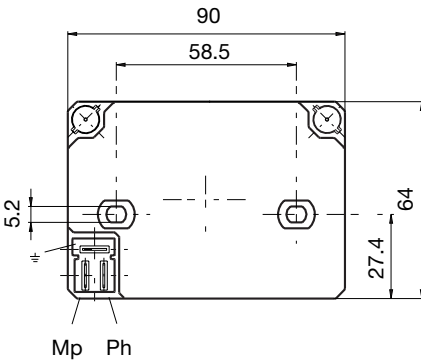
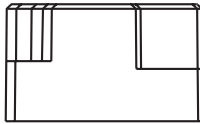
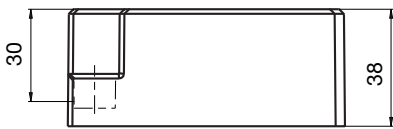

Version HF-pin  $\varnothing$  1 mm

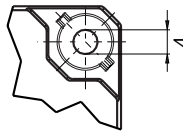

Version HF-pin  $\varnothing$  4 mm

## ZT 900 SUPPLY CORD PLUG DIMENSIONS

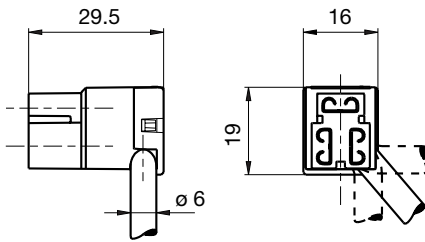

## HIGH VOLTAGE CABLE CLIP DIMENSIONS

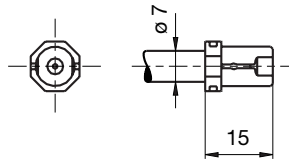

## ORDERING INFORMATION

ITEM	DESIGNATION	ITEM NO.
Ignition Unit	ZT 900 pin $\varnothing$ 1 mm	13101
or	ZT 900 pin $\varnothing$ 4 mm	13104
H.T. cable	H.T. cable ZT 900, 0.3 m	7283001
Ignition cable with clip, suitable for Item no. 13101	Silicon cable $\varnothing$ 7 mm, 0.4 m	7274009
Clip separat to silicon cable	High Voltage Cable Clip	74993

The above ordering information refers to the standard version.  
Special versions are also included in our product range.

Specifications subject to change without notice.

# ZT 900

**satronic**  
A Honeywell Company

Satronic AG  
Brüelstrasse 7  
Postfach 324  
CH-8157 Dielsdorf

## High frequency ignition unit

**For oil and gas dual burners of small to medium rating. With plug-in ignition and power supply cables, designed to fit beneath the burner safety control box.**

### INTRODUCTION

The ZT 930 high frequency ignition transformer is suitable for use with oil, gas and dual fuel burners of small to medium rating. The ZT 930 enables a big spark deformation on burners with a high fire-rating or high combustion-air velocity. In addition to this, it generates the lowest electromagnetic interferences of all known electronic ignition devices, which is especially important if the burner has to comply with EN 55014. The ZT 930 combines a low power consumption with a low inrush current. The power connector is compatible with the widely used 3-wire connector. A replacement with a plugable coil trafo is therefore possible without any problems.

### CONSTRUCTIONAL FEATURES

A transistorised oscillator produces a high frequency voltage, which is then increased to 14 kV by a conventional iron-cored transformer. Despite the very compact dimensions of the ZT 930 ignition device, it has an outstanding performance in comparison to conventional stray field ignition transformers. The high frequency voltage produces an interrupting arc with high thermal energy and ideal ignition properties. The dimensions of the housing and fixing holes are such that it can be mounted underneath the burner control box wiring base. The power supply for the ZT 930 is provided in the form of a 3 pin AMP type socket connection with a corresponding plug and cable supplied.

In order to meet all likely requirements, the ZT 930 is available in 2 versions:

- ZT 930 4.0 mm pin to suit standard ignition cable connectors, e.g. for pre-assembled "Teflon" H.T. cables.
- ZT 930 1.0 mm pin to suit 7.0 mm silicon H.T. cable in conjunction with the Satronic clip.

### INSTALLATION INSTRUCTIONS

The applicable regulations must be observed when mounting the device and carrying out the electrical connections. Particular attention must be given to method used to instal the H.T. cables. Avoid unnecessary lengths, sharp bends over hard edges, extremely high temperatures etc., any of which could give rise to reduced performance or possible problems. For trouble-free operation, the correct spark gap at the ignition electrodes must be observed, supply voltage reductions and low ambient temperatures can give rise to problems if this is incorrect, see "Technical data" for recommended settings. The positioning of the H.T. ignition cables with regard to TV and radio interference is also extremely important. The cables should be kept short, run as close together as possible and should not cross or be in contact with any other power cables or fittings.



### TECHNICAL DATA

Supply voltage	220 / 240 V (-15... +10%) 50 Hz (40 - 60 Hz)
Connections:	
Live / neutral / earth	3 AMP plug type terminals 6.30 x 0.8 mm
High tension	ø 4 mm pin or ø 1 mm pin
Primary current	0.25 A
Rating	Intermittent, 33 % E.D. in 3 minutes
Interference level	<N (VDE 0875)
Ignition voltage	2 x 7 kV
Secondary current	40 mA rms
Secondary frequency	20 kHz
Spark gap	3 - 5 mm
Ignition cable	plug-in type
Insulation standard	IP 40
Permissible ambient temperature	-10° C... +60° C
Mounting attitude	any
Weight	280 g

The ZT 930 is also available for a supply voltage of 110/120 V.

## ZT 930 DIMENSIONS

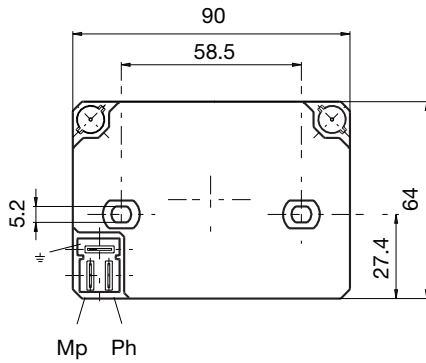
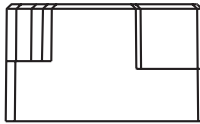
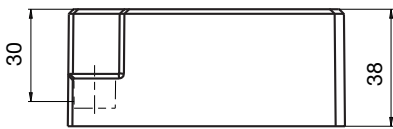

Version HF-pin  $\varnothing$  1 mm

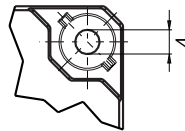

Version HF-pin  $\varnothing$  4 mm

## ZT 930 SUPPLY CORD PLUG DIMENSIONS

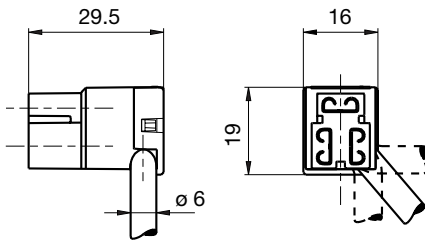

## HIGH VOLTAGE CABLE CLIP DIMENSIONS

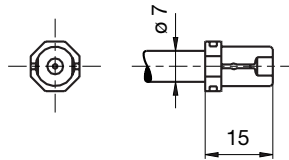

## ORDERING INFORMATION

ITEM	DESIGNATION	ITEM NO.
Ignition Unit	ZT 930 pin $\varnothing$ 1 mm	13121
or	ZT 930 pin $\varnothing$ 4 mm	13124
H.T. cable	H.T. cable ZT 900, 0.3 m	7283001
Ignition cable with clip, suitable for Item no. 13101	Silicon cable $\varnothing$ 7 mm, 0.4 m	7274009
Clip separat to silicon cable	High Voltage Cable Clip	74993

The above ordering information refers to the standard version.  
Special versions are also included in our product range.

Specifications subject to change without notice.

# ZT 930

**satronic**  
A Honeywell Company

Satronic AG  
Brüelstrasse 7  
Postfach 324  
CH-8157 Dielsdorf